



**Proposed Batoka Gorge Hydro-Electric Scheme
(Zambia and Zimbabwe) on the Zambezi River**

**VOLUME II Construction Environmental and
Social Management Plan (CESMP) for the Project
Area of Inundation, Staff Villages and Quarries
(V5.0)**

Zambezi River Authority (ZRA)

October 2021

www.erm.com

Zambezi River Authority

Proposed Batoka Gorge Hydro-Electric Scheme (Zambia and Zimbabwe) on the Zambezi River

VOLUME II Construction Environmental and Social Management Plan (CESMP) for the Project Area of Inundation, Staff Villages and Quarries (V5.0)

October 2021

Reference: 0239269

Prepared by: Environmental Resources Management Southern Africa (Pty) Ltd.
(ERM)

For and on behalf of
Environmental Resources Management

Approved by: Mike Everett

Signed: *Mike Everett*

Position: Partner

Date: October 2021

© Copyright 2019 by ERM Worldwide Group Ltd and /
or its affiliates ("ERM").

All rights reserved. No part of this work may be
reproduced or transmitted in any form,
or by any means, without the prior written permission of
ERM.

CONSULTANT DETAILS:

Environmental Resources Management Southern Africa (Pty) Ltd. (ERM)

Contact Person: Mr. Mike Everett

Postnet Suite 90, Private Bag X12, Tokai,
Cape Town, South Africa, 7966
Telephone: +27 (0) 21 681 5400
Fax: +27 (0) 21 686 0736

Black Crystal Consulting Private Limited

Contact Person: Ngoni Mandaba

1 Fairbairn Drive
Mt Pleasant
Harare
Zimbabwe
Box 9111 Harare
Telephone: (04) 334 361/ 307 581
Fax: (04) 307466

Felix Chisha K (independent consultant)

Zambia
felixchisha@yahoo.com

PROPONENT DETAILS:

Zambezi River Authority (ZRA),

Contact Person: Eng. Christopher Chisense, Project Director - Batoka HES

Zambezi River Authority
P. O. Box 30233, Lusaka, Zambia.
Telephone: +260 (211) 227 229
Fax: +260 211 227 498
Email: chisense@zaraho.org.zm

CONTENTS

ABBREVIATIONS AND ACRONYMS	I
EXECUTIVE SUMMARY	III
1 OVERVIEW	1
1.1 INTRODUCTION	1
1.2 ZAMBEZI RIVER AUTHORITY (ZRA) VISION, MISSION, VALUES AND POLICY	1
1.3 SITE LOCATION AND PROJECT DESCRIPTION	2
1.4 KEY COMPONENTS OF THE PROPOSED BGHES	3
1.5 PURPOSE AND OBJECTIVES OF THIS CESMP	6
1.6 STRUCTURE OF THIS CESMP	6
2 IMPLEMENTATION OF THIS CESMP	8
2.1 OVERVIEW	8
2.2 ENVIRONMENTAL AND SOCIAL MANAGEMENT SYSTEM	8
2.3 CHANGE MANAGEMENT	9
2.4 ROLES AND RESPONSIBILITIES	10
2.4.1 <i>The Developer</i>	10
2.4.2 <i>The Engineer</i>	13
2.4.3 <i>The Contractor</i>	13
2.4.4 <i>The Safety Health Environmental and Quality (SHEQ) Manager</i>	14
2.4.5 <i>ZRA Community Relations</i>	16
2.4.6 <i>Communication Channels</i>	16
2.4.7 <i>Environmental and Social Education and Awareness</i>	17
2.4.8 <i>Method Statements</i>	17
2.4.9 <i>Dispute Resolution</i>	18
2.5 TRAINING FOR IMPLEMENTATION OF THIS CESMP	18
3 ADMINISTRATIVE FRAMEWORK	20
3.1 ZAMBIAN LEGAL REQUIREMENTS AND STANDARDS APPLICABLE TO THIS ESMP	21
3.2 ZIMBABWEAN LEGAL REQUIREMENTS AND STANDARDS APPLICABLE TO THIS ESMP	30
3.3 INTERNATIONAL GUIDELINES AND STANDARDS APPLICABLE TO THIS ESMP	42
3.4 PROJECT STANDARDS	52
3.4.1 <i>Introduction</i>	52
3.4.2 <i>Water Quality</i>	52
3.4.3 <i>Air Quality</i>	55
3.4.4 <i>Noise</i>	56
4 CONSTRUCTION ESMP	58
4.1 SCOPE	58
4.2 ACTIVITIES TO BE UNDERTAKEN DURING THE CONSTRUCTION PHASE OF THE PROJECT	58

4.2.1	<i>Staff Township Development</i>	58
4.2.2	<i>Site Establishment for the Dam Wall</i>	59
4.2.3	<i>Powerhouses</i>	59
4.2.4	<i>River Diversion</i>	59
4.2.5	<i>Dam Wall Development</i>	59
4.2.6	<i>Dam Inundation</i>	59
4.2.7	<i>Permanent Staff Township Development</i>	59
4.2.8	<i>Unforeseen Events</i>	60
4.3	POTENTIAL ENVIRONMENTAL AND SOCIAL IMPACTS	60
4.4	METHOD STATEMENTS	61
4.4.1	<i>Other Method Statements</i>	63
4.5	DEVELOP EMERGENCY PREPAREDNESS PLAN	63
4.6	MANAGEMENT SPECIFICATIONS	64
4.7	TEMPORARY SITE CLOSURE	65
4.8	SITE CLEAN UP POST CONSTRUCTION	66
4.8.1	<i>Site Clean Up</i>	66
5	MONITORING AND AUDITING REQUIREMENTS	103
5.1	PHYSICAL MONITORING PLANS	104
5.1.1	<i>Air Quality</i>	104
5.1.2	<i>Noise and Vibration</i>	104
5.1.3	<i>Surface and Groundwater</i>	104
5.2	BIODIVERSITY MONITORING PROGRAMMES	104
5.2.1	<i>Taita Falcon Monitoring and Habitat Management</i>	104
5.2.2	<i>Rock Pratincole Monitoring Programme</i>	105
5.2.3	<i>Further Wildlife Monitoring</i>	105
5.2.4	<i>Monitoring and Management of Fisheries</i>	106
5.2.5	<i>Downstream Monitoring</i>	106
5.3	SOCIAL MONITORING PROGRAMMES	107
5.4	EMERGENCY PREPAREDNESS	108
5.5	MANAGEMENT OF NON-COMPLIANCE	108
5.6	MONITORING PLAN	109
5.7	AUDITING OF THE CONSTRUCTION ESMP	114
6	ENVIRONMENTAL AND SOCIAL MANAGEMENT AND MONITORING COST ESTIMATE	115
B1	METHOD STATEMENT TEMPLATE	1

LIST OF FIGURES

<i>Figure 1.1</i>	<i>Proposed Dam Site Location (1)</i>	4
<i>Figure 1.2</i>	<i>Proposed Dam Site Location (2)</i>	5
<i>Figure 2.1</i>	<i>Elements of an Environmental and Social Management System</i>	9
<i>Figure 2.2</i>	<i>Lines of Communication and Reporting</i>	10

LIST OF TABLES

<i>Table 3.2</i>	<i>Zimbabwean Legal Requirements and Standards Applicable to this ESMP</i>	30
------------------	--	----

<i>Table 3.3</i>	<i>International Guidelines and Standards Applicable to this ESMP</i>	<i>42</i>
<i>Table 3.4</i>	<i>Standards (Limits) for Effluent Discharge into the Natural Environment</i>	<i>52</i>
<i>Table 3.5</i>	<i>Table of Guideline Limits for Ambient Air at Source</i>	<i>55</i>
<i>Table 3.6</i>	<i>IFC/WHO Air Quality Guidelines at Source</i>	<i>56</i>
<i>Table 3.7</i>	<i>IFC Noise Level Guidelines</i>	<i>57</i>
<i>Table 4.1</i>	<i>Pre-construction and Construction Management Specifications</i>	<i>67</i>
<i>Table 5.1</i>	<i>Monitoring Plan to Ensure the Implementation and Effectiveness of the Construction Management Plan</i>	<i>110</i>
<i>Table.6.1</i>	<i>Costs of Social and Environmental Management</i>	<i>116</i>

LIST OF ANNEXURES

<i>Annex A - Grievance Redress Mechanism</i>
<i>Annex B - Method Statement Template</i>
<i>Annex C - Dam Safety Plan for the BGHES</i>
<i>Annex D - Water Quality Monitoring Parameters</i>

ABBREVIATIONS AND ACRONYMS

AoI	Area of Influence
BGHES	Batoka Gorge Hydro-Electric Scheme
BJVC	Batoka Joint Venture Consultants
CDP	Community Development Plan
CESMP	Construction Environmental and Social Management Plan
DATF	District AIDS Task Forces
E&S	Environmental and Social
EA	Environmental Assessment
EHS	Environment Health and Safety
EIA	Environmental Impact Assessment (generic term)
EMA	Zimbabwean Environmental Management Agency
EMP	Environmental Management Plan (generic term)
EPPCA	Environmental Protection and Pollution Control Act
ERM	Environmental Resources Management Southern Africa (Pty) Ltd.
ESIA	Environmental and Social Impact Assessment (as applied in this document)
ESMP	Environmental and Social Management Plan (as applied in this document)
ESMS	Environmental and Social Management System
ESS	Environmental and Social Safeguards
GPS	Global Positioning System
GWh	Gigawatt Hour
HIV / AIDS	Human Immunodeficiency Virus / Acquired Immune Deficiency Syndrome
ICMM	International Council of Mining and Metals
IFC	International Finance Corporation
IUCN	International Union for the Conservation of Nature
Km	Kilometre
L&FS	Life & Fire Safety
LED	Light Emitting Diode
LRP	Livelihood Restoration Plan
MSDS	Material Safety Data Sheet
MW	Megawatts
NGOs	Non-Governmental Organisations
NHCC	National Heritage Conservation Commission
NMMZ	National Museums and Monuments of Zimbabwe
NSR	Noise Sensitive Receptors
OESMP	Operation Environmental and Social Management Plan
OHS	Occupational Health and Safety
OP	Operational Procedure
PIIM	Project Induced In-Mitigation
PM	Particulate Matter
PPE	Personal Protective Equipment

PS	Performance Standard
RAP	Resettlement Action Plan
SASS5	South African Scoring System version 5
SEP	Stakeholder Engagement Plan
SHEQ	Safety, Health, Environment and Quality
SME	Small and Medium Enterprise
SP	Studio Pietrangeli Consulting Engineers
SPV	Special Purpose Vehicle
STI	Sexually Transmitted Infection
TB	Tuberculosis
UV	Ultraviolet
WHO	World Health Organisation
ZAMCOM	Zambezi Watercourse Commission
ZEMA	Zambia Environmental Management Agency
ZESA	Zimbabwe Electricity Supply Authority
ZESCO	ZESCO Limited
ZFC	Zimbabwe Falcon Club
ZPWMA	Zimbabwe Parks and Wildlife Management Authority
ZRA	Zambezi River Authority

EXECUTIVE SUMMARY

This report represents the Construction Environmental and Social Management Plan (CESMP) for the proposed Batoka Gorge Hydro-Electric Scheme (hereafter referred to as 'the BGHES' or the 'proposed Project'). More specifically, this plan presents the CESMP associated with the following Project components:

- Dam wall and impoundment, including a spillway;
- Surface power houses, one on each side of the river; and
- Project townships (in both Zambia and Zimbabwe) and other ancillary infrastructure (such as quarries, spoils area and batching areas).

Separate CESMPs have been compiled for 1) Access Roads in Zambia and Zimbabwe; and 2) Transmission Lines in Zambia and Zimbabwe. For a holistic understanding of Project environmental and social management commitments for during the construction phase, this CESMP should be considered in conjunction with the remaining Project CESMPs.

In addition to the CESMPs, an Operational ESMP (OESMP) has been developed, and provides measures for holistic environmental and social management, monitoring and reporting for all Project components (i.e. - the dam wall and impoundment, including spillway; surface power houses; Project townships; Access Roads and Transmission Lines) during the operational phase of the Project.

This CESMP provides for environmental and social management, monitoring and reporting for the pre-construction and construction phases of the Project. Environmental and social management and monitoring for the ongoing operational phase is included in a separate document.

The development of this CESMP has been guided by the overall ZRA vision, mission, values and social corporate policy; the World Bank Group Environmental and Social Safeguard Policies; International Finance Corporation (IFC) Performance Standards; International Finance Corporation (IFC) Environmental, Health and Safety (EHS) Guidelines; and African Development Bank Group's Integrated Safeguard System and Operational Safeguards.

This CESMP is reasonable and achievable in the local context (i.e. - it does not commit the Project to measures that are not achievable / possible in Zambia and Zimbabwe). It consists of the set of management, mitigation, and monitoring measures to be taken during implementation of Project activities, so as to eliminate adverse environmental and social impacts, offset them, or reduce them to acceptable levels, and provides measures to enhance or realise positive impacts. The CESMP details the specific actions for implementation of the agreed controls and mitigation measures as set out in the ESIA. It also includes responsibilities, timings, monitoring measures and clearly sets out an audit and review program. A main aim of the audit and review program is to facilitate compliance (e.g. by Contractors) with the agreed commitments and any permit conditions.

This CESMP includes management measures to mitigate impacts to an as low as reasonably practicable (ALARP) level for the following BGHES Project impacts:

Biophysical Impacts

- Impacts on air quality (elevations of airborne dust and particulate matter, PM₁₀ and PM_{2.5})
- Impacts on noise (noise emissions from Project construction activities)
- Impacts to water and soil resources as a result of construction pollution.
- Impacts associated with habitat loss and degradation
- Impacts to fauna
- Impacts associated with invasive alien plants
- Direct loss of critical habitat through filling of the reservoir and development infrastructure
- Habitat degradation resulting from altered flow regimes

Social Impacts

- Impacts associated with displacement (economic displacement of land-based livelihoods, fishing activities and downstream river users).
- Social benefits resulting from local employment opportunities, local procurement of goods and services and opportunities for community development.
- Impacts associated with unmet expectations.
- Impacts related to in-migration.
- Health and safety impacts (increased incidence of communicable diseases; increased incidence of malaria and other vector borne diseases; increased risk of traffic accidents; disturbance due to dust and noise; impact to community security; and worker health and safety)
- Changes to socio-cultural heritage and heritage resources due to destruction or disturbance to sites of heritage value and impacts to living cultural heritage.

This CESMP is a dynamic document implying that information gained during pre-construction, site establishment and the construction works and monitoring on the site could lead to changes in this CESMP. This CESMP has been compiled prior to the implementation of any activities on site and thus falls within the Planning phase of the Project. Further stages of management including doing, checking and acting are required for the implementation of an effective Environmental and Social Management System (ESMS). The ESMS entails a methodological approach to managing environmental and social risks and impacts in a structured way on an ongoing basis.

The ZRA is ultimately responsible for adherence to the management measures detailed in this CESMP, all conditions of approval of the Project and/or any aspect thereof by any authority.

This report represents the Construction Environmental and Social Management Plan (CESMP) for the proposed Batoka Gorge Hydro-Electric Scheme (hereafter referred to as 'the BGHES' or the 'proposed Project'). More specifically, this plan presents the CESMP associated with the following Project components:

- Dam wall and impoundment, including a spillway;
- Surface power houses, one on each side of the river; and
- Project townships (in both Zambia and Zimbabwe) and other ancillary infrastructure (such as quarries, spoils area and batching areas).

Separate CESMPs have been compiled for 1) Access Roads in Zambia and Zimbabwe; and 2) Transmission Lines in Zambia and Zimbabwe. For a holistic understanding of Project environmental and social management commitments for during the construction phase, this CESMP should be considered in conjunction with the remaining Project CESMPs.

In addition to the CESMPs, an Operational ESMP (OESMP) has been developed, and provides measures for holistic environmental and social management, monitoring and reporting for all Project components (i.e. – the dam wall and impoundment, including spillway; surface power houses; Project townships; Access Roads and Transmission Lines) during the operational phase of the Project.

This CESMP provides for environmental and social management, monitoring and reporting for the pre-construction and construction phases of the Project. Environmental and social management and monitoring for the ongoing operational phase is included in a separate document. The decommissioning of the BGHES is not included in this CESMP, as it is assumed that it will be drafted in accordance with existing legislation at the time of decommissioning.

ZAMBEZI RIVER AUTHORITY (ZRA) VISION, MISSION, VALUES AND POLICY

The development of this CESMP has been guided by the overall ZRA vision, mission, values and social corporate policy (refer to the boxes below). These are high-level corporate statements of intent and establish the principles to be followed in the management of environmental and social issues. The ZRA's vision, mission, values and social corporate policy therefore constitute the framework against which all related activities should be judged.

ZRA VISION, MISSION, AND VALUES

Vision – to be a dynamic and vibrant organisation, inspired by the passion to harness and manage the Zambezi waters for socio-economic development.

Mission – the ZRA commits themselves to satisfying all stakeholders through purposefully and sustainably exploiting the natural advantages offered by the Zambezi River.

Values – fairness, transparency, integrity, respect, health and safety and professionalism.

ZRA CORPORATE SOCIAL RESPONSIBILITY

As part of its Corporate Social Responsibility, ZRA has a social contract with the society in which it is operating. As a corporate citizen, ZRA defines this social contract by giving back to the community in which it operates and resides. As an institution, the ZRA believes that a satisfied human resource translates into multiplied productivity. The Authority has therefore a policy to integrate social and environmental concerns in its business operations and also in its interaction with the stakeholders (both internal and external) and on a voluntary basis. As such, the Authority is cognizant of its stakeholders' welfare through enhanced health, social and economic programmes which benefit all stakeholders.

The CESMP supports the commitments made by the ZRA.

1.3

SITE LOCATION AND PROJECT DESCRIPTION

The proposed BGHES is to be located at 17° 55' 38.55" S and 26° 6' 28.38" E ⁽¹⁾, in the central portion of the Zambezi River Basin, and will extend across the international boundary between Zambia and Zimbabwe. It will be situated upstream of the existing Kariba Dam hydroelectric scheme on the Zambezi River and approximately 47 km downstream of the Victoria Falls (see *Figure 1.1* and *Figure 1.2*).

This proposed bilateral hydropower project between Zambia and Zimbabwe includes the construction of a proposed 175 metres (m) high gravity arch dam that would provide a total capacity of 2,400 megawatts (MW) (to be shared equally between Zambia and Zimbabwe), and annual energy production of 10,215 Gigawatt hours per year (GWh/y).

In Zambia, the proposed BGHES falls within the Southern Province and in the districts of Kazungula, Zimba, Kalomo and Choma. Kazungula District, and in particular the ward of Mukuni, which falls in the Katombola Constituency and is under the jurisdiction of Chief Mukuni, will be most directly affected due to the placement of the dam infrastructure, access roads and staff township. The proposed transmission line alignment impacts on Kazungula District, as well as Zimba District, (namely Zimba ward), which is under the jurisdiction of Chief Sipatunyana, Kalomo District (especially Chawila ward), also under Chief Sipatunya and Choma District (in the ward of Singani). In Choma, it is Chief Singani who holds influence in the area of interest. The Area of Influence (AoI) also covers Livingstone District, as impacts are also likely to be experienced here.

In Zimbabwe, the proposed scheme falls within the province of Matabeleland North and in the Hwange District. It includes the wards of Matetsi, Chidobe,

(1) More accurate coordinates (in ITRF2008 Geographic) are provided by SP (2015) for the proposed site on both the Zambian and Zimbabwean banks of the river.

UTM Coordinates are 8017623.076 (Y) and 405516.5006 (X)

Katchecheti, Nemanhanga, Mbizha, Jambezi, Sidinda, Mashala and Chinkandukubi. The affected chiefdoms are Hwange, Mvutu and Shana. The proposed dam site is provided in *Figure 1.1*, (which is based on the map of the Surveyor-General, Zimbabwe Rhodesia, Batoka Gorge 1726 C3, Edition 2, Scale 1:50 000) and *Figure 1.2*.

1.4 KEY COMPONENTS OF THE PROPOSED BGHES

The proposed BGHES includes the following key components:

- Dam wall and impoundment, including a spillway;
- Surface power houses, one on each side of the river;
- Transmission lines in Zambia and Zimbabwe;
- Access roads in Zambia and Zimbabwe; and
- Project townships (in both Zambia and Zimbabwe) and other ancillary infrastructure (such as quarries, spoils area and batching areas).

These components are based on the dam design that was proposed in the 1993 Batoka Gorge HES Feasibility Study (BJCV, 1993) and the updated design described in the October 2018 Phase II Option Assessment Report (Rev. F), and subsequent October 2019 Phase III Feasibility Report (Rev. D) developed by SP for the BGHES Project.

Figure 1.1 Proposed Dam Site Location (1)

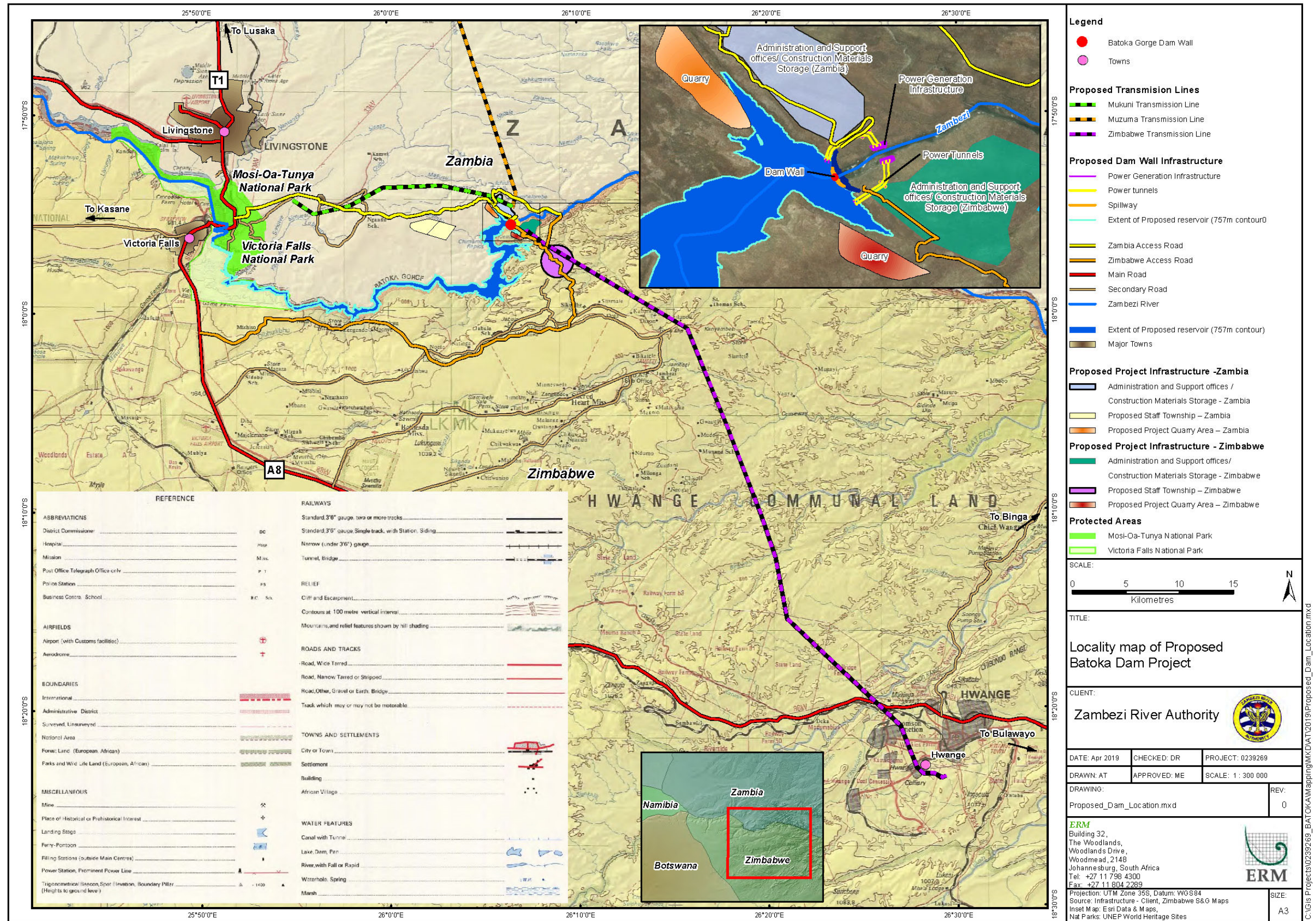

It is unlawful for any firm or individual to reproduce copyrighted maps, graphics or drawings, in whole or in part, without permission of the copyright owner, ERM Southern Africa (Pty) Ltd ©

Figure 1.2 Proposed Dam Site Location (2)

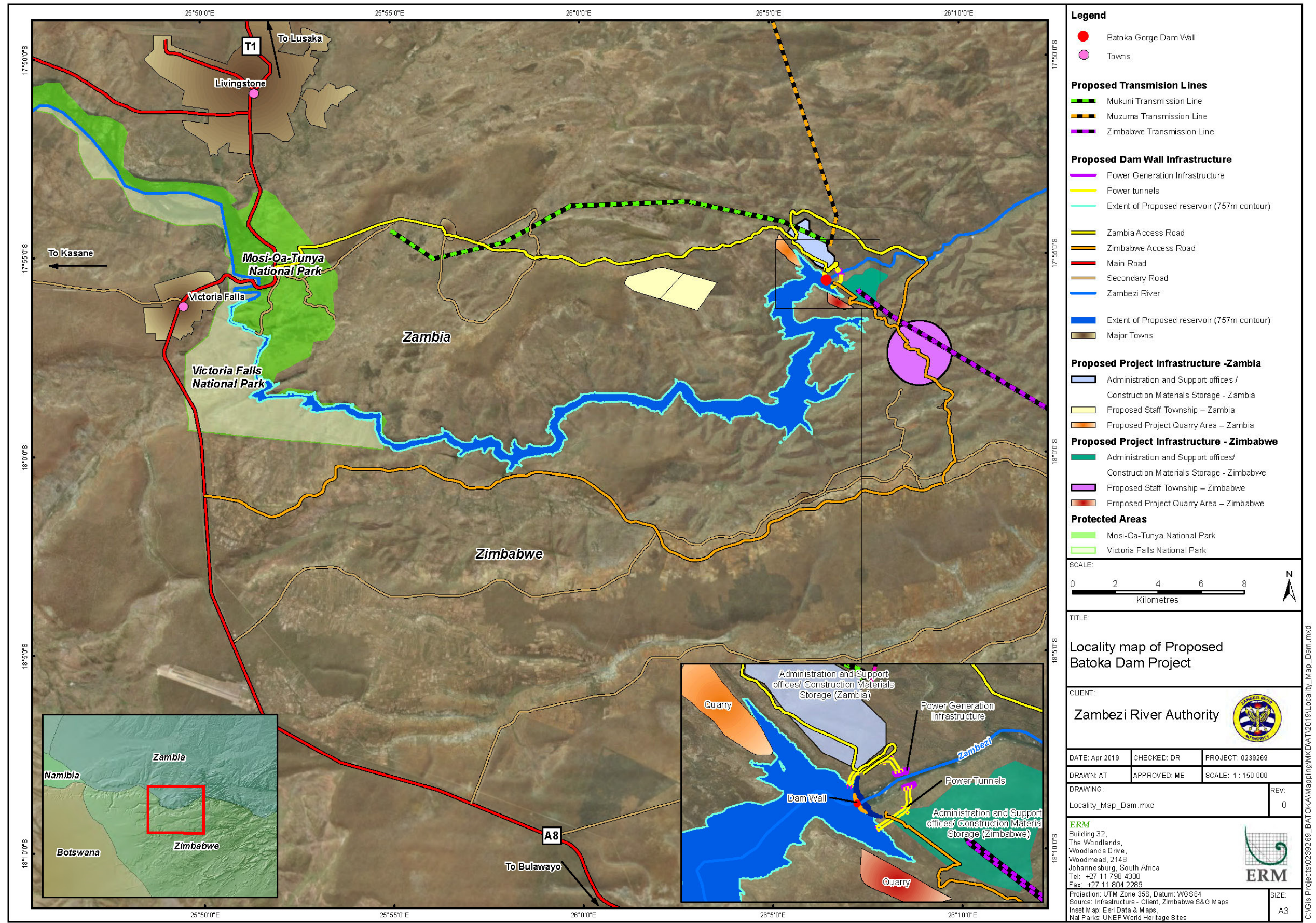

PURPOSE AND OBJECTIVES OF THIS CESMP

This CESMP has been prepared to cover the activities associated with the construction of the BGHES. The purpose of this CESMP is to outline appropriate management strategies and actions specifically for dam wall and impoundment, including a spillway; surface power houses, one on each side of the river; and project townships (in both Zambia and Zimbabwe) and other ancillary infrastructure (such as quarries, spoils area and batching areas), in order to meet acceptable levels of environmental and social performance. The purpose is also to provide a basis for an on-site environmental and social manual for staff, maintenance personnel, contractors and consultants with responsibilities for the Project.

The objective of the CESMP is to provide:

- Environmental and social management procedures and mitigation measures for the control of impacts of the Project to ensure that environmental and social requirements are specified and complied with;
- Measures to enhance positive impacts;
- Environmental and social monitoring requirements and review procedures for the Project activities;
- Government authorities, stakeholders and proponents with a common focus for approvals and compliance with relevant policies, authorisations, licences, agreements, legislation and other requirements; and
- The community with a tool to ensure that the environmental and social management of the Project is acceptable.

The Zambezi River Authority (ZRA) will have ultimate responsibility for implementing this CESMP.

STRUCTURE OF THIS CESMP

This CESMP provides:

- The policy, legislation, guidelines and standards against which environmental and social aspects need to be managed;
- The institutional arrangements required for governance, implementation, monitoring and reporting;

- A description of the range of management specifications required for the management of environmental, social, and health and safety aspects as a result of construction works;
- The specific monitoring specifications for pre-construction and construction phases for the specific Project components.

2.1 OVERVIEW

This CESMP details the required mitigation measures, and is partly prescriptive, identifying specific people or organisations to undertake specific tasks in order to ensure that impacts on the environment are minimised during the pre-construction construction phases. It is a dynamic document implying that information gained during pre-construction, site establishment and the construction works and monitoring on the site could lead to changes in this CESMP. This CESMP has been compiled prior to the implementation of any activities on site and thus falls within the Planning phase of the Project. Further stages of management including doing, checking and acting are required for the implementation of an effective Environmental and Social Management System (ESMS).

2.2 ENVIRONMENTAL AND SOCIAL MANAGEMENT SYSTEM

An effective ESMS is a dynamic and continuous process initiated and supported by a client/proponent, and involves engagement between the client, its workers, local communities directly affected by the project (the Affected Communities) and, where appropriate, other stakeholders (see *Figure 2.1*). Drawing on the elements of the established business management process of “plan, do, check, and act”, the ESMS entails a methodological approach to managing environmental and social risks and impacts in a structured way on an ongoing basis. A good ESMS appropriate to the nature and scale of the project promotes sound and sustainable environmental and social performance, and can lead to improved financial, social, and environmental outcomes.

The main elements of this approach comprise the following:

- **Planning:** Establishing actionable steps and key performance indicators, necessary to deliver results in compliance with regulations and obligations.
- **Doing:** Implementation of actionable steps, and assigning responsibilities for undertaking or implementing these requirements.
- **Checking:** Monitoring and measuring performance against key performance indicators, and other requirements, and reporting of the results.
- **Acting:** Taking actions to continually improve performance of this CESMP through the training of personnel and auditing of results.

Figure 2.1 Elements of an Environmental and Social Management System

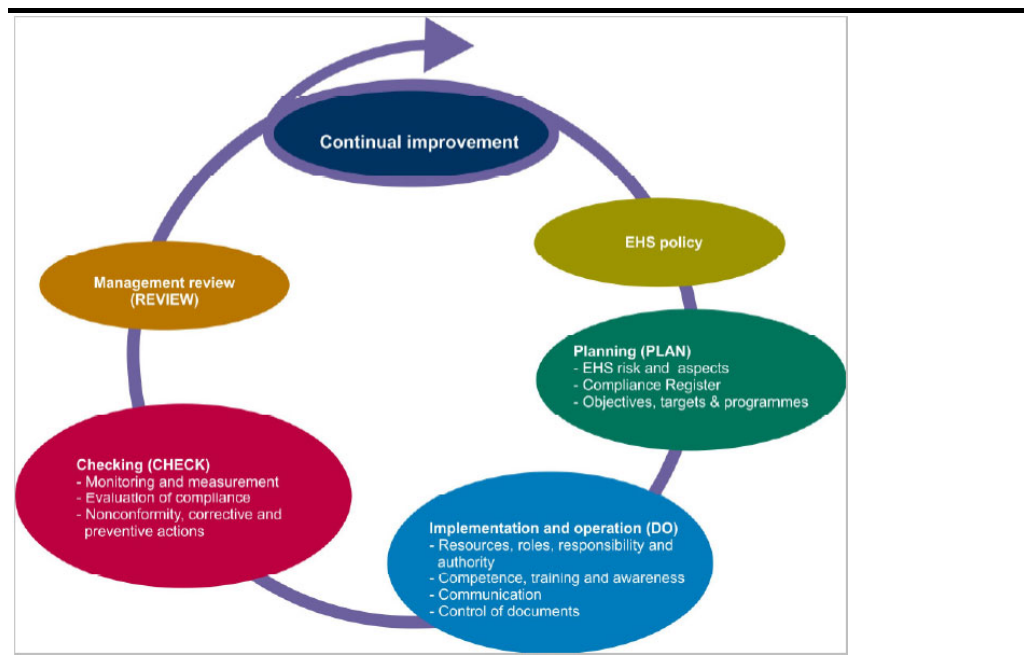

2.3 CHANGE MANAGEMENT

As Project design is finalised, design changes may occur that need to be accommodated by the ZRA and its associated contractors. Similarly, the organisational structure and roles and responsibilities included in this CESMP may also change as the Project progresses.

This CESMP will require a mechanism to manage change. At times these changes may be material, potentially influencing the original findings of the ESIA, and hence, the basis for its approval. Such a mechanism to manage change, or a change management system, must ensure that changes to the scope of the Project are subjected to a robust social and environmental assessment process. Any changes to Project scope will be evaluated for their degree of significance, and will be incorporated into the appropriate ZRA documentation as follows:

- Minor changes will be reflected in updates to this CESMP; and
- Substantive design / technology changes that might potentially alter the ESIA findings (i.e. those that result in changes to the predicted significance of environmental and social impacts) will be subject to re-assessment, further stakeholder consultation, supplementary reporting and revision of this CESMP. Typically, such substantive changes will be submitted as an addendum to this CESMP.

The key role-players for the purposes of environmental and social management on the site, include but are not limited to:

- The Developer (ZRA or Special Purpose Vehicle (SPV));
- The Engineering Team;
- The Main Contractors (direct appointments including civil works contractor, building contractor, landscape contractor etc.), and their Sub-contractors;
- The Safety Health Environmental and Quality (SHEQ) Manager;
- Representatives of the relevant Zambian and Zimbabwean Authorities; and
- Any lenders that provide funding for the Project.

Details of the responsibilities of each of the key role-players have been provided in to *Section 2.4.1 to Section 2.4.5* below. Lines of communication and reporting between the various parties are illustrated in *Figure 2.2* below.

Figure 2.2 *Lines of Communication and Reporting*

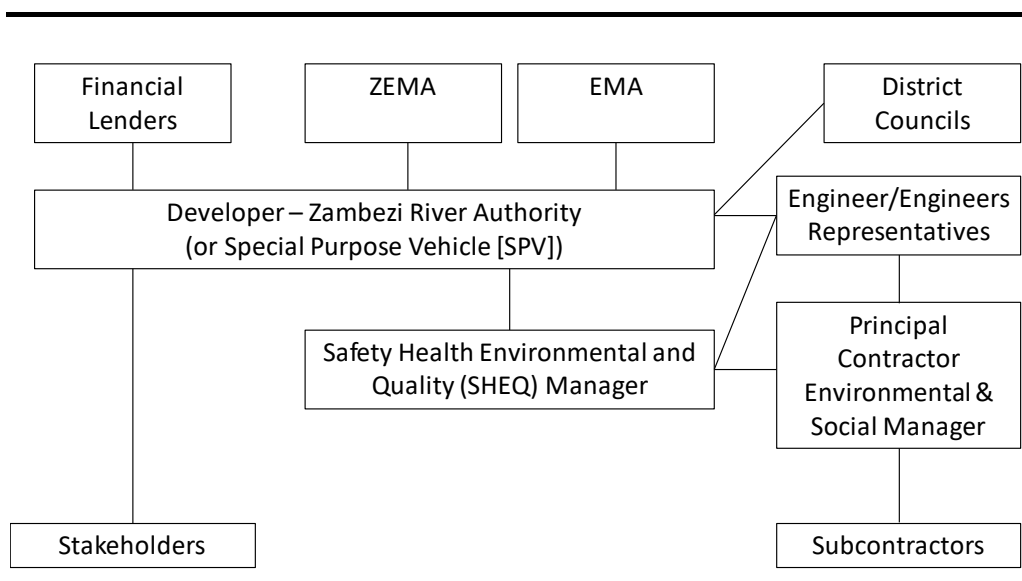

2.4.1

The Developer

For the purpose of this document, “the Developer” and its appointed facilitators refers to those to whom permission has been granted to proceed with the

proposed BGHES (i.e. – the ZRA or SPV ⁽¹⁾) and who is thus ultimately responsible for compliance with all conditions of approval of the Project or any aspect thereof by any authority.

ZRA was formed by the Zambezi River Authority Act of 1987 (Act No. 17 and 19 Zambia and Zimbabwe respectively) and is governed by a Council of Ministers consisting of four members: two are Ministers in the Government of the Republic of Zambia; and two are Ministers in the Government of Zimbabwe. The Ministers are those holding portfolios of Energy and Finance in the respective countries.

The functions of ZRA are set out in the schedule to the Act, and are as follows ⁽²⁾:

- Operate, monitor and maintain the Kariba Complex ("Kariba Complex means: the Kariba Dam and reservoir, all telemetering stations relating to the Kariba Dam, any other installations owned by the Authority");
- In consultation with the National Electricity Undertakings, investigate the desirability of new dams on the Zambezi River and make recommendations thereon to the Council;
- Subject to the approval of the Council, construct, operate, monitor and maintain any other dams on the Zambezi River;
- Collect, accumulate and process hydrological and environmental data of the Zambezi River for the better performance of its functions and for any other purpose beneficial to the Contracting States;
- In consultation with the National Electricity Undertakings, regulate the water level in the Kariba reservoir and in any other reservoir owned by the Authority;
- Make such recommendations to the Council as to ensure the effective and efficient use of the waters and other resources of the Zambezi;
- Liaise with the National Electricity Undertakings in the performance of its functions that may affect the generation and transmission of electricity to the Contracting States;
- Subject to provisions of Article 13 of the Act, recruit, employ and provide for the training of such staff as may be necessary for the performance of its functions under the Agreement;
- Submit development plans and programmes to the Council for approval;
- Give effect to such directions, as may from time to time, be given by the Council; and
- Carry out such other functions as are provided for the Agreement or are incidental or conducive to the better performance of its functions.

(1) The Developer (ZRA) may proceed with the Project independently or through a Special Purpose Vehicle (SPV) that would consist of the ZRA and other Government Departments.

(2) ZRA, 2014, Functions, <http://www.zaraho.org.zm/functions.html>

The Project Proponent's physical address and contact details are provided below:

Project Proponent	Physical address	Postal address
Chief Executive Officer Zambezi River Authority	Kariba House 32 Cha Cha Cha Road Lusaka, Zambia	P.O. Box 30233 Lusaka, Zambia

With respect to the pre-construction phase of the development, the developer is to:

- Implement the recommendations outlined in the pre-construction component of this CESMP; and
- Implement as many recommendations as possible that will lessen the total environmental impact of the proposed Project from the design stage, through to construction and ultimately the operational phase.

With respect to the construction phase of the development, the Developer is to:

- Ensure that all relevant approvals and permits have been obtained prior to the start of construction activities on the site.
- Ensure that this CESMP has been approved by the Zambian Environmental Management Agency (ZEMA) and the Zimbabwean Environmental management Agency (EMA) prior to the start of construction activities on the site.
- Ensure that the Contractor complies with the requirements of this CESMP, by including the CESMP as a condition of Contract, and that Contractors have provided appropriately qualified staff and realistic costs for the implementation of the CESMP.
- Ensure that the ZEMA and the EMA have been notified of the date on which construction activities associated with this CESMP will be starting, prior to commencement of the activity.
- Ensure that all conditions of approval have been complied with.
- Appoint suitably qualified or experienced Safety Health Environmental and Quality (SHEQ) Manager prior to the start of construction activities, and for the duration of the construction phase.

- Undertake internal audits of this CESMP to ensure compliance with regulatory requirements as well as the ZRA's own health, safety and environmental standards and policies.

The ZRA, as the Project proponent, have placed contractual obligations on the Engineer and the Contractor (with flow down requirements in relation to subcontractors), which have been considered in this CESMP, and which need to be adhered to, and reported on, through the implementation of the ESMS.

2.4.2 *The Engineer*

For the purposes of this document, "The Engineer" refers to the engineering firm for the Project, or any other person authorised by the Developer, to be responsible for the technical and contractual implementation of the works to be undertaken.

The responsibilities of the Engineer are to:

- Coordinate and ensure that the requirements as set out in this CESMP and any other conditions stipulated by the relevant Authorities are implemented by all parties with environmental and social responsibilities during the construction phase.
- Assist the SHEQ Manager in ensuring that the conditions included in this CESMP are adhered to and to promptly issue instructions requested by the SHEQ Manager to the Contractor. All instructions relating to environmental and social matters issued by the Engineer at the site to the Contractor are to be copied in writing to the SHEQ Manager.
- Assist the SHEQ Manager in making decisions and finding solutions to environmental and social problems that may arise during the construction works.
- Review and approve work method statements with input from the SHEQ Manager.
- Order the removal of person(s) and/or equipment not complying with the specifications (as required by the SHEQ Manager or otherwise).
- Provide input into the SHEQ Manager on-going internal review of this CESMP.

2.4.3 *The Contractor*

For the purposes of this document "The Contractor" refers to any company or individual appointed by the Developer to implement any aspect of the works.

The Contractor is to:

- Implement the conditions of this CESMP, associated sub-level management plans and development of any method statement during all works on the site, including all additional requirements as may be contained in approved method statements.
- Produce all Method Statements cited in this CESMP, and any other Method Statements deemed necessary during implementation of this CESMP.
- Ensure that all sub-contractors, employees, suppliers, agents etc. are fully aware of the environmental and social requirements detailed in this CESMP.
- Liaise closely with the Engineer and the SHEQ Manager and ensure that the works on the site are conducted in an environmentally and socially controlled manner.
- Inform the Engineer as well as the SHEQ Manager should environmental and social conditions on the site deteriorate, e.g. dumping, pollution, littering and damage to vegetation, community grievance.
- Carry out instructions issued by the Engineer, on request of the SHEQ Manager, required to comply with this CESMP.

The Contractor shall designate a permanent onsite employee as the Environmental and Social Manager who shall be responsible for undertaking a daily site inspection to monitor compliance with this CESMP. The Contractor shall submit the name of the Contractor's Environmental and Social Manager to the Engineer for approval prior to the commencement of the construction works. The Contractor's Environmental and Social Manager is to have a team of qualified officers to assist in implementation of this CESMP.

2.4.4 *The Safety Health Environmental and Quality (SHEQ) Manager*

For the purposes of this document "SHEQ Manager" refers to any company or individual appointed by the Developer to ensure (amongst other health and safety and quality responsibilities) the implementation of this CESMP.

In the context of this CESMP, during the construction phase, the SHEQ Manager is to:

- Ensure that the Contractor has a copy of this CESMP and all agreed method statements.

- Undertake regular inspections (with frequency determined by the nature of the on-site activities as may be appropriate) in the Project Area of influence to audit compliance of all parties with the requirements of this CESMP.
- Advise/make recommendations on actions or issues impacting on the environment to the Engineer, who shall issue any required site instructions to the Contractor.
- Conduct awareness training with the Contractor and all staff on key requirements of this CESMP, environmental and social safeguards, good housekeeping practices, and general aspects relating to site sensitivity.
- Review and approve method statements together with the Engineer (when applicable).
- Assist the Contractor in finding responsible solutions to environmental and social problems that may arise.
- Recommend to the Engineer the removal of person(s) and/or equipment not complying with the requirements of this CESMP.
- Undertake photographic monitoring of the construction works at the site.
- Keep records of all activities/ incidents concerning the environmental and social issues on the site in a site diary / logbook.
- Take immediate action on the site to stop works where significant and irreparable damage is being inflicted on the environment, and to inform the Engineer immediately of the occurrence and action taken.
- Undertake regular (monthly) internal audits of this CESMP and make recommendations regarding its updating to the Engineer and Developer.
- The SHEQ Manager to appoint a team of Officers to assist in compliance auditing, training, reporting, etc.

The SHEQ Manager will compile a monthly report of concerns and general compliance of the Contractor with the construction works requirements of this CESMP. The SHEQ Manager's monthly report will be submitted to the Engineer and if required, to the ZEMA, the EMA and the relevant District Councils. The SHEQ Manager is also required to attend regular meetings of the project management team to report on environmental and social issues and to minute the requirements that emerge.

The SHEQ Manager will be responsible for the compilation of a final completion checklist for the specific Project components specific to this CESMP (refer to

Section 1.1 for these specific project components), when all construction works related to these components have terminated and the site has been cleared of all construction related debris, materials or equipment not forming part of the permanent works. The completion checklist will audit the Contractor's compliance with the construction works requirements of this CESMP throughout the duration of the works and, together with a final written report, will be submitted to the ZEMA and the EMA and where appropriate to the relevant lenders in order to achieve "environmental and social closure" for the construction phase of the Project.

2.4.5 ZRA Community Relations

The ZRA should continue to engage with stakeholders throughout the Project in accordance with a Community Engagement Plan, which will need to be developed during the Pre-Construction Phase.

The objectives of communication and liaison with local communities are the following:

- To provide residents in the vicinity of the Project and other interested stakeholders with regular information on the progress and awareness of work and its implications.
- To monitor implementation of mitigation measures and the impact of the Project on communities via direct monitoring and feedback from those affected, in order to ensure the mitigation objectives are achieved.
- To manage any disputes between the ZRA, the Contractors and local communities.

A Grievance Redress Mechanism will be utilised for the submission and addressing of grievances as per the procedure set out therein (*Annex A*).

2.4.6 Communication Channels

The SHEQ Manager is required to attend regular meetings of the project management team to facilitate the transfer of information and to update all parties on the environmental and social compliance of the Project as a whole. The SHEQ Manager or delegated person will minute the discussions, and specifically any decisions arising relating to environmental and social management actions and responsibility.

The SHEQ Manager will compile a summary report outlining the main construction works relating to the environment, aspects of non-compliance, and document agreed environmental and social actions and dates of achieving

compliance by the Contractor. The summary report will form part of the construction works CESMP records.

The following people should attend these meetings:

- Developer's Representative;
- Engineer;
- The SHEQ Manager; and
- Contractor(s) representative (e.g. Site Manager).

2.4.7 *Environmental and Social Education and Awareness*

The Contractor, in consultation with the SHEQ Manager, shall arrange for a presentation to site staff to familiarise them with the environmental and social requirements of this CESMP within fourteen days from the commencement date of the works. This presentation should take cognizance of the level of education, designation and language preferences of the staff. General site staff would commonly receive a basic environmental and social awareness presentation or talk highlighting general environmental and social "do's and don'ts", including good housekeeping practices. This information would be provided throughout the works in the form of regular toolbox talks. Management level staff on the site, e.g. site agents and foremen, who require more detailed knowledge about the environmental and social sensitivities on site and the construction works requirements of this CESMP, will benefit from a separate and more detailed presentation of these issues. If required, the SHEQ Manager may call upon the services of a professional trainer or environmental consultant to present the technical contents of this CESMP. Environmental and social education of staff can be assisted by compilation of posters placed in staff venues e.g. canteens and site offices.

2.4.8 *Method Statements*

The Contractor shall compile and provide Method Statements to the SHEQ Manager and the Engineer for approval prior to the construction works commencing. Method Statements will be required for specific activities that are deemed or identified to pose a risk to the environment and/or which require site-specific detail beyond that contained in this CESMP or when requested by the Engineer or SHEQ Manager.

A Method Statement is a dynamic document in that modifications are negotiated between the Contractor and the SHEQ Manager /project management team, as circumstances unfold. Changes to, and adaptations of, Method Statements can be implemented with the prior consent of all parties. All Method Statements will form part of the construction works of the CESMP documentation and are subject to the terms and conditions contained within the CESMP.

Note that a Method Statement is a starting point for understanding the nature of the intended actions to be carried out and allows for all parties to review and understand the procedures to be followed in order to minimise risk of harm to the environment.

A Method Statement describes the scope of the intended work in a step-by-step manner, in order for the SHEQ Manager and the Engineer to understand the Contractor's intentions.

For each instance where it is requested that the Contractor submit a Method Statement to the satisfaction of the Engineer and SHEQ Manager, the format should clearly indicate the following:

What - a brief description of the work to be undertaken;

How - a detailed description of the process of work, methods and materials;

Where - a description/sketch map of the locality of work (if applicable);

When - the sequencing of actions with due commencement dates and completion date estimates;

Who - The person responsible for undertaking the works described in the Method Statement; and

Why - a description of why the activity is required.

All Method Statements must be developed to the satisfaction of the SHEQ Manager, Engineer and, where practical or stipulated in the Environmental Licence, should be endorsed as being acceptable by a representative of the ZEMA and the EMA.

A list of possible Method Statements that the Contractor may be required to submit prior to the start of works on the site is provided in *Section 4.4* and a method statement template in *Annex B*.

2.4.9 *Dispute Resolution*

Any disputes or disagreements between role players on the site (with regard to environmental and social management) will firstly be referred to the Engineer during construction. If no resolution on the matter is reached the Developer will be consulted and reference made to the Contractors contract.

2.5 *TRAINING FOR IMPLEMENTATION OF THIS CESMP*

A main element of the ESMS (refer to *Section 2.2*) is to take actions to continuously improve the performance of this CESMP through training of personnel. In addition to the training of Contractors on the requirements of this CESMP, it is incumbent for the ZRA to convey the sentiments of the CESMP to all ZRA personnel responsible with the implementation of this CESMP.

Accordingly, the ZRA will contract a suitably qualified environmental and social specialist to develop and execute training on capacity strengthening for those ZRA staff that are responsible for implementation of this CESMP.

Training courses will cover:

- Details on implementing and monitoring the Environmental and Social Management System (ESMS).
- Details on the environmental and social responsibilities of the ZRA and other key role players.
- Lines of communication and reporting between various parties during the life of the Project.
- Environmental (including social) permitting / licensing requirements for the Project.
- An overview of the Project related activities that will result in environmental and social impacts if not managed.
- Details on any environmentally and socially sensitive areas.
- The objective and details of method statements, including the approval process for these.
- The environmental and social management actions that need to be undertaken during all phases of the Project, responsibilities for implementing these actions and the timing / frequency of these actions.
- Monitoring / auditing requirements that need to be undertaken during all phases of the Project, responsibilities for monitoring /auditing and the timing / frequency of monitoring /auditing activities.
- Environmental and social reporting and documentation requirements for government / authority reporting; lender reporting; internal reporting and community reporting.

The ZRA will ensure that a document exists that clearly lists who will require training, the frequency of training and the procedure to document training activities.

Courses shall be run during normal working hours at a suitable venue provided by the ZRA. All attendees shall remain for the duration of the course and sign an attendance register on completion that clearly indicates participant's names.

This *Chapter* presents a summary of the following national and international legal requirements and standards relevant to the CESMPs and OESMP (cumulatively referred to in this *Chapter* as the ESMPs) associated with the greater BGHES:

- *Zambian Legal Requirements and Standards (refer to Table 3.1)*
- *Zimbabwean Legal Requirements and Standards (refer to Table 3.2)*
- *International Guidelines and Standards (refer to Table 3.3), including –*
 1. *World Bank Group Environmental and Social Safeguard Policies*
 2. *International Finance Corporation (IFC) Performance Standards*
 3. *International Finance Corporation (IFC) Environmental, Health and Safety (EHS) Guidelines*
 4. *African Development Bank Group’s Integrated Safeguard System and Operational Safeguards*

It should be noted that the IFC EHS Guidelines do not only address the EHS expectations of the IFC, but also that of the World Bank group’s.

This *Chapter* provides a brief summary of these various legal requirements, standards and guidelines and describes the applicability of these to the ESMPs.

3.1

ZAMBIAN LEGAL REQUIREMENTS AND STANDARDS APPLICABLE TO THIS ESMP

Table 3.1 *Zambian Legal Requirements and Standards Applicable to this ESMP*

Aspect	Legislation, Standard and/or Guideline Document	Applicability to the Batoka Gorge Hydro- Electric Scheme ESMP
General Environmental Management	The Zambian Environmental Management Act (No. 12 of 2011)	<p>Section 4 mentions that every person living in Zambia has the right to a clean, safe and healthy environment and should a person be threatened or is likely to be threatened as a result of an act or omission of any other person, that person may bring an action against the person whose act or omission is likely to cause harm to human health or the environment.</p> <p>Moreover, Section 5 states that every person has a duty to safeguard and enhance the environment.</p> <p>The ESMPs have been prepared in support of the EIA Regulations.</p>
	The Environmental Impact Assessment (EIA) Regulations, which fall under the EPPCA (Statutory Instruments No. 28 of 1997)	<p>These Regulations provide the framework for conducting an Environmental Impact Assessment (EIA) and requires that an Environmental Management Plan (EMP) be developed that is in support of the EIA.</p> <p>In this respect the ESMPs have been developed.</p>

Aspect	Legislation, Standard and/or Guideline Document	Applicability to the Batoka Gorge Hydro- Electric Scheme ESMP
Permits	The Environmental Management (Licensing) Regulations (S.I. No. 112 of 2013)	<p>The Regulations were published under the Zambian Environmental Management Act (Act 12 of 2011) and provide for licensing and management requirements for -</p> <ul style="list-style-type: none"> • <u>Air Pollution Monitoring Permits</u> - under the Air Pollution Control (Licensing and Emission Standards) Regulations, 1996 • <u>Water Effluent Discharge Permits</u> - under the Water Pollution Control (Effluent and Wastewater) Regulations, 1993 • <u>Waste Management Licences</u> - under the Waste Management (Transporters of Waste/Operation of Waste Disposal Sites) Regulations, 1993 and Hazardous Waste Management Regulations, 2001 • <u>Pesticides and Toxic Substances Licences</u> - under the Pesticides and Toxic Substances Regulations, 1994 <p>These specific permits/licenses will need to be considered as part of final Project Design.</p>

Aspect	Legislation, Standard and/or Guideline Document	Applicability to the Batoka Gorge Hydro- Electric Scheme ESMP
Water	Water Resources Management Act (No. 21 of 2011)	<p>The Environmental and Social Impact Assessment needs to consider all project activities that may result in effluent discharge. The Environmental and Social Management Plan should include measures to manage such discharge and should include provisions to ensure that no person discharges or disposes of—</p> <ul style="list-style-type: none"> • any organic or inorganic matter, including water containing such matter, into a water resource, whether directly or through drainage or seepage, so as to cause pollution of the water resource; or • any effluent or waste water which has been produced by, or results from, the use of water for any purpose, into a water resource, whether directly or through drainage or seepage. <p>Please note that dilution of effluents using water is an activity that requires a licence. The licensing process is beyond the scope of this report.</p> <p>Management measures in relation to water resources have been considered in the ESMPs, particularly to the Zambezi River downstream of the proposed dam wall. Moreover, water permits ought to be obtained in accordance with Act 21 of 2011: Statutory Instrument (SI) 18 of 2018.</p>
	The Zambian Environmental Management Act (No. 12 of 2011)	Division 2, Sections 45 to 48 of the Act make considerations for water resources. More specifically, Section 46 states that a person shall not discharge or apply any poisonous, toxic, eco-toxic, obnoxious or obstructing matter, radiation or other pollutant, or permit any person to dump or discharge such matter or pollutant into the aquatic environment in contravention of water pollution control standards.
	Water Supply and Sanitation Act (No. 28 of 1997)	<p>The Environmental and Social Impact Assessment needs to consider the need for a clean potable water supply. The ESMPs should include measures to ensure sanitary conditions relating to the use of such water.</p> <p>Please note that all water service providers need to be licence and therefore before sourcing water from such a provider check that they are in possession of a licence.</p>

Aspect	Legislation, Standard and/or Guideline Document	Applicability to the Batoka Gorge Hydro- Electric Scheme ESMP
Terrestrial Ecology	Zambian Wildlife Act (No. 14 of 2015)	<p>Part VI (Game Animals and Protected Animals) includes provisions for game and protected animals. More specifically Section 31 of Part VI states that any person who hunts any game or protected animal, except under or in accordance with the conditions of a valid license issued under Part VII of this Act, shall be guilty of an offence. This is further reiterated in Section 67 of the Act.</p> <p>The Environmental and Social Impact Assessment needs to consider the impacts on flora and fauna within national parks, conservation and protected wildlife areas. The ESMPs present measures to manage such impacts on fauna and flora.</p>
	The Zambian Environmental Management Act (No. 12 of 2011)	<p>Section 77 (2) of Division 8 of the Act states that no person shall place any invasive alien species into any element or segment of the environment. Moreover, Section 78 states that an occupier of any land shall take such measures as are prescribed and are reasonably necessary for the eradication or prevention of the spread of invasive alien species.</p> <p>The control of alien species has been considered in the ESMPs.</p>
	Forests Act (No. 4 of 2015)	<p>The Environmental and Social Impact Assessment needs to consider the possible impacts upon national or local forests and protected tree species. The ESMPs include measures that minimises impacts to trees within such areas and that protected tree species, no matter their location, are not negatively impacted upon.</p>
Aquatic Ecology	National Policy on Wetlands Conservation (September 2001)	<p>This Policy was formulated in response to the fragmented sectoral policies and Acts. It aims to provide a holistic programme of action to promote the conservation and wise use of wetland ecosystems. It acknowledges the importance of wetland ecosystems in Zambia in providing major fisheries and as important habitats for various wildlife species.</p> <p>The management of surface water quality, aquatic environments (including aquatic vegetation) and terrestrial ecology (including fauna utilising wetland habits) is provided in the ESMPs. These have considered the provisions of this National Policy.</p>

Aspect	Legislation, Standard and/or Guideline Document	Applicability to the Batoka Gorge Hydro- Electric Scheme ESMP
	Fisheries Act (No. 22 of 2011)	The Environmental and Social Impact Assessment needs to consider impacts upon the fishing industry and ensure that such persons are involved in consultations. The ESMPs include measures to manage impacts upon such persons as far as is reasonably possible and a livelihood restoration plan, which will be compiled as part of the Project Resettlement Action Plan (RAP), will also ensure the minimization of impacts.
Noise	Part IV of Zambian Environmental Management Act (No. 12 of 2011)	Section 68 of Division 6 (Part IV) of the Act states that no person shall emit noise in excess of the noise emission standards established. The management of noise has been addressed as part of the ESMPs.
Air Quality	Part IV of Zambian Environmental Management Act (No. 12 of 2011)	Section 52 of Division 3 (Part IV) of the Act states that ambient air quality standards and guidelines shall be established under this Division and published.
	Section 37, 46 and 96 of Air Pollution Control (Licensing and Emission Standards) Regulations (S.I. No. 141 of 1996)	This regulation provides a table of guideline limits for ambient air quality pollutants including Sulphur Dioxide, Total Suspended Particulate, Particulate Matter, Carbon Monoxide, Ambient Lead and Dust Fall. The ESMPs have considered these regulations and associated ambient air quality standards.
Explosives	Explosives Act (No. 10 of 1974) Regulations are in draft stage.	Section 3 of the Act states that the Act shall apply (amongst others) to the storage, use, possession and transportation of explosives. Part I of the Act provides general measures for the storage, handling and use of explosives. Part III includes provisions for the transportation of explosives by waterway, road, rail or air; and Part IV includes provisions for the transportation of explosives around the work site. Part V includes provisions for the storage of explosives at the work site and Part VIII includes requirements for the use of explosives. The development of measures included in the ESMPs and detailed design around blasting management for BGHES has and will take these requirements into consideration.

Aspect	Legislation, Standard and/or Guideline Document	Applicability to the Batoka Gorge Hydro- Electric Scheme ESMP
Health	Factories Act (Chapter 441 of the Laws of Zambia) (as amended by S.I. No. 165 of 1989, No. 75 of 1990, and No. 13 of 1994)	<p>The Factories Act is intended to make further and improved provision for the regulation of the conditions of employment and regards the safety, health and welfare of persons employed therein.</p> <p>Part V (Health: General Provisions) of the Act includes provisions around cleanliness, overcrowding, ventilation, lighting and sanitary requirements for employees and Part VI (Safety: General Provisions) includes provisions for the use of machinery, training, facilities, precautions for the use of explosives, emergency drill training requirements for employees.</p> <p>Moreover, Part IX includes provisions for the welfare of employees, including provisions for drinking water, washing facilities, accommodation and change rooms, first aid and resting facilities. Section 71 of Part X includes requirements for provision of Personal Protective Equipment (PPE) and additional health and safety and welfare measures.</p> <p>The ESMPs have considered the provisions included in this Act.</p>
	Public Health Act (No. 22 of 1995)	This Act provides for the prevention of diseases, drainage, latrine and disposal of sewerage and treatment systems. The ESMPs have considered sewerage disposal activities and associated methods.
Energy	Energy Regulation Act (No. 16 of 1995)	<p>Provides for the control in the pricing and quality of energy products in the country.</p> <p>No direct issues to be complied with; however, the Energy Regulator is a key stakeholder and therefore needs to be included in consultations relating to the ESIA and the ESMPs.</p>
	The Petroleum Act (No. 28 of 1930)	The ESMPs consider the possible use of petroleum products and include measures to ensure that such products are handled, stored and transported in accordance with this Act.
	The Electricity Act (No. 15 of 1995)	The ESIA considers electrical transmission activities.

Aspect	Legislation, Standard and/or Guideline Document	Applicability to the Batoka Gorge Hydro- Electric Scheme ESMP
Health	Public Health Act (No. 22 of 1995)	Provides for the prevention of diseases, drainage, latrine and disposal of sewerage and treatment systems. The ESMPs have considered sewerage disposal activities and associated methods.
	The Occupational Health and Safety Act (Act No. 36 of 2010)	This Act provides for the establishment of health and safety committees at workplaces and for the health, safety and welfare of persons at work. Moreover, the Act provide for the protection of persons, other than persons at work, against risks to health or safety arising from, or in connection with, the activities of persons at work. The ESMPs have considered occupational health and safety aspects and associated mitigation thereof.
Roads and Traffic Safety	Roads and Road Traffic Act (Cap 464)	Part III and IV of this Act include provisions for the registration and licensing of motor vehicles and trailers. Such provisions include ownership details, vehicle/trailer specifications, etc. Moreover, Part V includes the requirements for the licensing of drivers of motor vehicles and Part VII includes the provisions for third part insurance. The Act stipulates that no person shall drive a motor vehicle on a road unless he is the holder of a valid licence issued to him in respect of motor vehicles of the class concerned. The Act provides the minimum age limits associated with driving of vehicles on roads. Part VI includes the provisions for motor vehicle insurance against third party. Part XI includes the provisions for road safety and driving offences (speed limits, reckless driving, driving under the influence, driving behaviours, vehicle emissions, littering etc.). The provisions of this Act have been included in the ESMPs.
Land Use Planning Issues	The Urban and Regional Planning Act (No. 3 of 2015)	The ESMPs ensure that project activities are in adherence with such developed plans as far as is reasonably possible.
	Lands Conversion of Titles Act	The ESMPs include provisions for the development and implementation of a RAP that take into account the provisions of these Acts.
	Lands and Deeds Registry Act (No. 38 of 1994)	

Aspect	Legislation, Standard and/or Guideline Document	Applicability to the Batoka Gorge Hydro- Electric Scheme ESMP
	Lands Act (No. 29 of 1995)	<p>The Act guarantees peoples' right to land while enhancing development. The Act recognises the holding of land under customary tenure and the Chief's role has been legally recognised, such that land cannot be converted or alienated without approval of the chief.</p> <p>The ESMPs include provisions for the development and implementation of a RAP that should take into account the provisions of this Act.</p>
	Land Acquisition Act (No. 2 of 1970)	<p>The Act sets out regulations for compulsory acquisition of land and property and compensation for such acquisition.</p> <p>The ESMPs include provisions for the development and implementation of a RAP that should take into account the provisions of this Act.</p>
	Agricultural Lands Act (No. 57 of 1960)	The ESMPs consider impacts upon on all agricultural land and ensures that the Minister is consulted as well as affected farmers.
	The Local Government Act (No. 19 of 1992)	The ESMPs consider impacts upon local or district council areas and the Council's jurisdiction over these areas.
Cultural Heritage	National Heritage and Conservation Act (Act No. 23 of 1989)	<p>Part V of this Act (Conservation of Heritage) states that (Section 35) any person who wishes to destroy, demolish, alter or remove from its original site any monument, relic or ancient heritage shall apply for permission to the Commission. Moreover, Section 37 states that any person who desires to excavate any ancient heritage or collect relics shall apply to the Commission for permission.</p> <p>In accordance with Section 42, any person who discovers a potential ancient heritage or relic shall report the find to the commissions and suspend operations in the immediate vicinity to the discovery.</p> <p>The ESMPs have considered the provisions of this Act.</p>

Aspect	Legislation, Standard and/or Guideline Document	Applicability to the Batoka Gorge Hydro- Electric Scheme ESMP
Employment and Compensation	Citizens Economic Empowerment Act (No. 9 of 2006)	<p>Provides for the encouragement and support of citizens of Zambia to get involved in business activities for wealth creation and support of livelihoods.</p> <p>More specifically, Part II of the Act provides measures for economic empowerment including (amongst others) the prohibition of discrimination, skills development, education and training, preferential procurement, regional development, codes of good practice and mechanisms for measuring progress.</p> <p>The ESMPs provide measures to ensure that the proposed BGHES provides opportunities to Zambian citizens.</p>
	The Employment Act (No. 57 of 1965)	The ESMPs include measures to ensure that all employees are appointed in accordance with the Act and that labor conditions provide for a safe and healthy environment.
	Compensation Act (No. 19 of 1973)	The ESMPs include measures that provide for the contribution to the Fund for disabled workers as required.
	Employment Code Act No. 3 of 2019	The ESMPs have considered the relevant requirements pertaining to employment included in this Act.
Mining - Quarries	Mines and Minerals Development Act (No. 11 of 2015)	<p>The ESMPs include measures for quarrying related activities.</p> <p>Please note that such activities will require licenses; however, the associated process is beyond the scope of this report.</p>
Tourism	Tourism and Hospitality Act (No. 23 of 2007)	The ESMPs include measures for the management of impacts to the tourism industry as far as is reasonably possible.

3.2

ZIMBABWEAN LEGAL REQUIREMENTS AND STANDARDS APPLICABLE TO THIS ESMP**Table 3.2 Zimbabwean Legal Requirements and Standards Applicable to this ESMP**

Aspect	Legislation, Standard and/or Guideline Document	Applicability to the Batoka Gorge Hydro- Electric Scheme ESMP
General Management Requirements	Constitution of Zimbabwe Amendment Act (No. 20 of 2013), Section 73 (Environmental Rights)	<p>According to Section 73 of the Constitution of Zimbabwe, every person has a right to an environment that is not harmful to their health or well-being and to have the environment protected for the benefit of present and future generations, through reasonable legislative and other measures.</p> <p>Other than Section 73, the current Constitution has no specific clause that provides for the protection of the environment.</p> <p>The objective of the ESMPs is to ensure the protection of the environment and associated key natural socio-environmental resources.</p>
	The Environmental Management Act (the Act) (Chapter 20:27), (No. 13 of 2002)	<p>This Act aims to provide for the sustainable management of natural resources and protection of the environment; [and] the prevention of pollution and environmental degradation.</p> <p>Section 4 the Act affords all citizens of Zimbabwe the right to live in a clean environment that is not harmful to their health; access to environmental information; the right to protect the environment for the benefit of present and future generations; and the right to participate in the implementation of legislation and policies that prevent pollution and environmental degradation and promote the sustainable management and use of natural resources, as well as justifiable economic and social development.</p> <p>The Act also includes provisions for aspects including (amongst others) water, air, waste, hazardous wastes, noise, toxic substances, wetlands and control of invasive plant species. These provisions will be discussed in the relevant sections below.</p> <p>The ESMPs have taken these provisions into account.</p>

Aspect	Legislation, Standard and/or Guideline Document	Applicability to the Batoka Gorge Hydro- Electric Scheme ESMP
	Environmental Management (Environmental Impact Assessments and Ecosystems Protection) Regulations (S.I. No. 7 of 2007)	<p>The Environmental Management Regulations deal with the regulation of the EIA process and the protection of ecosystems.</p> <p>In this respect, ESIA's and associated ESMP's has been developed. The Project will not go ahead until approval is obtained from the ZEMA and the EMA.</p>
	Environmental Impact Assessment Policy of 1997	<p>The goal of the policy is to encourage environmentally responsible investment and development in Zimbabwe. The policy views the EIA process as key to achieving this goal. To support the 1997 Environmental Impact Assessment Policy, the Ministry published EIA Guidelines to facilitate the implementation of the EIA process. These guidelines are presented as 10 Volumes. Volume 1 of the guidelines provides guidance on aspects of environmental management. Volumes 2 to 10 provide guidance on sector-specific EIAs (including hydropower and transmission lines), and (amongst others) provides measures for managing impacts.</p> <p>The ESMP's have taken the provisions included in these guidelines into account.</p>
Water	Water Act of 2003 (Chapter 20:24)	<p>Section 67 of the Act states that water resource management needs to be consistent with environmental approaches and due consideration should be given to the protection, conservation and sustenance of the environment; and the right of access by members of the public to places of leisure or natural beauty related to water or water bodies.</p> <p>According to Section 69, a person who intends to discharge or dispose into a water course shall apply for a permit and pay such charges, for the use of the water, as may be prescribed. It is the understanding of this process that a water permit will not be necessary for this Project.</p> <p>Part IX includes provisions on the safety of dams. Namely Section 109 and 110 include requirements around procedures for emergency for any sudden or unprecedented flood or alarming or unusual circumstance or occurrence, whether anticipated or existing, which may adversely affect the dam.</p> <p>Such management measures have been considered in the ESMP's.</p>

Aspect	Legislation, Standard and/or Guideline Document	Applicability to the Batoka Gorge Hydro- Electric Scheme ESMP
Terrestrial Ecology	The Environmental Management Act (the Act) (Chapter 20:27) (No. 13 of 2002)	<p>Section 57 of the Act mentions that any person, who discharges or applies any poison or toxic, noxious or obstructing matter, radioactive waste or other pollutants or permits any person to dump or discharge such matter into the aquatic environment in contravention of water pollution control standards shall be guilty of an offence.</p> <p>This provision has been duly noted in the ESMPs.</p>
	Forest Act of 1948 (Chapter 19:05)	<p>Provides for demarcating and conserving forests and nature reserves.</p> <p>More specifically, Part VI (conservation of timber resources) governs the removal of indigenous trees. Prior to the removal of indigenous trees, notice of intention must be provided to the appropriate Commission.</p> <p>Management/mitigation commitments for the protection of terrestrial flora are included in the ESMPs.</p>
	Parks and Wildlife Conservation Act of 1975 (Chapter 20:14)	<p>Provides for the conservation and control of wildlife, fish and plants; and designates specially protected animals and indigenous plants.</p> <p>More specifically, Part IX (specially protected animals) (Section 45) and Part XII includes provisions around the hunting, removal of animals and animal products.</p> <p>Part X and Part XI of the Act include provisions for protected plants specified in the Seventh Schedule (insertion by Act 19 of 2001 with effect from the 1st June, 2002) and provisions for the control of picking of indigenous plants.</p> <p>The ESMPs have been compiled in light of the requirements of this Act.</p>
	The Environmental Management Act (the Act) (Chapter 20:27) (No. 13 of 2002)	<p>Part XIII of the Act includes provisions for the control of alien plant species. Essentially, every person has the responsibility to clear or cause to be cleared any invasive alien species growing or occurring on the land in respect of which he is responsible.</p> <p>The ESMPs have been compiled in light of the requirements of this Act.</p>

Aspect	Legislation, Standard and/or Guideline Document	Applicability to the Batoka Gorge Hydro- Electric Scheme ESMP
	Communal Land and Forest Produce Act of 1988 (Chapter 19:04)	The ESMPs consider impacts to natural resources (such as trees) on communal lands, as the local communities have use rights with regard to the use of such resources. Impacts / loss of natural resources used by local communities will be assessed as part of the RAP process.
Aquatic Environment	GN 380 of 2013 (Protection of Wetlands) per Section 113 of the Environmental Management Act (the Act) (Chapter 20:27) (No. 13 of 2002)	This Section of the Act includes provisions for the protection of wetlands in Zimbabwe. Such controls include the preservation of beds, banks; controlling stormwater; restrictions of removing clays and deposits from wetlands; reducing pollution of any kind to wetlands and restoration of wetlands. Measures associated with the management of surface water quality, aquatic environments (including aquatic vegetation) and terrestrial ecology (including fauna utilising wetland habits) are provided in the ESMPs.
	Air Pollution Control Regulations (S.I. No. 72 of 2009) of the Environmental Management Act of 2002	Provides for prevention, control and abatement of air pollution to ensure clean and healthy ambient air. The ESIA's have considered possible emission sources associated with proposed Project activities. This may relate to, for example, motor vehicles and generators used during construction activities. As such, air pollution control measures have been included in the ESMPs.
	The Environmental Management Act (the Act) (Chapter 20:27) (No. 13 of 2002)	Section 63 of the Act mentions that ambient air quality standards need to be established.
Air	Draft Air Quality and Emission Standards (draft number EN 005 - D977/2) of the Environmental Management Act of 2002	These have not been enacted; however, Section 4 of these draft standards provides ambient air quality in Zimbabwe. Moreover, Section 7 provides limit values for vehicle emissions.

Aspect	Legislation, Standard and/or Guideline Document	Applicability to the Batoka Gorge Hydro- Electric Scheme ESMP
Noise	The Environmental Management Act (the Act) (Chapter 20:27) (No. 13 of 2002)	<p>Sections 79 to 81 (in Part IX of the Act) provide requirements around noise management. More specifically, the Act mentions the need for standards to be established for the emissions of noise and vibration pollution. Section 80 mentions that any person who emits noise in excess of the noise emission standards prescribed in terms of section seventy-nine shall be guilty of an offence.</p> <p>No reference to noise standards could be sourced and it appears as if these do not yet exist.</p> <p>The ESMPs include noise mitigation measures.</p>
Waste	<p>Effluent and Solid Waste Disposal Regulations (S.I. No. 6 of 2007) of the Environmental Management Act of 2002</p> <p>Hazardous Waste Management Regulations (S.I. No. 10 of 2007) of the Environmental Management Act of 2002</p>	<p>This regulation concerns the disposal of effluent and solid wastes. Persons are prohibited from disposing waste into public water courses without initially acquiring permission. Moreover, a generator of waste (other than domestic households) is now required to produce a Waste Management Plan on an annual basis. The plan should deal with sound environment management of wastes and include information on: quantity of waste; components of waste, goals for the reduction of the quantity and pollutant discharges of the waste; transportation and disposal of waste; and adoption of environmentally sound management of wastes.</p> <p>The ESMPs consider activities that will result in disposal of waste into water sources. Such activities may require a license; however, the details of obtaining such a license are beyond the scope of this report.</p> <p>Provides for the licensing for generation, storage, use, recycling, treatment, transportation or disposal of hazardous waste. Generators of hazardous waste are also required to prepare waste management plans and targets. Regulates waste collection and management by local authorities. In addition, regulates the importation and exportation of hazardous waste and waste oils.</p> <p>According to this regulation, generators of hazardous waste are required to prepare waste management plans.</p> <p>Waste management has been taken into consideration in the ESMPs.</p>

Aspect	Legislation, Standard and/or Guideline Document	Applicability to the Batoka Gorge Hydro- Electric Scheme ESMP
Explosives	Plastic Bottles and Plastic Packaging Regulations (S.I. No. 98 of 2010)	<p>This regulation encourages a reduction in the use of certain types of plastics. According to Article 3(1), it is prohibited to produce, import or distribute plastic packaging with a thickness of less than 30 microns.</p> <p>The ESMPs encourage minimisation of waste generation and maximisation of reuse and recycling of waste products.</p>
	The Environmental Management Act (the Act) (Chapter 20:27) (No. 13 of 2002)	<p>Section 69 of Part IX of the Act mentions that no person shall discharge or dispose of any wastes, whether generated within or outside Zimbabwe, in such a manner as to cause pollution to the environment or ill health to any person. Moreover, Section 69 includes provisions for the transport and disposal of waste.</p> <p>Section 73 of the Act prohibits the discharge of hazardous substances, chemicals and materials or oil into the environment.</p> <p>The appropriate management of waste has been included in the ESMPs.</p>
	Explosives Act (Chapter 10:08) and Explosives (Amendment) Regulations (S.I. No. 139 of 1995)	<p>Part IV of the Regulations includes provisions for the storage of explosives. No person shall keep explosives in or on any premises unless the premises are licensed. Moreover, Part V of the Regulations govern the use of explosives. Part VI provides restrictions and provisions for the transport of explosives.</p> <p>The ESMPs presents blasting management measures. The development of these measures have taken these Regulations into consideration.</p> <p>Licenses for the use and storage of explosives may need to be obtained. The licensing process is beyond the scope of the ESMPs.</p>
	Statutory Instrument No. 109 of 1990 (Mining (Management and Safety) Regulations of the Mines and Minerals Act of 1961	The Regulation provides requirements for the surface protection and protection of working places associated with mining works. Mining can be defined as a process of extracting or obtaining minerals, and any process directly (or indirectly) connected therewith. Accordingly, the requirements included in this Regulation will be of relevance to the Project Quarries.

Aspect	Legislation, Standard and/or Guideline Document	Applicability to the Batoka Gorge Hydro- Electric Scheme ESMP
Hazardous Substances	Statutory Instrument No. 268 of 2018 of the Environmental Management Act of 2002 (Hazardous Substances, Pesticides and other Toxic Substances)	<p>The Regulation provides for the labelling, packaging, repackaging and sale of hazardous substances or articles containing hazardous substances in Zimbabwe.</p> <p>The Regulations prescribe conditions that employers have to observe in the handling of hazardous substances at the workplace, conditions for transporting hazardous substances, and procedures to be followed when there is an accidental spillage of hazardous substances.</p> <p>The Agency is empowered to issue spot fines to any person who violates the law. In addition, any person whose substances affect the environment is liable to pay for the cost of restoring the environment (i.e. the polluter pays principle). The offender is also liable to pay compensation for any damage that the offence caused to any person.</p> <p>The provisions of this Regulation have been considered in the ESMPs.</p>
	Factories and Works Act (Chapter 14:08)	<p>This Act provides for the registration and control of factories, the regulation of conditions of work in factories, supervision of the use of machinery and precautions against accidental injury to persons employed on structural work.</p> <p>The provisions of this Act have been considered in the ESMPs with respect to the management of occupational health and safety of workers.</p>
Health	Factories and Works (Registration and Control of Factories) Regulations, 1976 of the Factories and Works Act	<p>These regulations provide for the registration and control of factories and provide occupational requirements associated design for factories.</p> <p>The provisions of this Act have been considered in the ESMPs with respect to the management of occupational health and safety of workers.</p>

Aspect	Legislation, Standard and/or Guideline Document	Applicability to the Batoka Gorge Hydro- Electric Scheme ESMP
	Public Health Act (Chapter 15:09)	<p>The ESMPs include measures such as the obligation to:</p> <ul style="list-style-type: none"> • Notify the health authorities of an infectious disease and/ or any formidable epidemic disease outbreak among on-site residents. • Ensure that persons involved with the handling of food do not suffer from known infectious diseases. • Ensure that residences where persons suffering from an infectious disease are efficiently disinfected before allowing access thereto. • Ensure that all food made available on-site is prepared and kept in a sanitary manner.
	Plant Pests and Diseases Act of 1959 (Chapter 19:08)	The ESMPs include steps necessary for prevention of the spread of pests.
	Pneumoconiosis Act (Chapter 15:08)	<p>This Act provides for the control and administration of persons employed in dusty occupations; and to provide for matters incidental to or connected with the foregoing. Part V of the Act requires that workers employed in dusty occupations have a current medical certificate. Part VI of this Act requires registration of employees working in dusty occupations in Zimbabwe. This register needs to include the date of engagement; the date of discharge; the nature of the worker's duties; the wages and allowances paid to the worker from time to time; the date of the last medical examination performed under this Act; the number and date of expiry of the current certificate. Part VI includes general provisions relating to worker benefits.</p> <p>The provisions of this Act have been considered in the ESMPs with respect to the management of occupational health and safety of workers.</p>

Aspect	Legislation, Standard and/or Guideline Document	Applicability to the Batoka Gorge Hydro- Electric Scheme ESMP
	Mining (Management & Safety) Regulations (S.I 109 of 1990) of the Mines and Minerals Act 1961	<p>The regulation provides an interpretation of mining to be (amongst others), the extracting of any mineral by any mode or method. Part II and II of the regulation provide conditions for the protection of mines and safety requirements for mines.</p> <p>The provisions of this Regulation have been considered in the ESMPs.</p>
	Mining (Health & Sanitation) Regulations (S.I. 185 of 1995) of the Mines and Minerals Act 1961	<p>Part I of this Regulation provides general health and sanitation requirements for mines in Zimbabwe, including (amongst others) the disposal of refuse; provisions for latrines; medical care and treatment of employees; and sanitation provisions. Part II of the Regulation includes (amongst others) provisions for accommodation of employees and other health aspects for employees.</p> <p>The provisions of this Regulation have been considered in the ESMPs.</p>
Road and Traffic	Road Motor Transportation Act of 1997	<p>The proposed Batoka Dam Project will require the transport of materials and machinery into the Project Area. Part III (Section 7 to 16) of the Road Motor Transportation Act details the requirements for goods vehicles on all roads and that these vehicles/drivers need to hold an operator's license. The operator's license application needs to be assigned for a specific route. Part IV of the Act provides the requirements for the operation of foreign vehicles on Zimbabwean roads. Requirements include the provision of a foreign license. Part V includes the provisions for the inspection of vehicles and the issuance of a certificate of fitness for vehicles.</p> <p>The provisions of this Act have been considered in the ESMPs.</p>

Aspect	Legislation, Standard and/or Guideline Document	Applicability to the Batoka Gorge Hydro- Electric Scheme ESMP
	Road Traffic Act (Chapter 13:11)	<p>Part II of this Act includes the provisions for the licensing of drivers of motor vehicles and the requirements for licenses (age limits, medical examinations, etc.). The Act stipulates that no person shall drive a motor vehicle on a road unless he is the holder of a valid licence issued to him in respect of motor vehicles of the class concerned, and complies with the conditions, if any, subject to which the licence was issued. Section 7 of the Act provides the minimum and maximum age limits associated with driving of vehicles on roads.</p> <p>Part III makes provision for the issuing of international driving permits. Section 17 states that any person who is an ordinarily resident in Zimbabwe; and the holder of a driver's licence or foreign drivers licence and who wishes to drive a motor vehicle outside Zimbabwe, must apply for an international driving permit.</p> <p>Part IV through to V (and VA) includes the provisions for motor vehicle insurance against third party. Part VI includes the provisions of traffic signs and police directions and the requirements around conformance.</p> <p>The provisions of this Act have been considered in the ESMPs.</p>
Immigration	Immigration Act (Chapter 4:02)	<p>Part III of this Act includes provisions for the entry of persons to Zimbabwe (<i>viz.</i> compliance with the directions of immigration officers, travel document requirements, entry refusals, etc.). Part V of the Act includes the provisions for departure from Zimbabwe.</p> <p>These provisions have been considered in the ESMPs.</p>
Access Control	Protected Place and Areas Act (Chapter 11:12)	<p>This Act includes the provisions for the control of entry of persons into certain places, for the protection of the premises. The control of access to work areas associated with the BGHES will be undertaken in accordance with the provisions/requirements in this Act.</p>

Aspect	Legislation, Standard and/or Guideline Document	Applicability to the Batoka Gorge Hydro- Electric Scheme ESMP
Cultural and Heritage	National Museums and Monuments Act (Chapter 25:11)	<p>Makes provision for the preservation of ancient, historical and natural monuments, relics and other objects of historical or scientific value or interest. Section 21 of the Act requires that the appropriate board be notified of any ancient monument or relic. Moreover, Section 24 states that no person may excavate any ancient monument or national monument without obtaining written permission from the appropriate Board.</p> <p>The ESMPs include a chance find procedure, which requires the notification of the Trustees of the National Museums and Monuments (“the Board”) upon discovery of any ancient monument or relic, and that no excavation, alteration, or removal of monuments takes place without written consent of the Board.</p>
Employment	<p>Labour Act (Chapter 28:01) as amended by Labour Act (Chapter 28:01) amended 2006 and the Labour Amendment Act (Act 7 of 2005)</p> <p>Indigenisation and Economic Empowerment Act [Chapter 14:33]</p>	<p>An Act to declare and define the fundamental rights of employees. Part II (Sections 4 to 7) provides the fundamental rights of employees, including entitlement to be a member of a trade union, protection against discrimination, the right to fair labour standards and the right to a democratic workplace.</p> <p>Part III of the Act provides provisions safeguarding employees to unfair labour practices and Part IV provides the general conditions of employment (<i>viz.</i> dismissal, retrenchment, wages, sick leave, death, maternity leave etc.).</p> <p>The ESMPs make provision for the rights of employees.</p> <p>Indigenous Zimbabweans can be defined as any person who, before the 18th April, 1980, was disadvantaged by unfair discrimination on the grounds of his or her race, and any descendant of such person, and includes any company, association, syndicate or partnership of which indigenous Zimbabweans form the majority of the members or hold the controlling interest. Indigenisation is a deliberate involvement of indigenous Zimbabweans in the economic activities of the country, to which hitherto they had no access, so as to ensure the equitable ownership of the nation’s resources.</p> <p>The BGHES will need to subscribe to the requirements of this Act. Requirements included in this Act have been considered in the ESMPs.</p>

Aspect	Legislation, Standard and/or Guideline Document	Applicability to the Batoka Gorge Hydro- Electric Scheme ESMP
Land issues	Communal Land Act (Chapter 20:04)	The ESMPs recognise communal land including water use rights and makes provision for due compensation to be given to affected parties.
	Rural District Councils Act of 1989 (Chapter 29:13)	The ESMPs include the obligation to adhere to the By-laws developed by Rural District Councils.
	Regional Town and Country Planning Act (Chapter 29:12)	The ESMPs include mitigation measures to manage the impact upon any land, which is designated as a park, wildlife and/ or forest lands.
	Traditional Leaders Act (Chapter 29:17)	The ESMPs have considered whether any traditional communities will be impacted by project related activities and the roles of these traditional leaders have been acknowledged through the consultation process.
	Rural Land Act (Chapter 20:18)	The ESMPs include provisions for development and implementation of a RAP, which should take into account the provisions of this Act.
	Rural Land Occupiers (Chapter 20:26) (Protection from Eviction) Act of 2002	
Energy	Electricity Act (Chapter 13:19)	This Act includes licensing provisions relating to the generation, transmission, distribution and supply of electricity. The licensing process is beyond the scope of the ESMPs.
	Energy Regulatory Act (Chapter 13:23)	This Act includes licensing provisions relating to the generation, transmission, distribution and supply of electricity. The licensing process is beyond the scope of the ESMPs.
Mining	Mines and Minerals Act 1961 (Chapter 21:05)	The ESMPs include measures associated with quarrying that are in line with the requirements of this Act. Please note that such activities will require licenses; however, the associated process is beyond the scope of the ESMPs.

Aspect	Legislation, Standard and/or Guideline Document	Applicability to the Batoka Gorge Hydro- Electric Scheme ESMP
	Environmental Management (Environmental Impact Assessments and Ecosystems Protection) Regulations (S.I. No. 7 of 2007) of the Environmental Management Act of 2002	The Environmental and Social Impact Assessment should consider the potential extraction, possession, transportation of sand and clay deposits; and the potential for activities to result in veld fires or the degradation of wetlands and/ or public streams. The Environmental and Social Management Plan needs to include provisions to manage impact related hereto. Please note that the extraction, possession, transportation of sand and clay deposits for commercial purposes will require a license. The licensing process is beyond the scope of the ESMPs.
Tourism	Tourism Act (Chapter 14:20)	The ESMPs include measures for the management of impacts to the tourism industry as far as is reasonably possible.

3.3 INTERNATIONAL GUIDELINES AND STANDARDS APPLICABLE TO THIS ESMP

Table 3.3 International Guidelines and Standards Applicable to this ESMP

Aspect	Legislation, Standard and/or Guideline Document	Applicability to the Batoka Gorge Hydro- Electric Scheme ESMP
WORLD BANK GROUP ENVIRONMENTAL AND SOCIAL SAFEGUARD POLICIES		
General Environmental Management	ESS1 Assessment and Management of Environmental and Social Risks and Impacts	This ESS amongst other requirements requires that environmental assessments prevent, minimise, mitigate, or compensate for adverse environmental impacts and enhance positive impacts, and that it must include a process of mitigating and managing adverse environmental impacts throughout project implementation. The ESMPs have been prepared to cover the activities associated with the BGHES. The purpose of the ESMPs are to outline appropriate management strategies and actions in order to meet acceptable levels of environmental and social performance for the proposed Project.

Aspect	Legislation, Standard and/or Guideline Document	Applicability to the Batoka Gorge Hydro- Electric Scheme ESMP
Resettlement	ESS5: Land Acquisition, Restrictions on Land Use and Involuntary Resettlement	<p>Triggered in situations involving involuntary taking of land and involuntary restrictions of access to legally designated parks and protected areas. The policy aims to avoid involuntary resettlement to the extent feasible, or to minimise and mitigate its adverse social and economic impacts.</p> <p>The policy also promotes participation of displaced people in resettlement planning and implementation, and its key economic objective is to assist displaced persons in their efforts to improve or at least restore their incomes and standards of living after displacement. The policy also prescribes compensation and other resettlement measures to achieve its objectives and requires that borrowers prepare adequate resettlement planning instruments prior to Bank appraisal of proposed projects.</p> <p>The ESMPs include actions necessary to satisfy resettlement requirements. Such actions will include the drafting of RAPs to guide the entire resettlement process.</p>
Cultural Heritage	ESS8: Cultural Heritage	<p>Addresses physical cultural resources, which are defined as movable or immovable objects, sites, structures, groups of structures, and natural features and landscapes that have archaeological, paleontological, historical, architectural, religious, aesthetic, or other cultural significance. Physical cultural resources may be located in urban or rural settings, and may be above or below ground, or under water. Their cultural interest may be at the local, provincial or national level, or within the international community. Any project involving significant excavations, demolition, movement of earth, flooding, or other environmental changes are to take cognisance of this Standard in the EA.</p> <p>This ESS has been considered in the ESMPs.</p>

Aspect	Legislation, Standard and/or Guideline Document	Applicability to the Batoka Gorge Hydro- Electric Scheme ESMP
Biodiversity	ESS6: Biodiversity Conservation and Sustainable Management of Living Natural Resources	<p>Recognizes that protection and conservation of biodiversity and sustainably managing living natural resources are fundamental to sustainable development and it recognizes the importance of maintaining core ecological functions of habitats, including forests, and the biodiversity they support. ESS6 also addresses sustainable management of primary production and harvesting of living natural resources, and recognizes the need to consider the livelihood of project-affected parties, including Indigenous Peoples, who's access to, or use of, biodiversity or living natural resources may be affected by a project.</p> <p>The ESIA's have considered all protected area and areas of ecological significance. The ESMPs include provisions on how to conduct activities in a manner that will least impact upon such areas as far as is reasonably possible.</p>
Dam Safety	World Bank Group Operational Policies – Operational Procedure (OP) 4.37: Safety of Dams	<p>This OP requires that experienced and competent professionals design and supervise construction, and that the borrower adopts and implements dam safety measures through the project cycle.</p> <p>Aspects of dam safety have been considered in the ESMPs.</p>
International Waterways	World Bank Group Operational Policies – Operational Procedure (OP) 7.50: Projects on International Waterways	<p>This OP applies to any river or body of surface water that flows through two or more states, whether these states are World Bank members or not.</p> <p>OP 7.50 is triggered by the BGHES and according to the ZRA notification has been made in accordance with provisions of Southern African Development Community (SADC) Protocol / Zambezi Watercourse Commission (ZAMCOM) Agreement and meeting the requirements of OP 7.50.</p>
INTERNATIONAL FINANCE CORPORATION (IFC) PERFORMANCE STANDARDS AND GUIDELINES		
Management of Social and Environmental Risks	Performance Standard (PS) 1 - Assessment and Management of Environmental and Social Risks and Impacts	<p>This PS underscores the importance of managing social and environmental performance throughout the life of a project (any business activity that is subject to assessment and management).</p> <p>The ESMPs have been prepared to cover the activities associated with the BGHES. The purpose of the ESMPs are to outline appropriate management strategies and actions in order to meet acceptable levels of environmental and social performance for the proposed Project.</p>

Aspect	Legislation, Standard and/or Guideline Document	Applicability to the Batoka Gorge Hydro- Electric Scheme ESMP
Worker Health and Safety	Performance Standard (PS) 2 - Labour and Working Conditions	<p>This PS recognizes that the pursuit of economic growth through employment creation and income generation should be accompanied by protection of the fundamental rights of workers.</p> <p>This PS has been considered in the ESMPs.</p>
	IFC General EHS Guideline 2. Occupational Health and Safety	<p>Provides guidelines on occupational health and safety related matters including:</p> <ul style="list-style-type: none"> • General Facility Design and Operation • Communication and Training • Physical Hazards • Chemical Hazards • Biological Hazards • Radiological Hazards • Personal Protective Equipment (PPE) • Special Hazard Environments • Monitoring <p>These guidelines have been considered in the ESMPs.</p>
	IFC General EHS Guidelines 4. Construction and Decommissioning	<p>Provides a guideline (4.1) on occupational health and safety matters related to construction and decommissioning activities. This has been considered in the ESMPs.</p>
Pollution Prevention	Performance Standard (PS) 3 - Resource Efficiency and Pollution Prevention Performance Standard	<p>This PS recognizes that increased economic activity and urbanization often generate increased levels of pollution to air, water, and land, and consume finite resources in a manner that may threaten people and the environment at the local, regional, and global levels.</p> <p>The provisions included in this PS have been considered in the ESMPs.</p>

Aspect	Legislation, Standard and/or Guideline Document	Applicability to the Batoka Gorge Hydro- Electric Scheme ESMP
	IFC General EHS Guideline 1. Environmental	<p>Provides guidelines on environmental conservation matters including:</p> <ul style="list-style-type: none"> • Air Emissions and Ambient Air Quality • Energy Conservation • Wastewater and Ambient Water Quality • Water Conservation • Hazardous Materials Management • Waste Management • Noise • Contaminated Land <p>These guidelines have been considered where relevant in the ESMPs.</p>
Community Health and Safety	Performance Standard (PS) 4 - Community Health, Safety and Security	<p>This PS recognizes that project activities, equipment, and infrastructure often bring benefits to communities including employment, services, and opportunities for economic development.</p> <p>The provisions included in this PS have been considered in the ESMPs.</p>
	IFC General EHS Guideline 3. Community Health and Safety	<p>Provides guidelines on community health and safety matters including:</p> <ul style="list-style-type: none"> • Water Quality and Availability • Structural Safety of Project Infrastructure • Life and Fire Safety (L&FS) • Traffic Safety • Transport of Hazardous Materials • Disease Prevention • Emergency Preparedness and Response <p>These EHS guidelines address aspects of project activities taking place outside of the traditional project boundaries and deal with communal issues (amongst others) around water quality and availability, traffic safety, transport of hazardous chemicals, disease prevention and emergency preparedness and response.</p> <p>These guidelines have been considered where relevant in the ESMPs.</p>

Aspect	Legislation, Standard and/or Guideline Document	Applicability to the Batoka Gorge Hydro- Electric Scheme ESMP
Air Quality	IFC Environmental, Health and Safety (EHS) Guidelines - 1.1 Environmental Air Emissions and Ambient Air Quality	<p>Includes the general principles of assessing impacts to air quality. In addition to the air quality standards set out, emission limits and guidelines for specific technologies and operations are also specified.</p> <p>The guidelines included in this EHS Guideline have been considered in the ESMPs.</p>
Water	IFC Environmental, Health and Safety (EHS) Guidelines - 1.3 Wastewater and Ambient Water Quality	<p>This EHS guideline specifies that discharges should not result in contaminant concentrations in excess of local ambient water quality criteria or, in the absence of local criteria, other sources of ambient water quality.</p> <p>Water quality management measures have been provided in the ESMPs.</p>
Noise	IFC Environmental, Health and Safety (EHS) Guidelines - 1.7 Noise	<p>This is an internationally recognised guideline document containing information for the assessment and management of noise. It also presents noise level criterion values applicable to sites such as the proposed Project. The guidelines make reference to noise from facilities and stationary noise sources, and are commonly applied as design standards for industrial facilities, and whilst this may imply they relate to some threshold of noise effects in a general sense, the IFC has indicated that they are not directly applicable to transport or mobile noise sources. Measurements are to be taken at noise receptors located outside the project property boundary.</p> <p>The guidelines included in this EHS Guideline have been considered in the ESMPs.</p>

Aspect	Legislation, Standard and/or Guideline Document	Applicability to the Batoka Gorge Hydro- Electric Scheme ESMP
Resettlement	Performance Standard (PS) 5 - Land Acquisition and Involuntary Resettlement outlines that involuntary resettlement refers both to physical displacement (relocation or loss of shelter) and to economic displacement (loss of assets or access to assets that leads to loss of income sources or means of livelihood) as a result of project-related land acquisition	<p>The stated purposes of this standard are:</p> <ul style="list-style-type: none"> • To avoid, and when avoidance is not possible, minimize displacement by exploring alternative project designs. • To avoid forced eviction. • To anticipate and avoid, or where avoidance is not possible, minimize adverse social and economic impacts from land acquisition or restrictions on land use by (i) providing compensation for loss of assets at replacement cost⁴ and (ii) ensuring that resettlement activities are implemented with appropriate disclosure of information, consultation, and the informed participation of those affected. • To improve, or restore, the livelihoods and standards of living of displaced persons. • To improve living conditions among physically displaced persons through the provision of adequate housing with security of tenure at resettlement sites. <p>The ESMPs recognize the need for Project specific RAP(s) to address resettlement mitigation.</p>
Biodiversity Conservation	Performance Standard (PS) 6 - Biodiversity Conservation and Sustainable Management of Living Natural Resources	<p>This PS recognizes that protecting and conserving biodiversity (the variety of life in all its forms, including genetic, species and ecosystem diversity) and its ability to change and evolve, is fundamental to sustainable development.</p> <p>The provisions included in this PS have been considered in the ESMPs.</p>

Aspect	Legislation, Standard and/or Guideline Document	Applicability to the Batoka Gorge Hydro- Electric Scheme ESMP
Indigenous People	<p>Performance Standard (PS) 7 Indigenous Peoples recognizes that Indigenous Peoples, as social groups with identities that are distinct from dominant groups in national societies, are often among the most marginalized and vulnerable segments of the population.</p>	<p>This Performance Standard applies to communities or groups of Indigenous Peoples who maintain a collective attachment, i.e., whose identity as a group or community is linked to distinct habitats or ancestral territories and the natural resources therein. It may also apply to communities or groups that have lost collective attachment to distinct habitats or ancestral territories in the project area, occurring within the concerned group members' lifetime, because of forced severance, conflict, government resettlement programs, dispossession of their lands, natural disasters, or incorporation of such territories into an urban area.</p> <p>Indigenous people may be impacted on as a result of the project if they are likely to be affected by physical or economic displacement. This will be ascertained further upon the commencement of the RAP.</p> <p>Stakeholder consultation to date has been sensitive to the vulnerability of the affected communities and the requirements of PS7 will be carried forward into the RAP(s).</p> <p>The IFC Guide to Human Rights Impact Assessment and Management will also require consideration if there is an impact on Indigenous People.</p>
Heritage	<p>Performance Standard (PS) 8 - Cultural Heritage</p>	<p>This PS recognises the importance of cultural heritage for current and future generations.</p> <p>The ESIA undertaken included a specialist cultural heritage surveys in Zambia and Zimbabwe. The ESMPs include actions necessary to ensure the safeguarding of all cultural heritage potentially impacted by project activities.</p>

Aspect	Legislation, Standard and/or Guideline Document	Applicability to the Batoka Gorge Hydro- Electric Scheme ESMP
AFRICAN DEVELOPMENT BANK GROUP'S INTEGRATED SAFEGUARD SYSTEM AND OPERATIONAL SAFEGUARDS		
Environmental and Social Assessment	African Development Bank Operational Safeguard (OS) 1 – Environmental and Social Assessment	<p>This OS provides mainstream environmental and social considerations. An objective of this OS is to avoid or, if avoidance is not possible, minimise, mitigate and compensate for adverse impacts on the environment and on affected communities.</p> <p>The ESMPs have been prepared to cover the activities associated with the BGHES and includes measures associated with post-construction revegetation and construction. The purpose of the ESMPs are to outline appropriate management strategies and actions in order to meet acceptable levels of environmental and social performance for the proposed Project.</p>
Resettlement	African Development Bank Operational Safeguard (OS) 2 – Involuntary Resettlement: Land Acquisition, Population Displacement and Compensation	<p>It relates to Bank-financed projects that cause the involuntary resettlement of people. It seeks to ensure that when people must be displaced they are treated fairly, equitably, and in a socially and culturally sensitive manner; that they receive compensation and resettlement assistance so that their standards of living, income-earning capacity, production levels and overall means of livelihood are improved; and that they share in the benefits of the project that involves their resettlement.</p> <p>The ESMPs recognize the need for Project specific RAP(s) to address resettlement mitigation.</p>
Biodiversity	African Development Bank Operational Safeguard (OS) 3 – Biodiversity, Renewable Resources and Ecosystem Services	<p>This OS outlines the requirements for borrowers or clients to (i) identify and implement opportunities to conserve and sustainably use biodiversity and natural habitats, and (ii) observe, implement, and respond to requirements for the conservation and sustainable management of priority ecosystem services.</p> <p>The protection of biodiversity has been considered in the ESMPs.</p>
Pollution Prevention and Control	African Development Bank Operational Safeguard (OS) 4 – Pollution Prevention and Control, Hazardous Materials and Resource Efficiency	<p>This OS outlines the main pollution prevention and control requirements for borrowers or clients to achieve high-quality environmental performance, and efficient and sustainable use of natural resources, over the life of a project. More specifically, the OS outlines requirements for borrowers to reduce pollutants resulting from the project – including hazardous and non-hazardous waste – so that they do not pose harmful risks to human health and the environment.</p> <p>The provisions included in this OS have been considered in the ESMPs.</p>

Aspect	Legislation, Standard and/or Guideline Document	Applicability to the Batoka Gorge Hydro- Electric Scheme ESMP
Labour Health and Safety	African Development Bank Operational Safeguard (OS) 5 – Labour Conditions, Health and Safety	<p>This OS outlines the main requirements for borrowers or clients to protect the rights of workers and provide for their basic needs.</p> <p>The provisions included in this OS have been considered in the ESMPs.</p>
OTHER		
	<p>The Southern African Power Pool (SAPP) Environmental and Social Impact Assessment Guidelines for Hydroelectric Projects and Transmission Infrastructure in the SAPP region</p> <hr/> <p>International Hydropower Association’s (IHA) Sustainability Guidelines (SGs)</p>	<p>The guidelines provide further guidance on the ESIA process to be undertaken, specifically regarding the components and format of an ESIA, and the stakeholder engagement required to be undertaken.</p> <p>These guidelines have been considered in the ESMPs.</p> <hr/> <p>The IHA Sustainability Guidelines promote greater consideration of environment, social, and economic sustainability in the assessment of new hydropower projects to assist with the evaluation and management of often competing environmental, social and economic issues that arise in the assessment, operation and management of hydropower projects. The Sustainability Guidelines suggest a number of environmental and social strategies to optimise environmental and social outcomes for Hydropower Schemes.</p> <p>These guidelines have been considered in the ESMPs.</p>

3.4 PROJECT STANDARDS

3.4.1 Introduction

Where applicable, the national legislative requirements for Zambia and Zimbabwe & international guidelines and standards are considered in this ESMP; however, of particular importance to this ESMP are the Project standards for water quality; air quality and noise. These are discussed in more detail below.

3.4.2 Water Quality

Zambia

IFC EHS Guideline 1.3 (refer to *Section 3.3*) specifies that discharges should not result in contaminant concentrations in excess of local ambient water quality criteria or, in the absence of local criteria, other sources of ambient water quality. Receiving water use and assimilative capacity, taking other sources of discharges to the receiving water into consideration, should also influence the acceptable pollution loadings and effluent discharge quality.

As Zambia has water quality criteria / standards for effluent discharge into environment, these have been used.

Sections 23, 34 and 96 of the Zambian Water Pollution Control (Effluent and Waste Water) Regulations (S.I. No. 133 of 1996) states that all permitted effluent discharges into the natural environment will need to conform to the conditions and standards for chemical and physical parameters contained in *Table 3.4*.

Table 3.4 Standards (Limits) for Effluent Discharge into the Natural Environment

No.	Parameter	Concentration (as mg/l)	Note
Physical Parameters			
1	Temperature (at point of entry)	40 °C	-
2	Colour	20 hazen units	-
3	Odour and taste	-	Must not cause any deterioration in taste or odour as compared with natural state.
4	Turbidity (Nephelometer turbidity units scale)	15	-
5	Total suspended solids	100	Must not cause formation of sludge or scum in receiving water.
6	Settleable matter	0.5	Sedimentation in two hours (Imhoff funnel). Must not cause formation of sludge in receiving water.
7	Total dissolved solids	3,000	Evaporation < 105 °C and gravimetric method. The TDS of wastewater must not adversely affect surface.
8	Conductivity	4,300 US/electronic method	-

No.	Parameter	Concentration (as mg/l)	Note
Bacteriological			
9	Total coliform/100 ml	25,000	Membrane filtration method
10	Faecal coliform/100 ml	5,000	
11	Algae/100 ml	1,000 cells	-
Chemical			
12	pH	6.0 - 9.0	0-14 scale (electrometric method)
13	Dissolved oxygen	5	Using modified winkler method and membrane electrode method. Note, after complete mixing extreme temperature may result in lower values.
14	Chemical oxygen demand (COD)	-	-
15	Biochemical oxygen demand (BOD)	50	Using modified winkler method and membrane electrode method. Mean value over a 24-hour period.
16	Nitrates NO ₃ as nitrogen	> 50 in water courses and > 20 in lakes	Using a spectrometric method and electrometric method. The nitrates burden must be reduced as far as possible according to circumstances.
17	Nitrite NO ₂ as nitrogen	2.0	-
18	Organic nitrogen	5.0	The % of nutrient elements for degradation of BOD should be 0.4-1% for phosphorous. Different for processes for using algae.
19	Ammonia and ammonium	10	Using the nesslerization method and electrometric method. The concentration is dependent on temperature, pH and salinity.
20	Cyanides	0.2	Using the spectrophotometric method.
21	Phosphorous (total) (P ₀₄ as P/L)	1.0 to 6.0	Using the colorimetric method. In the catchment area of lakes: 1.0 mg/L; located outside the catchment area: reduce the load of P as low as possible (P ₀₄ =6 mg/L)
22	Sulphates	1,500	Using the turbidimetric method.
23	Sulfite	1.0	Using the iodometric method. Note that presence of Oxygen Changes S ₀₃ to S ₀₄ .
24	Sulphide	0.1	Using the iodometric and electrometric method. Note that concentration is dependent on temperature, pH and dissolved O ₂ .
25	Chlorides (silver nitrates and mercuric nitrate)	800	-
26	Active chloride	0.5	Using the iodometric method.
27	Active bromine	0.1	-
28	Fluorides	2.0	Using the electrometric method and colorimetric method with distillation.
Metals			
29	Aluminium compounds	2.5	Using the atomic absorption method.
30	Antimony	0.05	
31	Arsenic compounds	0.5	
32	Barium compounds (water soluble concentration)	0.5	
33	Beryllium salts and compounds	0.5	
34	Boron compounds	0.5	Using the spectro-photometric method and curcumin method.
35	Cadmium compounds	0.5	Using the atomic absorption method.

No.	Parameter	Concentration (as mg/l)	Note
36	Chromium Hexavalent, trivalent	0.1	
37	Cobalt compounds	1.0	
38	Copper compounds	1.5	
39	Iron compounds	2.0	
40	Lead compounds	0.5	
41	Magnesium	500	Using the atomic absorption method and flame photometric method.
42	Manganese	1.0	Using the atomic absorption method.
43	Mercury	0.002	
44	Molybdenum	5.0	
45	Nickel	0.5	
46	Selenium	0.02	
47	Silver	0.1	
48	Thallium	0.5	
49	Tin compounds	2.0	
50	Vanadium compounds	1.0	
51	Zinc compounds	10.0	
Organics			
52	Total hydrocarbons	10.0	Using the chromatographic method.
53	Oils (mineral and crude)	5.0	Using the chromatographic method and gravimetric method.
54	Phenols (steam distillable)	0.2	Using the colorimetric method.
	Phenols (non-steam distilled)	0.05	
55	Fats and saponifiable oils	20.0	Gravimetric method and chromatographic method
56	Detergents (atomic)	2.0	Using the atomic absorption spectrophotometric method. Detergents should contain at least biodegradable compounds.
57	Pesticides and PCB's (total)	0.5	Using the chromatographic method.
58	Trihaloforms	0.5	
Radioactive Materials			
	Radioactive materials as specified by the international atomic energy agency	No discharge permitted	-

Zimbabwe

Sections 57 to 59 of the Environmental Management Act (Chapter 20:27), (No. 13 of 2002) states that environmental quality standards need to be established for water pollution. No reference to water quality standards could be sourced and it appears as if these do not yet exist.

The IFC EHS Guideline 1.3 states that in the absence of local ambient water quality criteria, other sources of ambient water quality will apply. As Zambia has water quality criteria / standards for effluent discharge into environment, these will be adopted as the effluent discharge standards for the BGHES in Zimbabwe.

3.4.3

Air Quality

Zambia

The IFC recommend that the air quality guidelines as set out by the World Health Organisation (WHO) be utilised in such an assessment. The WHO standards are divided into a number of stages, which have interim targets and a final guideline target. The WHO guidelines are recognised to be particularly conservative, as they make no consideration of the economic burden of achieving the stipulated guidelines. The WHO final guideline target is aspirational, and as such, this target should be progressively worked towards.

As such, in the majority of cases, the IFC EHS General Guidelines are substantially more stringent than the Zambian Air Quality Standards.

On the basis of the above, and using a pragmatic approach, the Zambian Air Quality Standards have been used. Section 37, 46 and 96 of Air Pollution Control (Licensing and Emission Standards) Regulations (S.I. No. 141 of 1996) states that industrial or business activities undertaken by an operator shall be within the limits presented in *Table 3.5*. These limits strive to safeguard the general health, safety or welfare of persons, animal life, plant life or property affected by the works, industrial or business activities.

Table 3.5 *Table of Guideline Limits for Ambient Air at Source*

Parameter	Reference Time		Guideline Limit
Sulphur Dioxide (SO ₂)	10 minutes		500 µg/m ³
	1 hour		350 µg/m ³
Sulphur Dioxide (SO ₂) in combination with total suspended particles (TSP)* ¹ and (PM ₁₀)	SO ₂	24 hours	125 µg/m ³
		6 months	50 µg/m ³
	TSP	24 hours	120 µg/m ³
		6 months	50 µg/m ³
	PM ₁₀	24 hours	70 µg/m ³
	Respirable Particulate Matter (PM ₁₀)* ²	PM ₁₀	24 hours
Oxides of Nitrogen (NO _x)	1 hour		400 µg/m ³
	24 hours		150 µg/m ³
Carbon Monoxide (CO)	15 minutes		100 µg/m ³
	30 minutes		60 µg/m ³
	1 hour		30 µg/m ³
	8 hours		10 µg/m ³
Ambient Lead (Pb)	3 months		1.5 µg/m ³
	12 months		1.0 µg/m ³
Dust Fall	30 days		7.5 tonnes /km ²

*1. Total suspended particles (TSP) are particles with diameter less than 45 micrometers (mm).

*2. Respirable particles (PM₁₀) are particles with diameter less than 10 micrometers (mm). These can penetrate to the ancilliary regions of the deep lung.

Note: Reference time are the 98th percentile averaging times.

Zimbabwe

The Zimbabwean Standards and Enforcement Committee of the EMA are in the process of drafting Air Quality and Emission Standards (draft number EN 005 - D977/2) of the Environmental Management Act of 2002. These have not been enacted.

In the absence of specific national air quality standards, the IFC recommended air quality guidelines as set out by the World Health Organisation (WHO) will be used. The WHO standards are divided into a number of stages, which have interim targets and a final guideline target (refer to Table 3.6).

Table 3.6 IFC / WHO Air Quality Guidelines at Source

IFC EHS General Guidelines		
Pollutant	Averaging period	Criterion ($\mu\text{g}/\text{m}^3$)
SO ₂	annual mean	40
SO ₂	24 hour maximum	125 (Interim target 1) 50 (Interim target 2) 20 (Guideline)
SO ₂	10 minute maximum	500 (Guideline)
NO ₂	annual mean	40 (Guideline)
NO ₂	1 hour maximum	200 (Guideline)
PM ₁₀	annual mean	70 (Interim target 1) 50 (Interim target 2) 30 (Interim target 3) 20 (Guideline)
PM ₁₀	24 hour maximum	150 (Interim target 1) 100 (Interim target 2) 75 (Interim target 3) 50 (Guideline)
PM _{2.5}	annual mean	35 (Interim target 1) 25 (Interim target 1) 15 (Interim target 3) 10 (Guideline)
PM _{2.5}	24 hour maximum	75 (Interim target 1) 50 (Interim target 2) 37.5 (Interim target 3) 25 (Guideline)

3.4.4

Noise

Zambia

Section 68 of Division 6 (Part IV) of the Zambian Environmental Management Act (No. 12 of 2011) states that no person shall emit noise in excess of the noise emission standards established. To ERM's knowledge, there are no noise standards yet; accordingly, the World Health Organisation, World Bank or donor country standards apply.

Accordingly, with reference to the IFC and World Bank Guidelines, noise emissions should not exceed the limits presented in *Table 3.7* at the nearest Noise Sensitive receptor (NSR) locations offsite. In addition to the absolute

values provided in *Table 3.7*, the IFC also requires that noise increase above existing (background) levels should not exceed 3 dB.

Table 3.7 *IFC Noise Level Guidelines*

Receptor	One Hour L _{Aeq} (dB(A))	
	Daytime (07:00 - 22:00)	Night (22:00 - 07:00)
Residential; institutional; educational	55	45
Industrial; commercial	70	70

L_{Aeq} = A-weighted equivalent sound levels over a measurement period, dB(A) = A-weighted decibel

Zimbabwe

Sections 79 to 81 in Part IX of the Environmental Management Act (Chapter 20:27) (No. 13 of 2002) provide requirements around noise management. More specifically, the Act mentions the need for standards to be established for the emissions of noise and vibration pollution. No reference to noise standards could be sourced and it appears as if these do not yet exist.

In the absence of specific national noise standards, the IFC and World Bank Guidelines standards included for Zambia will apply (refer to *Table 3.7*).

4.1 SCOPE

This *Chapter* details the required mitigation measures, and is prescriptive, identifying specific people or organisations to undertake specific tasks in order to ensure that impacts on the receiving biophysical and socio-economic environments are minimised during the pre-construction and construction works. This CESMP is applicable to all work activities associated with the following Project components during the pre-construction, site establishment and the construction phases:

- Dam wall and impoundment, including a spillway;
- Surface power houses, one on each side of the river; and
- Project townships (in both Zambia and Zimbabwe) and other ancillary infrastructure (such as quarries, spoils area and batching areas).

As mentioned in *Chapter 0*, separate CESMPs have been compiled for 1) Access Roads in Zambia and Zimbabwe; and 2) Transmission Lines in Zambia and Zimbabwe. For a holistic understanding of Project environmental and social management commitments for during the construction phase, this CESMP should be considered in conjunction with the remaining Project CESMPs.

This CESMP is a dynamic document implying that information gained during pre-construction, site establishment and the construction works including monitoring on the site could lead to changes in this CESMP.

4.2 ACTIVITIES TO BE UNDERTAKEN DURING THE CONSTRUCTION PHASE OF THE PROJECT

The following activities are proposed during the Construction Phase of the Project:

4.2.1 *Staff Township Development*

- Bulk earthworks
- Services for the staff townships to be secured
- Economic displacement compensation to be paid
- Fencing/security development
- Vegetation clearing
- Topsoil stockpiling
- Infrastructure development

4.2.2 *Site Establishment for the Dam Wall*

- Land to be secured
- Services for laydown area and construction area to be secured
- Vegetation clearing and topsoil stockpiling for the laydown area
- Fencing/security development
- Vegetation clearing and topsoil stockpiling for quarry areas
- Crushing of quarry materials
- Transportation of quarried materials
- Surface drainage
- Quarrying (for which a license will be required)

4.2.3 *Powerhouses*

- Vegetation/soil/rock clearing on footprint proposed for the powerhouse infrastructure
- Power waterway with intake, power tunnel, a surge shaft, vertical/horizontal underground penstocks and manifolds to be developed
- Powerhouses on river bank downstream to be constructed
- Step-up transformers to be installed
- Switchyards to be developed

4.2.4 *River Diversion*

- Development of diversion tunnel/s

4.2.5 *Dam Wall Development*

- Concrete batching for the wall and coffer dam development
- Development of coffer dams
- Foundations to be established for the dam wall
- Dam wall development including water outlet works and spillway
- Plunge pool development
- Management of exposed substrate

4.2.6 *Dam Inundation*

- Flooding of dam area
- Fauna search and rescue

4.2.7 *Permanent Staff Township Development*

- Bulk earthworks
- Services for the staff townships to be secured
- Fencing/security development
- Vegetation clearing
- Topsoil stockpiling
- Infrastructure development

4.2.8 *Unforeseen Events*

- Traffic incidents
- Dam wall failure
- Water contamination
- Flooding
- Release of hazardous substances

4.3 *POTENTIAL ENVIRONMENTAL AND SOCIAL IMPACTS*

The Project activities included in *Section 4.2* have the potential to result in the following environmental and social impacts:

Biophysical Impacts

- Impacts associated with greenhouse gas (GHG) emissions
- Impacts on air quality (elevations of airborne dust and particulate matter, PM₁₀ and PM_{2.5})
- Impacts on noise (noise emissions from Project construction activities)
- Impacts to water and soil resources as a result of construction pollution.
- Impacts associated with habitat loss and degradation
- Impacts to fauna
- Impacts associated with invasive alien plants
- Direct loss of critical habitat through filling of the reservoir and development infrastructure
- Habitat degradation resulting from altered flow regimes

Social Impacts

- Impacts associated with displacement (economic displacement of land-based livelihoods, fishing activities and downstream river users).
- Social benefits resulting from local employment opportunities, local procurement of goods and services and opportunities for community development.
- Impacts associated with unmet expectations.
- Impacts related to in-migration.
- Health and safety impacts (increased incidence of communicable diseases; increased incidence of malaria and other vector borne diseases; increased risk of traffic accidents; disturbance due to dust and noise; impact to community security; and worker health and safety)
- Changes to socio-cultural heritage and heritage resources due to destruction or disturbance to sites of heritage value and impacts to living cultural heritage.

A more detailed description of the above mentioned impacts is provided in the ESIA.

Any Method Statement required by the Engineer or the Environmental Specification (*Section 4.6*) shall be produced within such reasonable time as the Engineer shall specify or as required by the Specification. The Contractor shall not commence the activity until the Method Statement has been approved and shall, except in the case of emergency activities, allow a period of two weeks for approval of the Method Statement by the Engineer. Such approval shall not unreasonably be withheld.

The Engineer or SHEQ Manager may request a Method Statement for any activity they believe may impact on the environment. The Engineer in consultation with the SHEQ Manager may also require changes to a Method Statement if the proposal does not comply with the Specification or, if in the reasonable opinion of the Engineer, the proposal may result in, or carry a greater than reasonable risk of damage to the environment in excess of that permitted by the Specifications.

Approved Method Statements shall be readily available on the site and shall be communicated to all relevant personnel. The Contractor shall carry out the Works in accordance with the approved Method Statement. Approval of the Method Statement shall not absolve the Contractor from any of his obligations or responsibilities in terms of the Contract.

The following Method Statements shall be provided by the Contractor and submitted to the Engineer and SHEQ Manager at least ten working days before site establishment:

- **Site Establishment:** Detailing the location, layout and method of establishment of the staff townships and laydown areas (including all buildings, offices, lay down yards, vehicle wash areas, fuel storage areas, batching areas and other infrastructure required for the running of the Project).
- **Vegetation Clearing:** Detailing the method of vegetation clearing during site establishment and disposal procedure for cleared material.
- **Topsoil/Sub Soil Stockpiling:** Method of clearing topsoil/sub soil and location of topsoil/sub soil stockpiles including erosion protection.
- **Stormwater Management:** Stormwater is to be managed during the construction phase of the Project. The method statement should detail how this is proposed as well as erosion and sedimentation control measures.
- **Solid Waste Management:** Detail to be provided with regard to expected solid waste types, quantities, methods of recycling to be employed, monitoring and record keeping procedures, staff responsible for the oversight of waste management and recycling and frequency of collection

and disposal of the non-recycled component, as well as location of disposal sites.

- **Quarrying Activities**: Detail required with regard to size of quarries, volumes to be extracted, dust, noise and water management, details with regard to transportation of quarried materials.
- **Concrete Mixing and Batching**: Location, layout and preparation of cement/ concrete mixing areas, including the methods employed for the mixing of concrete and particularly the containment of runoff water, preferably by means of settlement chambers, from such areas and the method of transportation of concrete.
- **Access and Haul Roads**: Details, including a drawing, showing where and how the access points and routes will be located and managed, including traffic safety measures.
- **Hazardous Substances**: Details of any hazardous substances / materials to be used, together with the transport, storage, handling and disposal procedures for the substances.
- **Contaminated Water**: Methods of minimizing, controlling, collecting and disposing of contaminated water.
- **River Diversion**: Methods of minimizing impact on natural flow and controlling river diversion. Should include methods for minimizing sedimentation and pollution control.
- **Dam Inundation**: Details, including a drawing, showing where, when and how the dam will be inundated. The method of dam construction will need to be elaborated on. The method statement should include vegetation clearing and fauna search and rescue.
- **Environmental Incident Reporting**: Method and process to be followed in the event of an environmental incident on site.

In addition to those Method Statement mentioned above, the following Method Statements (as detailed in this CESMP) will need to be developed:

- Air Quality Management Method Statement
- Noise and Vibration Management Method Statement
- Blasting Management Method Statement
- Fire Safety Method Statement
- Hydrological Management Method Statement
- Water Resources Method Statement
- Erosion and Sediment Management Method Statement

- Environmental Awareness Training Method Statement

- Biodiversity Management Method Statement
- Animal Rescue Method Statement

- HIV/AIDS Management Method Statement
- Tuberculosis and Malaria Management Method Statement
- Occupational Health and Safety Method Statement
- Community Health and Safety Method Statement
- Traffic Management Method Statement
- Local Employment Method Statement
- Labour Force Management Method Statement
- Local Content Method Statement
- Contractor Audit and Supply Chain Management Method Statement
- Project Induced In-migration (PIIM) Management Method Statement
- Security Management Method Statement
- Cultural Heritage Method Statement

4.4.1 *Other Method Statements*

Other Method Statements required by the Engineer and SHEQ Manager during the course of construction are to be provided by the Contractor a minimum of fourteen working days prior to commencement of the works or activities to which they apply (these activities may not commence on site before these Method Statements have been approved, except in the case of emergency activities).

4.5 *DEVELOP EMERGENCY PREPAREDNESS PLAN*

A Dam Safety Plan (Volume 7, September 2019) has been developed by the Project Engineers (SP) for the BGHES. This is attached in *Annex C*. Part E of this Plan includes the Emergency Preparedness Plan (Framework Plan), which includes a description of the types of emergencies; how to identify emergencies; the actions to be taken during an emergency; preparedness and emergency response; and a dam break analysis. The Framework Plan commits to the development of a detailed Emergency Preparedness Plan for the Dam in compliance with the WB Guidelines (OP 4.37) not later than one year before the initial filling of the BGHES reservoir.

In addition to emergency planning for the dam, the Emergency Preparedness Plan will need to also cover all incidents presenting risks to public safety and the affected communities in proximity to other Project infrastructure / sites and the environment. The Plan should:

- Be applicable to all contractors and subcontractors as well as local communities;

- Consider access to health care, major incidences, exposure to hazardous materials, multiple casualty events, epidemics and pandemics; and

- Make provisions for awareness-raising activities and emergency response training to the communities that are considered to be at higher risk.

The Plan will also need to provide a detailed procedure should an emergency evacuation of the staff townships, permanent townships and Project site be ordered. As part of ZRA's and its contractor's emergency preparedness, they will be required to have trained personnel and emergency equipment in place in the event of any emergency and all site personnel, including contractors, are to be trained in the appropriate responses for fire and accident emergencies.

4.6

MANAGEMENT SPECIFICATIONS

Management specifications for the Pre-Construction and Construction Phase of the Project are presented in *Table 4.1*. These specifications address the following requirements:

- Aspect (i.e. – what is being managed)
- Activity generating impact;
- Mitigation/management action;
- Measure of effectiveness;
- Responsibility for implementing action;
- Frequency of management; and
- Reporting requirements.

Table 4.1 is separated into management actions for during the pre-construction phase and management actions for during the construction phase. *Table 4.1* includes the following management measures:

- **Physical Environmental Management:**
 - Air Quality Management
 - Noise and Vibration Management
 - Soils Management
 - Surface and Groundwater Management
 - Visual Management
- **Biodiversity Management**
- **Social Management:**
 - Cultural Heritage
 - Public Health and Safety
 - Occupational Health and Safety
 - Social
 - Stakeholder Engagement
- **General Environmental Management**
- **Training**

- **Wastewater Management**
- **Solid Waste Management**

Further to this, requirements for monitoring and performance assessment are detailed in *Chapter 5*.

The mitigation/management actions are presented on the basis of the current Project description and understanding of proposed Project activities. Given that the Project is currently in the pre-feasibility stage, it is envisaged that this CESMP will require updating following completion and approval of the ESIA's, prior to the commencement of construction activities on site and following the feasibility and detailed design phase of the Project. Regulatory authorities in Zimbabwe and Zambia will need to be notified of the updates as and when they occur together with their content.

4.7

TEMPORARY SITE CLOSURE

If the site is closed for a period exceeding one week, a checklist procedure will be carried out by the Contractor in consultation with the SHEQ Manager.

The Contractor is to check the site and report to the Engineer regarding the following:

Fuels / flammables / hazardous materials stored:

- Ensure fuel stores are as low in volume as possible;
- No leaks;
- Outlet secure / locked;
- Bund empty;
- Fire extinguisher serviced and accessible;
- Secure area from accidental damage, e.g. vehicle collision;
- Emergency and Management telephone numbers to be available and displayed; and
- Adequate ventilation.

Other:

- All trenches and manholes secured;
- Fencing and barriers in place;
- Notice boards applicable and secured;
- Security persons briefed and have facility for contact;
- Night hazards checked, e.g. reflectors, lighting, traffic signage;
- Fire hazards identified – local authority notified of any potential threats, e.g. large brush stockpiles, fuels etc.;
- Pipe stockpile wedged / secured;
- Scaffolds secure; and

- Inspection schedule and log by security or contracts staff.

The SHEQ Manager are to check and report to the Engineer regarding the following issues:

- Wind and dust mitigation in place, e.g. straw, brush packs, irrigation;
- Slopes and stockpiles at stable angle;
- Landscape areas watering schedules and supply secured;
- Fuels/hazardous substances stored secure;
- Cement and materials stores secured;
- Toilets empty and secured;
- Refuse bins empty and lids secured;
- Bunding clean and treated, e.g. Spill Sorb or Enretech #1 powder;
- Drip trays empty and secure; and
- Structures vulnerable to high winds secure.

The Contractor is to ensure that all temporary closure requirements are met before leaving the site.

4.8 *SITE CLEAN UP POST CONSTRUCTION*

4.8.1 *Site Clean Up*

The Contractor will ensure that all temporary structures, equipment, materials, waste and facilities used for construction work purposes are removed upon completion of the construction works. Site clean-up shall be to the satisfaction of the Engineer and the SHEQ Manager.

Where appropriate, the Contractor shall employ a suitably qualified person to rehabilitate areas damaged by activities associated with construction works during the course of the Project. The Contractor shall be responsible for rehabilitating areas identified by the SHEQ Manager and the Engineer, or recommended by the aforementioned qualified person. The Contractor's procedure for construction rehabilitation shall be approved by the SHEQ Manager and the Engineer and, where required, the District Authority's environmental representative.

Table 4.1 Pre-construction and Construction Management Specifications

Aspect	Activity	No.	Mitigation/Management Action	Measure of Effectiveness	Responsibility	Frequency	Reporting Requirements
Pre-construction Phase							
Greenhouse Gas Emissions	Salvage of fuel wood	1.	<p>A mitigation / management action for during the construction phase is to make destroyed trees available to communities as fuel wood or building resources (excluding vegetation in the area of inundation). This will ultimately reduce the release of GHG emissions associated with landuse change.</p> <p>Prior to the start of the construction phase, the ZRA will contract a GHG specialist to carry out a timber survey to estimate the amount of timber that can be recovered from areas that will be cleared during construction. Such a survey will allow the Project to quantitatively estimate the amount of GHG that will not be released through land use changes, and report on these results to regulators/relevant Project lenders.</p>	Timber survey and quantitative reporting of GHG emission savings.	Contractor	Prior to construction	Reporting of results to regulators / relevant Project lenders
Surface and Groundwater	Water permitting	2.	Appropriate Zambian and Zimbabwean government departments will be consulted to obtain water abstraction permits/licenses necessary for the successful construction of the BGHES.	All the necessary water permits in place	Contractor	Prior to construction	As per national water licensing requirements
	Water availability and vulnerability	3.	<p>Although not required at this moment in time, if groundwater abstraction is required, detailed studies will be conducted to assess water availability and vulnerability in areas where groundwater will be required. These studies will consider the sustainable yields of the aquifers and surface water bodies.</p> <p>The interaction of groundwater systems targeted by the Project and nearby surface water features (particularly to quantify the loss-gain relationship between them) is another important consideration that will be established. This will help establish a better water resources management for the Project and assist in providing a sustainable allocation of water.</p>	Detailed project planning designs	Contractor	Prior to construction	Pre-Construction compliance report
Protected areas	Design and planning: project townships	4.	Project townships will be placed outside of the boundaries of national parks and world heritage sites	Detailed project planning designs	Developer/Biodiversity Specialists	Prior to and throughout construction	Pre-Construction compliance report
	Design and planning: quarries and disposal areas	5.	<p>The siting of quarries and disposal areas will be such that -</p> <ul style="list-style-type: none"> • A 50 meter buffer around the rim of the Batoka Gorge (including the rim of side tributaries entering the Gorge) are avoided; and • Drainage lines will be avoided to the extent possible <p>Moreover, the location of disposal areas (as these are yet to be defined) will be sited such that critical and natural habitat areas are avoided to the extent possible. To the greatest extent possible disposal areas will be located in areas with a lower sensitivity - i.e. - low sensitivity natural habitat and modified habitat.</p>	Detailed project planning designs	Contractor	Prior to and throughout construction	Pre-Construction compliance report
	Destruction/damage to threatened and endemic flora	6.	Plants of conservation concern that are at risk of being lost due to construction activities will, where possible	Report on relocation indicating plant	Developer/Contractor/Botanical Specialist	Prior to construction and	Pre-Construction compliance report

Aspect	Activity	No.	Mitigation/Management Action	Measure of Effectiveness	Responsibility	Frequency	Reporting Requirements
Biodiversity, Habitat loss for fauna			and practical, be relocated to safe areas of similar habitat. A botanical specialist will conduct a preconstruction assessment covering the following activities once the precise areas of clearance are known: <ul style="list-style-type: none"> Identify and mark plants for translocation, Determine appropriate translocation procedures, equipment, labour and timing; and Identify suitable areas where plants can be translocated. 	species, and illustrating locations moved from, locations moved to. Effectiveness will be increased if surveys are conducted during the growing season.		site establishment	
	Dam and quarry design and planning: biodiversity management	7.	ZRA will develop and maintain a structured inventory of species that are present in the affected Project area. The species within this inventory will be classified into taxonomic groups and families, threatened status using the IUCN Red List and their perceived threat status within the Project area and surrounding areas.	Species inventory	Developer/Biodiversity Specialists	Prior to construction and site establishment	Pre-Construction compliance report
		8.	ZRA will engage the local Zimbabwe Wildlife Authorities to assess the risk of Problem Animal incidents for construction activities, personnel accommodation and community welfare, and explore ethical means of addressing these without loss of the animals.	Specialist report	Developer/Biodiversity Specialists	Prior to construction and site establishment	Pre-Construction compliance report
		9.	ZRA will appoint qualified ecologists to work with the relevant wildlife authorities to conduct preconstruction surveys to assess the diversity of other small mammals, reptiles and amphibians, with emphasis on threatened, rare, endemic or large concentrations of species. These will identify which species need to be translocated before construction, and address the following required modalities. <ul style="list-style-type: none"> A local ecologist team needs to conduct thorough checks for all forms of fauna prior to vegetation clearing within natural habitats. The objective of this set of activities is to adopt a proactive approach to prevent the loss of fauna without obstructing construction activities. The following procedures should be applied (but are not limited to there): Areas of natural vegetation designated to be cleared will be checked by a competent faunal ecologist prior to clearing, and all fauna would need be noted. Emphasis will be placed on breeding sites such as underground burrows and nests in trees (nests in branches and woodpecker-type holes in trees) and micro-habitats such as beneath rocks, fallen logs and loose bark. Any evidence of active breeding or residence in burrows will be highlighted and competent veterinary advice obtained on measures to safely translocate the species at risk to nearby appropriate and safe locations. Burrows may appear unused, but could be in use by smaller species such as bats, birds or reptiles 	Specialist report	Developer/Biodiversity Specialists	Prior to construction and site establishment	Pre-Construction compliance report

Aspect	Activity	No.	Mitigation/Management Action	Measure of Effectiveness	Responsibility	Frequency	Reporting Requirements
			<p>and would need to still be thoroughly investigated.</p> <ul style="list-style-type: none"> • Appropriate veterinary services would need to be involved in the translocation or forced movement of any medium-sized or large mammals, examples being animals having fallen into holes, become trapped or entangled by fences, crept inside vehicles or trapped within Staff Townships. • Competent ecologists and representatives of the relevant wildlife authority will be on site the day prior to vegetation clearing within natural habitats, and during clearing operations to safely translocate any animals encountered that are not able to evacuate the site on their own accord. Examples of animals that may require assistance includes young birds in nests, tortoises, chameleons, frogs, some snakes, invertebrates, fossorial species and any injured animals. 				
		10.	ZRA will develop an animal rescue procedure and implement this for dealing with faunal species found to be at risk from or posing a threat to Project operations. Such animals will be safely translocated to safe areas of similar habitat type where the animals can be released without harm to Project operations, surrounding communities or harm to that animal.	Animal rescue procedure	Developer/Contractor/Biodiversity Specialist	Prior to construction and site establishment	Pre-Construction compliance report
		11.	<p>A proactive approach towards wildlife management will be implemented to minimise the risks of wildlife incidents and conflict with humans associated with the Project. The following measures are expected to be required (but is not a comprehensive list):</p> <ul style="list-style-type: none"> • Onsite training will be provided for the identification and safe capture of African venomous snakes, with particular emphasis on species likely to be encountered in and around the Project area. • The Victoria Falls Wildlife Trust currently provide such services but cannot always be readily available in remote construction areas. Appropriate, collaboration agreements for a similar service will be required on the Zambian side. • Selected staff will be provided with training in the safe handling of venomous snakes on site. • Veterinary support will be available on call with contact numbers appropriately advertised and communicated. • Procedures in the event of encountering dangerous fauna will be developed and appropriately disseminated. • Competent veterinary capacity will be contactable to safely address any incidents involving any wildlife, such as animals caught within excavated pits, trapped within construction sites, injured through construction activities or similar events. 	Trained personnel Records and evidence of addressing dangerous wildlife (such as photos, species identified)	Developer/Contractor	Prior to construction and site establishment	Pre-Construction compliance report

Aspect	Activity	No.	Mitigation/Management Action	Measure of Effectiveness	Responsibility	Frequency	Reporting Requirements
			<p>All wildlife found to be injured, regardless of type, will be taken to appropriate facilities.</p> <ul style="list-style-type: none"> Faunal protection policies will be developed and enforced that prohibit illegal hunting, killing of animals, purchase of bush meat and keeping of pets. Induction programmes need to be developed for staff and contractors to raise the awareness of the diversity of animals present, risks associated with large wildlife and how to react when confronted by different species of large wildlife, and requirements to actively prevent the loss of any animals including snakes and species commonly considered to be vermin. 				
		12.	<p>Campaigns will be developed to raise public awareness of wildlife that suit the local conditions, and include (but not limited to):</p> <ul style="list-style-type: none"> Road signs to inform road users of the presence of wildlife, and identify wildlife road kill hot spots. Media campaigns (newspapers, radio, television and social media) at regular intervals with proactive messages on what can be done to reduce these risks. Data on the wildlife-traffic incidents that do occur could (at the discretion of ZRA) be made available to the general public, and specifically to stakeholders identified by the BGHES. 	Reduction in wildlife fatalities.	ZRA and Contractor	Prior to and throughout Construction	Detailed project planning designs; Evidence of campaigns launched
		13.	A detailed preconstruction baseline assessment of Taita Falcon nesting activity and possible nesting locations will be conducted for the entire length of the Batoka Gorge from Victoria Falls to 10 km downstream of the Dam Wall site.	Preconstruction baseline	<ul style="list-style-type: none"> Department of National Parks and Wildlife -Zambia Zimbabwe Parks and Wildlife Management Authority 	Prior to construction and site establishment	Pre-Construction compliance report
		14.	<p>The rim, cliffs and scree slopes of the Batoka Gorge will be declared No Go areas and measures must be taken to protect these areas through development of a conservation plan and restrictions on development to retain the wilderness character of the area, before the demand for tourism or residential developments rises as a result of the BGHES development.</p> <p>Establishment of additional Lodges producing noise and potential waste are likely to render Taita falcon nests unsuitable, similarly for other sensitive raptors. Locations of Taita Falcon nests must be kept confidential, as there is an illegal demand for Taita Falcon eggs and chicks. Ornithological organisations must however be involved in the design of fair control measures and restrictions for future developments along the rim of the Batoka Gorge and acceptable use of the reservoir.</p>	Conservation Plan developed for the Batoka Gorge and its rim.	<ul style="list-style-type: none"> Developer Zambia and Zimbabwe Conservation Authorities Ornithological Organisations 	During initial planning	Pre-Construction compliance Report
	Changes to project footprint	15.	Should there be any deviation of the current engineering plans; the new footprint areas must be investigated by heritage and biodiversity specialists.	Heritage and biodiversity studies	Developer/Specialist	Prior to construction and site establishment	Pre-Construction compliance report and notification to authorities

Aspect	Activity	No.	Mitigation/Management Action	Measure of Effectiveness	Responsibility	Frequency	Reporting Requirements
	Barriers to Wildlife Dispersal	16.	Barriers to wildlife dispersal will be addressed as effectively as possible, including security of crossings and other bottlenecks to allow animals to move safely, and adequate and appropriate access to water.	Detailed project planning designs	Designer and Contractor	Prior to and throughout construction	Detailed project planning designs
	Human Wildlife Conflict and Management of Staff Townships	17.	<ul style="list-style-type: none"> Staff Townships require an emergency response protocol in the event an animal gains access into the Staff Townships area which poses a risk to human safety, including a unique alarm signal and lock-down procedure. Staff Townships managers should run regular emergency drills to familiarise staff with this process. Comprehensive induction programmes will be developed for all staff and contractors that are accommodated in Staff Townships, that explain procedures regarding waste, how to respond to different animal encounters, how to handle wildlife incidents, etc. Informed specifications should be considered for wildlife fencing around Staff Townships. 	Reduction in human wildlife conflicts experienced in and around Staff Townships.	Contractor	Applicable throughout Construction	Operational Reports will be compiled and submitted
	General wildlife safety provisions for Staff Townships	18.	<ul style="list-style-type: none"> For general safety, Staff Townships will provision for the following: <ul style="list-style-type: none"> Wildlife guards who patrol for wildlife risk within the Staff Townships or construction sites, and are able to pro-actively deter animals before they become habituated or problematic. The protocol for managing snakes will be developed and implemented. Have contact details available (based on prior arrangement) for specialist advise to qualified doctors in the event of a venomous snake bite incident. In areas (both at Staff Townships and any site locations with food or waste) where baboons and Vervet monkeys are present an agreed protocol will be established to coax primates out of areas and away from people. 	Reduction in human wildlife conflicts experienced in and around Staff Townships s.	Contractor	Applicable throughout Construction	Operational Reports will be compiled and submitted
	Facilities provided to avoid biological-related incidents	19.	<ul style="list-style-type: none"> Windows will be fitted with mosquito screens, and secure primate-proof mechanisms to lock closed from the inside. Waste management measures and facilities (such as baboon-proof dustbins) that avoid creating opportunities for food scavengers. Walkways within Staff Townships will be provided with adequate lighting at night. Lights with a strong ultraviolet spectrum will be avoided. Yellow lights attract a lot less insects than lights with ultraviolet spectra. Security lighting will be inward and downward facing to avoid attracting insects and light pollution in remote areas, and to minimize the disturbance to nocturnal wildlife, birds and invertebrates 	Reduction in human wildlife conflicts experienced in and around Staff Townships.	Contractor	Applicable throughout Construction	Operational Reports will be compiled and submitted
Cultural Heritage	Dam, quarries and staff townships design	20.	Additional Pre-Construction surveys will be undertaken once all Project infrastructure footprints have been finalized. Surveys will be systematic and	Cultural heritage studies	Developer/Engineer/Heritage Specialist	Prior to construction and	Pre-Construction compliance report and notification to authorities

Aspect	Activity	No.	Mitigation/Management Action	Measure of Effectiveness	Responsibility	Frequency	Reporting Requirements
			<p>intensive, with the objective of identifying all sites that will be affected. Written Schemes of Investigation for this work will be agreed in advance with relevant regulatory organisations (the NMMZ in Zimbabwe and Livingstone Museum/the NHCC in Zambia).</p> <p>Should sites of medium or high archaeological sensitivity be identified by these pre-construction surveys, time and resources should be provided to permit more detailed recording/investigation ahead of the commencement of the construction process. This could involve any of the following methods of investigation:</p> <ul style="list-style-type: none"> • Trial trenching (using mechanical excavators to save time if necessary/appropriate) • Sample Excavation • Geomorphological investigation techniques such as coring • Archaeological monitoring/ watching briefs. 			site establishment	
		21.	<p>There are 13 sites of moderate and major significance on the Zimbabwean side that require further investigation. This work must first be approved in writing by NMMZ and the relevant permits issued. It can be conducted either by an independent but NMMZ-approved heritage specialist, or by NMMZ employees appointed directly by the Executive Director, NMMZ.</p> <p>Mitigation procedures include:</p> <ul style="list-style-type: none"> • Initial mapping to record what artefacts are present, their distribution, their context and to identifying any topographical associations. Sometimes this may involve controlled surface collection. <p>Based on these maps the heritage specialist will select representative places to excavate, recovering the artefacts under scientific procedures. Careful field notes must be taken and the artefacts, notes and all photographs must be lodged with NMMZ following analysis.</p> <ul style="list-style-type: none"> • NMMZ will assess all finalised excavation and analysis reports and may require additional work. This will be specified in writing. 	Survey reports and Written Schemes of Investigation	Developer/Heritage Specialist	Prior to construction and site establishment	Pre-Construction compliance report
		22.	<p>Where possible, Project infrastructure will be located in a way that avoids grave sites. Where this cannot be avoided, affected traditional authorities and families will be consulted with to understand their preference in terms of treatment of graves. Grave relocation will be in accordance with legislative requirements.</p>	Memoranda of understanding with the traditional authorities and affected families	Developer/Heritage Specialist	Prior to construction and site establishment	Pre-Construction compliance report
		23.	<p>Where impacts on sites of intangible value cannot be avoided, memoranda of understanding will be agreed with affected local communities setting out procedures for the relocation of graves and, where</p>	Memoranda of understanding with the traditional authorities and affected families	Developer/Heritage Specialist	Prior to construction and site establishment	Pre-Construction compliance report

Aspect	Activity	No.	Mitigation/Management Action	Measure of Effectiveness	Responsibility	Frequency	Reporting Requirements
			appropriate, compensation for the loss of sites on intangible/ritual significance.				
	Chance finds	24.	<p>A Chance Finds Procedure will be developed which will include the following procedures:</p> <ul style="list-style-type: none"> • Unexpected discoveries made during construction to be reported • Clear definition of roles and responsibilities and communication channels to report the finds to the authorities • Allowance for the temporary suspension of construction work in the vicinity of the chance finds until they could be assessed by a specialist should discoveries require further investigation; and • Agreed repositories for finds in Zambia and Zimbabwe <p>All procedures to be agreed in advance with NMMZ/NHCC.</p>	Chance Finds Procedure	Developer/Heritage Specialist	Prior to construction and site establishment	Pre-Construction compliance report
	Further cultural heritage work	25.	<p>A further outstanding cultural heritage investigation is required for the following:</p> <ul style="list-style-type: none"> • A water- reconnaissance of the entire length of the actual Batoka Gorge from the head of the intended BGHES dam (taking at the highest point according to the various alternative engineering designs) to the point of exit of water from the power plants. This work must consider all caves on the sides of the Gorge and any waterfall, rapid or pool. Chimamba Rapids and the Moemba Falls are places of particular importance. • The major tributary gorges where these will be flooded, even only in part, must be investigated to identify caves and potentially fossiliferous travertine deposits. 	Cultural heritage report	Developer	Prior to construction and site establishment	Pre-Construction compliance report
		26.	<p>A cultural heritage management method statement will be compiled in consultation with the regulatory authorities for the management of Chemapato Hill. The key objectives of this plan will be, in keeping with its traditions and significance to the local population, i) to document the site's current condition; ii) to document its historic significance and use; iii) to protect the site from future looting and disturbance.</p>	Cultural Heritage Management Method Statement approved by the regulatory authorities	Developer/Heritage specialist	Prior to construction and site establishment	Pre-Construction compliance report
	Changes to project footprint	27.	<p>If there any changes to the Project footprint, then heritage surveys will be conducted at an appropriate time (July to October) when there is no vegetation cover in the area.</p>	Heritage and biodiversity studies	Developer/Specialist	Prior to construction and site establishment	Pre-Construction compliance report and notification to the relevant authorities
Public Health and Safety	Recruitment	28.	<p>The ZRA will develop a recruitment strategy for employment of medical staff to avoid taking resources from the local area and prevent a negative impact on local health care.</p>	Recruitment strategy	Developer	Prior to construction and site establishment	Pre-Construction compliance report

Aspect	Activity	No.	Mitigation/Management Action	Measure of Effectiveness	Responsibility	Frequency	Reporting Requirements
	Spread of disease and demand on health services	29.	The ZRA will commit community investment funds to public health initiatives being implemented by regional/local Government and /or relevant NGOs. Such initiatives may include upgrading existing facilities, education and awareness campaigns, vaccination campaigns etc.	Community development programme	Developer	Prior to construction and site establishment	Pre-Construction compliance report
		30.	ZRA and its Contractor will develop a policy and management method statement to reduce the transmission of STIs, including HIV/ AIDS.	HIV/Aids Policy and Management Method Statement	Developer/Contractor	Prior to construction and site establishment	Pre-Construction compliance report
		31.	A baseline for workers and residents of the affected communities will be prepared in line with the requirements of the International Council of Mining and Metals (ICMM)'s Good Practise Guideline on HIV/Aids, Tuberculosis and Malaria. This will include the collection of data, where required to supplement previous data collection, relating to: <ul style="list-style-type: none"> • Demographics, such as population size, gender distribution and age distribution of the workforce and host community • Burden of disease (the level of morbidity and mortality caused by a disease, within a given area or target population) and epidemiology of HIV in the community and workforce • General standard of living within the study area, with the identification of vulnerable groups • Existing health services in terms of type, mix, quality, location, access and equity • Socio-economic status (variably defined as a mix of income, material, assets, status indicators, education, occupation) • Workforce housing, accommodation type and location • Ethnicity, if it influences health • Access to clean water and sanitation • Gender equality and female literacy rates • Food consumption and nutrition • Policy environment and political factors, such as levels of support for social services and health care services in the area • Government capacity to provide services • Details on existing workforce and/or community programmes targeting HIV/ Aids 	Baseline report	Developer/Health Specialist	Prior to construction and site establishment	Pre-Construction compliance report
		32.	ZRA will support local school education initiatives by government and NGOs regarding sexual education.	HIV/Aids policy and management method statement	Developer	Prior to construction and site establishment	Pre-Construction compliance report
		33.	ZRA will develop and implement an Integrated Malaria Control, Prevention and Treatment Programme.	Integrated malaria control, prevention and treatment programme	Developer/Contractor	Prior to construction and site establishment	Pre-Construction compliance report
		Social	Physical and economic displacement	34.	ZRA and its Engineers will position quarries, staff township areas and any dam infrastructure to avoid and/or minimise resettlement and economic displacement as far as practicable, taking into account	Documentation demonstrating that displacement impacts have been minimised	Developer/Engineer

Aspect	Activity	No.	Mitigation/Management Action	Measure of Effectiveness	Responsibility	Frequency	Reporting Requirements
			feasibility of the location, as well as safety and legislative restrictions.	through siting alternatives considered			
		35.	<p>Where physical and economic displacement is unavoidable, the ZRA will prepare a Resettlement Action Plan (RAP) and provide the required and agreed entitlement for loss of assets, revenue, and income resulting from both temporary and permanent economic and/or physical displacement prior to construction. Legislative requirements and international standards must be met.</p> <p>The Resettlement Action Plan will set out guidelines on how to deal with displacement including the following:</p> <ul style="list-style-type: none"> • Set out procedures to follow in order to address compensation issues • Identify affected households and host communities and provide a consultation record for the engagement with these parties • Identify vulnerable groups and how to minimise the impact on them • Identify and record assets held by each affected household that will be displaced • Detail how households will be compensated for loss of assets and disruption to livelihood activities • Present livelihood restoration measures • Present a resettlement monitoring and implementation plan • Present anticipated costs of resettlement. 	Approved Resettlement Action Plan (RAP) and Signed compensation and entitlement agreements by affected people/households	Developer/Resettlement Specialist	Prior to construction and site establishment	RAP Report
		36.	<p>As outlined in the Resettlement Policy Frameworks (RPFs), a proactive Stakeholder Engagement Programme will be undertaken for the resettlement process that builds on the ESIA stakeholder engagement programme and aligns with the overall Project Stakeholder Engagement Plan.</p> <p>ZRA will regularly communicate information and updates to communities about the Project, including the resettlement process and management of Project impacts. All communication will be undertaken in local languages and in a manner that seeks to manage potential expectations and involve affected people in the management of impacts. This activity should be continued for the life of the project.</p>	Detailed Stakeholder Engagement Plan for RAP	Developer/Resettlement Specialist	Prior to construction and site establishment	RAP Report
		37.	The ZRA will implement a grievance redress mechanism for the management of public grievances. The ZRA will implement and disseminate information regarding the grievance redress mechanism that has been developed for the Project. Stakeholders will be made aware of the key guiding principles of the mechanism, as well as how and where they can submit any grievances.	Grievance redress mechanism and effective reporting on the use thereof	Developer	Prior to construction and site establishment	Pre-Construction compliance report

Aspect	Activity	No.	Mitigation/Management Action	Measure of Effectiveness	Responsibility	Frequency	Reporting Requirements
		38.	As part of preparing the RAP, the ZRA will develop a livelihood diversification and improvement programme. The programme will focus on enterprise and livelihood development and a commitment to improving income levels in the Project area. This will involve the development of existing livelihoods as well as diversifying livelihoods.	Detailed livelihood restoration and improvement program	Developer/Livelihood Specialist	Prior to construction and site establishment	RAP Report
	Employment of local labour	39.	<p>A Local Employment Method Statement for the BGHES will be developed which will include the following aspects:</p> <ul style="list-style-type: none"> • Skills audits, including local people, young people and women. • A program of up-skilling, training and development to increase local availability of those trades with a local shortage. This will be undertaken in partnership with training and educational authorities and international organisations. • Job readiness training program. • Women's training and employment program. • Participation in events where potential employees can meet Project staff, learn about the Project, and register their interest for training and employment. • Recruitment and retention programs and strategies to attract skilled trades and supervision personnel from the local area. <p>This plan will be established at the outset of construction, and will support the employment approach for each of the Project components (i.e. dam, staff townships, quarries, and transmission lines)</p>	Local Employment Method Statement	Developer/Labour Specialist	Prior to construction and site establishment	Pre-Construction compliance report
		40.	Project specific Recruitment Policies will be developed by the ZRA as well as the Contractor and form part of the Conditions of Contract.	Contractor's contract	Developer/Contractor	Prior to construction and site establishment	Pre-Construction compliance report
		41.	Targets will be set to maximise the number of Zambian and Zimbabwean nationals, local, female, disabled, unskilled, skilled and highly skilled employees from the Project area. The ZRA will provide all its Contractors with the requirements related to hiring for inclusion in tendering documents related to human resources database, aspirational hiring targets, auditing arrangements, and (where relevant) training requirements.	Contractor's contract	Developer/Contractor	Prior to construction and site establishment	Pre-Construction compliance report
		42.	Employment opportunities will be publically advertised in appropriate newspapers, public libraries, the District Offices and in all relevant languages. All employment requirements will be advertised in a timely manner.	Contractor's contract	Developer/Contractor	Prior to construction and site establishment	Pre-Construction compliance report
		43.	There will be no requirement for applicants to make payments for applying for, or securing, employment on the proposed Project.	Advertisements to stipulate this	Developer/Contractor	Prior to construction and site establishment	Pre-Construction compliance report

Aspect	Activity	No.	Mitigation/Management Action	Measure of Effectiveness	Responsibility	Frequency	Reporting Requirements	
Local procurement		44.	The ZRA and its Contractor will develop and implement a procurement policy and method statement which will guide construction of all Project components. The main objective of the method statement will be to maximise local purchasing where possible in line with national legislation and tendering requirements, by directly working with local enterprises and by incentivising the Project's contractors to contract locally. This programme will be communicated effectively to local and regional stakeholders as early as possible.	Local content method statement (including policy for procurement of goods and services)	Developer/Contractor	Prior to construction and site establishment	Pre-Construction compliance report	
		45.	The ZRA and its Contractor will develop and maintain a database of all relevant local businesses that could be used as potential suppliers.	Local business database	Developer/Contractor	Prior to construction and site establishment	Pre-Construction compliance report	
		46.	The ZRA will promote capacity building to support in-country businesses to assist them with responding to tender opportunities and meeting administrative requirements of written communication, invoicing and reporting. This will be undertaken as follows: <ul style="list-style-type: none"> Through a tendering process, recognised Zambian and Zimbabwean and international organisations, institutions or Non-governmental Organisations (NGOs) should be invited to prepare and implement a programme for training, promoting and supporting entrepreneurship and small business development. This should be developed during the pre-construction and construction phases In collaboration with the respective Ministry of Trade and other relevant organisations, the Project should promote training of local and regional suppliers to deliver goods and services. This should be developed during the pre-construction and construction phases. 	Local business database and training records	Developer/Contractor	Prior to construction and site establishment	Pre-Construction compliance report	
		47.	When advertising procurement opportunities, the requirements for goods or services and the quality standards that will be applied will be clearly defined.	Advertisements to include these details	Developer/Contractor	Prior to construction and site establishment	Pre-Construction compliance report	
		48.	Local procurement will be promoted through events such as local /regional / national supplier trade shows. A small medium enterprise (SME) electronic portal will be created to facilitate the communication of contract opportunities and management training materials to SMEs providing relevant services.	Record of trade shows, electronic portal	Developer/Contractor	Prior to construction and site establishment	Pre-Construction compliance report	
		49.	Procurement targets will be defined in consultation with potential suppliers and key authorities and included in Contractors' contracts. Where possible, targets will be set for local procurement.	Contractor's contract	Developer	Prior to construction and site establishment	Pre-Construction compliance report	
		50.	Development and implementation of a PIIM Management Method Statement. The method statement will cover the following key elements: <ul style="list-style-type: none"> Communication. Minimising potential for in-migration. 	Project induced in-Migration management method statement	Developer/Planning Specialist/Government Agencies/NGOs	Prior to construction and site establishment	Pre-Construction compliance report	
		Immigration						

Aspect	Activity	No.	Mitigation/Management Action	Measure of Effectiveness	Responsibility	Frequency	Reporting Requirements
			<ul style="list-style-type: none"> Managing and directing influx. Enhancing physical infrastructure. Building human capacity to manage influx. Monitoring and evaluation of in-migration. Consideration of Project closure. <p>ZRA will partner with the national, regional and local Government agencies to implement the method statement, as well as with various national and international NGOs. It will be developed during the pre-construction phase and implementation will be aligned with the construction schedule of all aspects of the Project.</p>				
		51.	<p>ZRA will undertake the following in order to communicate the PIIM:</p> <ul style="list-style-type: none"> Engagement with Government authorities on issues, risks, threats, and opportunities regarding in-migration. Engagement with local communities to understand their concerns, raise awareness of risks and opportunities, and identify solutions to issues relating to in-migration. Development and implementation of a targeted communications plan in areas known to be potential sources of in-migration and, using migrant networks, inform potential in-migrants of the scale and nature of opportunities, manage their expectations, and where appropriate discourage them from moving to the Project area. <p>Communication of the Project's policy of recruiting through Local Employment Offices and the locations of those offices through activities targeted at potential in-migrants.</p>	Records of engagement	Developer/Stakeholder Engagement Specialist	Prior to construction and site establishment	Pre-Construction compliance report
	Training	52.	<p>The ZRA will develop and implement a Training Policy and relevant programmes prior to the commencement of construction. The policy programmes will:</p> <ul style="list-style-type: none"> Undertake a comprehensive training needs assessment to understand skills levels in the local area. Identify the particular training needs of the youth and women. Identify the skills gap and initiate mechanisms to train local people to meet the company's needs. Provide on-the-job and formal training (in partnership with relevant organisations) to local and regional contractors for un-skilling to allow transition of staff into operational phases. 	Training policy	Developer/Vocational Training Specialist	Prior to construction and site establishment	Pre-Construction compliance report
	Ecosystem services and livelihoods	53.	<p>The ZRA will undertake further investigations to understand and monitor impacts of dam construction and future operation on rafting companies and the viability of their businesses if this is still possible.</p>	Minutes from discussions with river rafting companies	Developer	Prior to construction and site establishment	Pre-Construction compliance report

Aspect	Activity	No.	Mitigation/Management Action	Measure of Effectiveness	Responsibility	Frequency	Reporting Requirements
	Community development	54.	The ZRA will establish a community development programme. The Project will consult with affected communities and in partnership with them, identify community development initiatives, based on their development priorities.	Community development plan (CDP)	Developer/ Stakeholder Engagement Specialist	Prior to construction and site establishment	Pre-Construction compliance report
		55.	Options to link up to current initiatives of the Zambezi Valley Development Fund, which currently has projects underway in the areas impacted on by the Lake Kariba Project, will be explored.	Agreement with ZVDF	Developer	Prior to construction and site establishment	Pre-Construction compliance report
		56.	A further evaluation of the capacity of Government Department's to absorb these projects and ensure their sustainability will be required closer to the time of implementing these community development initiatives. Initial consideration will be given to this during the development of the programme.	Study into capacity of role players	Developer	Prior to construction and site establishment	Pre-Construction compliance report
Stakeholder Engagement	Unmet expectations	57.	Develop a Stakeholder Engagement Program specifically for this component of the Project, to address project expectations and concerns.	Stakeholder Engagement Programme	Developer	Prior to construction and site establishment	Pre-Construction compliance report and notification to authorities
Construction							
Air Quality	Grievances	58.	The Project will develop and implement a grievance redress mechanism in the event of any dust complaints being received. All potentially impacted receptors will be informed of the nature of works to be carried out, the duration, as well as contact details for a Project representative that be contacted in the event of a complaint. All complaints will be managed as part of the Project's external feedback and grievance redress mechanism (mentioned above). The Project will make efforts to prevent grievances by monitoring conditions and surroundings and taking action to prevent dust emissions off the project site.	No grievances received relating to air quality	Contractor	Throughout construction	Noted in audit reports when relevant
		59.	The Contractor shall take all reasonable measures to minimize the generation of dust as a result of construction activities to the satisfaction of the Engineer and SHEQ Manager. Where practical and feasible, surface binding agents will be used on exposed open earthworks	No complaints received regarding dust management	Contractor	Throughout construction	Noted in audit reports when relevant
		60.	During high wind conditions, the Contractor shall comply with the SHEQ Managers instructions regarding dust suppression measures. The SHEQ Manager may request the temporary cessation of all construction activities where wind speeds are unacceptably high, and until such time as wind speeds return to acceptable levels.	No complaints received regarding dust management	Contractor	Throughout construction	Noted in audit reports when relevant
		61.	Surface treatment of roads and active work sites will be considered before and after a sensitive receptor. Dust suppression techniques such as wet suppression or chemical suppression (environmentally friendly and non-polluting) will be used to reduce dust on roads that exhibit an increase in dust entrainment. Speed limits will be adhered to within the project area for both treated haul roads and unpaved roads.	No complaints received regarding dust management	Contractor/SHEQ Manager	Throughout construction	Noted in audit reports when relevant

Aspect	Activity	No.	Mitigation/Management Action	Measure of Effectiveness	Responsibility	Frequency	Reporting Requirements
			A routine emissions and ambient air quality-monitoring program will be developed and implemented to determine whether there are any significant increases in emissions and impacts at sensitive receptors.				
	Vehicle Management	62.	Work vehicles transporting friable materials will be kept adequately covered to prevent materials being spread around and off the site. Where feasible and reasonable, vehicles and machinery that are compliant with recent emission standards (for example, EURO Tier 3) will be used. These vehicles will be maintained in reasonable working order. When not in use, vehicles will be switched off, unless impractical for health and safety reasons (for example maintenance of air conditioning).	Visual observations and dust complaints Vehicle inventory	Contractor	Throughout construction	Noted in audit reports when relevant
	Fuel use: Day to day emissions	63.	ZRA will commit to using the lowest possible sulphur fuel available so as to minimise harmful emissions.	Fuel inventories	Contractor/Developer	Throughout construction	Noted in audit reports when relevant
		64.	Where possible, favour the use of raw materials that are easier to transport (lighter less volume) plus consideration for on-site assembly of parts. Where there are limited raw material options, focus should be on optimisation of transportation.				
		65.	The quantities of construction material transported will be reduced /optimised where opportunity allows.				
	Concrete and cement work: Bulk silos/loading/batching/disposal	66.	Suitable screening and containment will be in place to prevent windblown contamination associated with bulk cement silos, loading and batching. All excess concrete will be physically removed to an approved waste site on completion of the concrete pour section and disposed of.	Method Statement	Contractor	Throughout construction	Noted in audit reports when relevant
	General	67.	Drop heights of material will be minimised. Where feasible and necessary, windbreaks (perpendicular to the prevailing wind direction and at a height of approx. 0.5m) will be erected around the Project Site including stockpiles. A "no unauthorised burning" policy will be implemented.	Visual observations and dust complaints	Contractor	Throughout construction	Noted in audit reports when relevant
Noise and Vibration	Grievances	68.	The Project will develop and implement a grievance redress mechanism that will address any noise complaints being received. All potentially impacted receptors will be informed of the nature of works to be carried out, the expected noise levels and duration, as well as contact details for a Project representative that be contacted in the event of a complaint. All complaints will be managed as part of the Projects external feedback and grievance redress mechanism (mentioned above). The Project will make efforts to prevent grievances by monitoring conditions and surroundings and taking action to prevent excessive noise emissions off the	No complaints received regarding noise	Contractor	Throughout construction	Engagement records and grievance redress mechanism

Aspect	Activity	No.	Mitigation/Management Action	Measure of Effectiveness	Responsibility	Frequency	Reporting Requirements
			Project site. Noise monitoring will be undertaken and will include operator noise measurements at the closest and most affected receptors identified for each stage of construction.				
	Blasting activities for powerhouse/dam wall/inundation/permanent and staff township development	69.	The Contractor shall take necessary precautions to prevent damage to special features and the general environment, which includes the removal of fly rock. Environmental damage caused by blasting/drilling shall be repaired at the Contractors expense to the satisfaction of the Engineer. The Contractor shall ensure that adequate warning is provided immediately prior to all blasting. The Contractor shall use blast mats or cover material during blasting.	Blasting Management Method Statement	Contractor	Throughout construction	Noted in audit reports when relevant
		70.	Ammonium-nitrate based explosives will not be used due to the production of toxic by-products.	Blasting Management Method Statement	Contractor	Throughout construction	Noted in audit reports when relevant
		71.	The Contractor will engage with local communities regarding blasting. This will include educating communities about the levels of noise to be expected, as well as informing them of the blasting schedule ahead of time and the safety practices that will put in place.	Records of notification	Contractor	Throughout construction	Noted in audit reports when relevant
		72.	Buildings within the potential damaging zone of the blast shall be surveyed preferably with the owner present, and any cracks or latent defects pointed out and recorded either using photographs or video. Failing to do so shall render the Contractor fully liable for any claim of whatsoever nature, which may arise.	Records of notification and monitoring records	Contractor	Throughout construction	Noted in audit reports when relevant
	General	73.	The Contractor shall limit noise levels (e.g. install and maintain silencers on machinery). When working in built-up areas, or any areas within audible distance of residents whether in urban, peri-urban or rural areas, the Contractor shall provide and use suitable and effective silencing devices for pneumatic tools and other plant that would otherwise cause a noise level exceeding 85 dB(A) during excavations and other work. Appropriate directional and intensity settings are to be maintained on all hooters and sirens.	No complaints received regarding noise	Contractor	Throughout construction	Noted in audit reports when relevant
		74.	No amplified music shall be allowed on office site and working areas. The use of radios, tape recorders, compact disc players, television sets etc. shall not be permitted unless the volume is kept sufficiently low as to avoid any intrusion on members of the public within range. The Contractor shall not use sound amplification equipment on Site unless in emergency situations.	No complaints received regarding noise	Contractor	Throughout construction	Noted in audit reports when relevant
		75.	Working hours in terms of the planning approval shall be adhered to. If works are to take place outside of normal working hours, the SHEQ Manager and the Engineer are to be notified and disturbance to the surrounding residents or land users is to be prevented. The Engineer will, where required, in turn notify the relevant authority of work done outside of normal working hours.	Proof of notification	Contractor/Engineer/SHEQ Manager	Throughout construction	Noted in audit reports when relevant
		76.	Periods of respite will be provided in the case of unavoidable maximum noise level events. These	Periods of respite in place	Contractor	Throughout construction	Noted in audit reports when relevant

Aspect	Activity	No.	Mitigation/Management Action	Measure of Effectiveness	Responsibility	Frequency	Reporting Requirements
			respite periods will be negotiated with the relevant local stakeholders.				
		77.	A summary of applicable noise criteria that relate to relevant work practices and nearby receptors will be developed. This summary will be shared in the environmental awareness training and made available/accessible so that all site operators can quickly reference noise information.	Summary of applicable noise criteria communicated and made available	Contractor	Throughout construction	Noted in audit reports when relevant
		78.	<ul style="list-style-type: none"> Where feasible and reasonable, the dropping of materials from height will be avoided. Where feasible and reasonable, metal-to-metal contact on equipment will be avoided. Effective mufflers, enclosures and low-noise tool bits and blades will be selected, where necessary. The hours of operation for specific equipment or operations will consider community sensitivities (e.g. trucks or machines operating in or passing through community areas). 	Records / visual observations	Contractor	Throughout construction	Noted in audit reports when relevant
		79.	Where practical, the use of the natural topography will be used for noise shielding.	Effective use of natural topography for noise shielding	Contractor	Throughout construction	Noted in audit reports when relevant
		80.	As far as practical, the noise levels from longer-term construction activities will be aligned to receptors and time of work, or to other standards that have been agreed with the local authority.	Records associated with noise monitoring campaigns	Contractor	Throughout construction	Noted in audit reports when relevant
	Vehicle and Machinery Management	81.	<ul style="list-style-type: none"> Where feasible and reasonable, mobile plant parking near residences and other sensitive land uses will be prohibited. Exclusion zones where the offloading of Project equipment / materials from trucks is not permitted will be established. Machinery will be positioned as to minimise noise transmission towards noise sensitive receptors. 	Records / visual observations	Contractor	Throughout construction	Noted in audit reports when relevant
	Training	82.	In addition to the abovementioned management actions, training in noise control procedures and equipment operation will be provided to the relevant personnel.	Training records	Contractor	Throughout construction	Training records
Soils	Site clearance: Vegetation clearance/bulk earthworks/fencing	83.	The Contractor shall take all reasonable measures to limit erosion and sedimentation due to the construction activities. Where erosion and/or sedimentation, whether on or off the Site, occurs despite the Contractor complying with the foregoing, rectification shall be carried out in accordance with details specified by the SHEQ Manager. Where erosion and/or sedimentation occur due to the fault of the Contractor, rectification shall be carried out to the reasonable requirements of the SEQ Manager.	Rehabilitation of erosion areas	Contractor	Throughout construction	Noted in audit reports when relevant
		84.	Vegetation should be left <i>in-situ</i> wherever possible, and re-vegetation of bare soils before the next rainy season should occur as soon as possible.	Rehabilitation effectiveness	Contractor	Throughout construction	Noted in audit reports when relevant
		85.	Any runnels or erosion channels developed during the construction period shall be backfilled and compacted. Stabilisation of cleared areas to prevent and control erosion shall be actively managed.	Rehabilitation of erosion areas	Contractor	Throughout construction	Noted in audit reports when relevant

Aspect	Activity	No.	Mitigation/Management Action	Measure of Effectiveness	Responsibility	Frequency	Reporting Requirements
			Consideration and provision shall be made for various methods, namely, brush-cut packing, mulch or chip cover, straw stabilising (at a rate of one bale/square meter and rotorvated into the top 100 mm of the completed earthworks), watering, soil binders and anti-erosion compounds, mechanical cover or packing structures (e.g. Hessian cover).				
	Site establishment: Traffic	86.	Traffic and movement over stabilised areas shall be restricted and controlled, and damage to stabilized area shall be repaired and maintained to the satisfaction of the SHEQ Manager and Engineer.	Rehabilitation of erosion areas	Contractor	Throughout construction	Noted in audit reports when relevant
	Site establishment: Surface drainage	87.	Effective construction site drainage measures, utilising cut-off drains (to divert surface runoff from exposed soils or construction areas), oil interceptors and silt traps to manage and retain sediments on site.	Stormwater Management Method Statement	Contractor	Throughout construction	Noted in audit reports when relevant
		88.	All drainage channels, flow control structures and culverts should be designed to transmit an appropriate design flood event based upon international best practices.	Stormwater Management Method Statement	Contractor	Throughout construction	Noted in audit reports when relevant
		89.	The Contractor will periodically inspect construction site drainage systems, maintain these, clear them of debris and design flood calculations will be checked and re-assessed if visual evidence suggests that peak flows may have been underestimated.	Records / visual observations	Contractor	Throughout construction	Noted in audit reports when relevant
	Site clearance: Removal of topsoil	90.	If topsoil /top material is removed from areas cleared of vegetation, it will be retained for future landscaping use. Top material will exclude litter, building rubble, alien plant material or any other waste. All topsoil, and specifically any topsoil from areas which are likely to contain bulbs, must be stripped and stockpiled for re-use in landscaped areas. This will constitute at least a 300 mm layer.	Appropriately managed topsoil stockpiles	Contractor	Throughout construction	Noted in audit reports when relevant
	Site clearance: Topsoil stockpiling	91.	Topsoil will be stored in areas demarcated by the SHEQ Manager and Engineer and in piles not higher than 2 m, and may not be removed from the site, or used for any purpose other than in the final landscaping of the site. The stockpiles will not be compacted or disturbed, and will be domed at the top to promote runoff. The period between the stockpiling of topsoil and its utilization will be as short as possible, and ideally the topsoil should be transferred to its intended site of use immediately following site clearance and stockpiling. This would also avoid double handling.	Appropriately managed topsoil stockpiles	Contractor/SHEQ Manager/Engineer	Throughout construction	Noted in audit reports when relevant
		92.	Stockpiles that are to be stored for less than three months will be covered with shade-cloth or geotextile fabrics or similarly suitable material to prevent erosion, and kept moderately moist in order to maintain the vitality of the soil. If stockpiles are to be stored for more than three months a protective vegetation layer must be established to cover topsoil stockpiles in order to protect them against erosion and desiccation. The stockpile must be kept moist in order to maintain the vitality of the vegetation. Vegetation may not consist of invasive alien vegetation, but must comprise grass or ground covers.	Appropriately managed topsoil stockpiles	Contractor	Throughout construction	Noted in audit reports when relevant

Aspect	Activity	No.	Mitigation/Management Action	Measure of Effectiveness	Responsibility	Frequency	Reporting Requirements
	Workshops: On-site maintenance	93.	Where practical, all maintenance of plant on the site will be performed in the workshop. If it is necessary to do maintenance outside of the workshop area, the Contractor will obtain the approval of the Engineer prior to commencing activities.	Engineer approval	Contractor/Engineer	Throughout construction	Noted in audit reports when relevant
		94.	The Contractor will ensure that the workshop and other plant maintenance facilities, including those areas where, after obtaining the Engineer's approval, the Contractor carries out emergency plant maintenance, there is no contamination of the soil or vegetation. The workshop will have a smooth impermeable floor either constructed of concrete or thick plastic covered with sufficient sand to protect the plastic from damage. If constructed of concrete the floor will be bunded and sloped towards an oil trap or sump to contain any spillages of substances (e.g. oil). The workshop area should have a storm water drainage system linked to a three-phase oil separator A Method Statement detailing the design and construction of the workshop must be submitted to the Engineer for approval.	Site Establishment Method Statement	Contractor/Engineer/SHEQ Manager	Duration of construction phase. Method statement must be approved at start of contract.	Noted in audit reports when relevant
	Equipment : Servicing and repairs of equipment	95.	When servicing equipment, drip trays will be used to collect the waste oil and other lubricants. Drip trays will also be provided in active work areas for stationary plant (such as compressors) and for "parked" plant (such as scrapers, loaders, vehicles).	Use of drip trays	Contractor	Throughout construction	Noted in audit reports when relevant
		96.	All vehicles and equipment will be kept in good working order and serviced regularly. Leaking equipment will be repaired immediately or be removed from the site.	Vehicle maintenance records	Contractor	Throughout construction	Noted in audit reports when relevant
	Equipment: Washing of equipment	97.	The washing of equipment will be restricted to preventative maintenance requirements only. All washing will be undertaken in the workshop or maintenance areas, and these areas must be equipped with a suitable impermeable floor and sump/oil trap. The use of detergents for washing will be restricted to low phosphate and nitrate containing and low sudsing-type detergents.	Records / visual observations	Contractor	Throughout construction	Noted in audit reports when relevant
	Fuel storage, handling and transportation	98.	All fuel is to be stored within a demarcated area in the laydown area. No refuelling of vehicles or machinery is to take place outside of this demarcated area unless authorised by the SHEQ Manager. The SHEQ Manager will be advised of the area that the Contractor intends using for the storage of fuel.	SHEQ Manager approval	Contractor	Throughout construction	Noted in audit reports when relevant
		99.	The Contractor will ensure that all liquid fuels (petrol and diesel) are stored in tanks with lids, which are kept firmly shut. Only empty and externally clean tanks may be stored on the bare ground. All empty and externally dirty tanks will be sealed and stored in an area where the ground has been protected.	Records / visual observations	Contractor	Throughout construction	Noted in audit reports when relevant
		100.	Tanks containing fuels will be situated on a smooth impermeable surface (plastic or concrete) base with a bund (if plastic, it must have sand on top to prevent perishing) to contain any possible spills and prevent infiltration of fuel into the ground. The impermeable	Engineer approval	Contractor	Throughout construction	Noted in audit reports when relevant

Aspect	Activity	No.	Mitigation/Management Action	Measure of Effectiveness	Responsibility	Frequency	Reporting Requirements
			lining will extend to the crest of the bund and the volume inside the bund will make up 110 percent of the total capacity of all the storage tanks.				
		101.	The floor of the bund will be sloped towards an oil trap or sump to enable any spilled fuel to be removed. A spill kit for hydrocarbon absorption/remediation will be kept on site to reduce the risk of pollution. Bulk fuel storage (which is anticipated to include Above Ground Storage Tanks [ASTs] with a volume range of approximately 4.5 to 46 m ³) and bunded areas will have overhead cover to prevent rain from entering the bunded area. The Contractor will keep fuel under lock and key at all times.	Engineer Approval	Contractor	Throughout construction	Noted in audit reports when relevant
		102.	Fuel should not be stored or dispensed in drums. Small fuel tankers should be used for the re-fuelling of construction vehicles and the drum will not be tipped in order to dispense fuel. The dispensing mechanism used to dispense fuel from the drums will be stored in a waterproof container when not in use.	Records / visual observations	Contractor	Throughout construction	Noted in audit reports when relevant
		103.	Transportation of fuels should be undertaken by registered suppliers according to National provisions. During fuel tanker delivery, the tanker driver must be present at all times during offloading of product. An emergency cut-off switch must be installed to immediately stop fuel delivery should an accident occur. An anti-flash nozzle must be installed at the end of the vent pipe with a fuel dispenser equipped with an automatic cut-off switch to prevent fuel tank overfills.	Records / visual observations	Contractor	Throughout construction	Noted in audit reports when relevant
		104.	Where reasonably practical, vehicles and equipment will be refuelled at a designated re-fuelling area or at the workshop as applicable. If it is not reasonably practical, then the surface under the temporary refuelling area will be protected against pollution and drip trays used to the reasonable satisfaction of the Engineer prior to any refuelling activities. The Contractor will ensure that there is always a supply of appropriate material readily available to absorb/breakdown and where possible be designed to encapsulate minor hydrocarbon spillage. The quantity of such materials will be able to handle a minimum of 200 litres of hydrocarbon liquid spill. This material must be approved by the Engineer prior to any refuelling or maintenance activities.	Engineer Approval	Contractor	Throughout construction	Noted in audit reports when relevant
	Concrete and cement work: Batching area/storage and stockpiling	105.	The location of the batching areas (including the location of cement stores and sand and aggregate stockpiles) will be indicated on the site layout plan and approved by the SHEQ Manager and Engineer. A Method Statement indicating the layout and preparation of this facility is required in this regard. Cement is to be stored in a secure weatherproof location to avoid contamination of the environment.	Site Establishment Method Statement Concrete Mixing and Batching Method Statement	Contractor/Engineer/SHEQ Manager	Throughout construction Method statement must be approved at start of contract.	Noted in audit reports when relevant
	Concrete and cement work: Surface drainage of batching area	106.	All runoff from batching areas will be strictly controlled so that contaminated water does not enter storm water or run-off into the Zambezi River. This should be achieved by the installation of a stormwater	Records / visual observations	Contractor	Throughout construction	Noted in audit reports when relevant

Aspect	Activity	No.	Mitigation/Management Action	Measure of Effectiveness	Responsibility	Frequency	Reporting Requirements
			drainage system that transports polluted run-off to the settling ponds. Plastering boards and mixing trays will be used at all mixing and supply points. Cleaning of equipment and flushing of mixers will not result in pollution of the surrounding environment.				
	Concrete and cement work: Bulk silos/loading/batching/disposal	107.	Suitable screening and containment will be in place to prevent windblown contamination associated with bulk cement silos, loading and batching. All excess concrete will be physically removed to an approved waste site on completion of the concrete pour section and disposed of.	Records / visual observations	Contractor	Throughout construction	Noted in audit reports when relevant
	Laydown areas: Storage of materials	108.	The Contractor will supply and maintain adequate and suitable sheds for the storage of materials. Sheds for the storage of materials that may deteriorate or corrode if exposed to the weather will be weatherproof, adequately ventilated and provided with raised floors.	Site layout plan to be approved by the Engineer and SHEQ Manager	Contractor	Throughout construction	Noted in audit reports when relevant
		109.	The Contractor will ensure that any delivery drivers are informed of all procedures and restrictions (including "no go" areas) required to comply with the ESMP. The Contractor shall ensure that these delivery drivers are supervised during off loading, by someone with an adequate understanding of the requirements of the ESMP.	Proof of notification	Contractor	Throughout construction	Noted in audit reports when relevant
		110.	Storage of materials is to be as per standards and internal management procedures. All manufactured and/ or imported material will be stored within the staff townships camp and/or designated laydown areas and documented accordingly. All lay down areas outside of these designated areas will be subject to the Engineer's and SHEQs written approval.	Engineers and SHEQ Manager approvals	Contractor/SHEQ Manager/Engineer	Throughout construction	Noted in audit reports when relevant
	Washing and ablutions	111.	Washing, whether of the person or of personal effects, and acts of excretion and urination are strictly prohibited other than at the facilities provided. Latrine and ablution facilities and first-aid services will comply with the regulations of the Zimbabwe and Zambia and shall be maintained in a clean and sanitary condition to the satisfaction of the Engineer and SHEQ Manager.	No reported violations, Compliance with regulations, Approval from the Engineer and SHEQ Manager	Contractor	Throughout construction	Noted in audit reports when relevant
		112.	The Contractor will provide suitable sanitary arrangements at the staff townships and approved points around the designated work area to allow easy access for all employees on the site. Project staff are not permitted to commence with work on the site without suitable toilet facilities being available for them.	Compliance with regulations, Approval from the Engineer and SHEQ Manager	Contractor	Throughout construction	Noted in audit reports when relevant
		113.	Sanitary facilities will be located within 100 m from any point of work, but not closer than 50 m to any water body. One chemical toilet is to be provided on site for every 15 contract personnel at each working area. These toilets must have doors and locks and shall be secured to prevent them blowing over. Toilet paper will be provided.	Records / visual observations	Contractor	Throughout construction	Noted in audit reports when relevant

Aspect	Activity	No.	Mitigation/Management Action	Measure of Effectiveness	Responsibility	Frequency	Reporting Requirements	
		114.	Chemical (portable) toilets are to be periodically emptied on a weekly basis by an approved and reputable contractor. The contractor will ensure that no spillage occurs when the toilets are cleaned or emptied and that the contents are removed from the site. Discharge of waste from toilets into the environment and burial of waste is strictly prohibited.	Records / visual observations	Contractor	Throughout construction	Noted in audit reports when relevant	
Surface and groundwater	Grievances	115.	The Project will develop and implement a grievance redress mechanism in the event of any water complaints being received.	No complaints received regarding water impacts	Contractor	Start of construction	Engagement records and grievance redress mechanism	
	Site demarcation and establishment: Staff townships and construction sites	116.	The Contractor will not permit his employees to make use of the Zambezi River for the purposes of swimming, personal washing and the washing of machinery or clothes.	No reported incidents	Contractor	Throughout construction	Noted in audit reports when relevant	
	Material storage: Storage of building material/bunding	117.	Storage of materials is to be as per standards and internal management procedures. All building materials will be stored at least 50 m away from aquatic ecosystems and the areas banded appropriately such that there will be no runoff from these areas towards aquatic systems. All building materials will be removed after construction works.	Site plan	Contractor	Throughout construction	Noted in audit reports when relevant	
	Material storage: Stockpiling	118.	No stockpiling of waste or fill materials close to or within channels or community water supplies will be permitted.	Site plan	Contractor	Throughout construction	Noted in audit reports when relevant	
	Material handling: Transport	119.	Materials will be appropriately secured to ensure safe passage between destinations. Loads including, but not limited to, sand, stone chips, fine vegetation, refuse, paper and cement, will have appropriate cover to prevent them spilling from the vehicle during transit. The Contractor will be responsible for any clean-up resulting from the failure by his employees or suppliers to properly secure transported materials.	No spillage of materials	Contractor	Throughout construction	Noted in audit reports when relevant	
	Workshops: On-site maintenance	120.	<i>Refer to Mitigation/Management Action No. 87 to 88</i>					
	Equipment : Servicing and repairs of equipment	121.	<i>Refer to Mitigation/Management Action No. 89 to 90</i>					
	Equipment : Washing of equipment	122.	<i>Refer to Mitigation/Management Action No. 91</i>					
	Fuel storage, handling and transportation	123.	<i>Refer to Mitigation/Management Action No. 92 to 98</i>					
	Concrete and cement work: Batching area/storage and stockpiling	124.	<i>Refer to Mitigation/Management Action No. 99</i>					
	Concrete and cement work: Surface drainage of batching area	125.	<i>Refer to Mitigation/Management Action No. 100</i>					
	Concrete and Cement Work: Bulk silos/loading/batching/disposal	126.	<i>Refer to Mitigation/Management Action No. 101</i>					
	Laydown areas: Storage of materials	127.	<i>Refer to Mitigation/Management Action No. 102 to 104</i>					
Staff townships and construction sites: Washing and ablutions	128.	<i>Refer to Mitigation/Management Action No. 105 to 108</i>						
Visual	General	129.	All site establishment components (as well as equipment) will be positioned to limit visual intrusion and the size of the area disturbed. The type and colour of roofing and cladding materials comprising the Contractor's temporary structures will be selected to reduce reflection. The Contractor's site office and	No complaints received regarding visual impact	Contractor	Throughout construction	Noted in audit reports when relevant	

Aspect	Activity	No.	Mitigation/Management Action	Measure of Effectiveness	Responsibility	Frequency	Reporting Requirements
			working areas will be fenced, and where feasible will be screened via the attachment of shade cloth or equivalent to the fence surrounding the office and working areas.				
		130.	The Contractor shall ensure that any lighting installed on the site for his activities does not interfere with road traffic or cause a reasonably avoidable disturbance to the surrounding community or other users of the area.	No complaints received regarding visual (lighting) impact	Contractor	Throughout construction	Noted in audit reports when relevant
		131.	If any parts of site such as staff townships must be lit at night, this should be done with low-UV type lights (such as most LEDs), which do not attract insects and which should be directed downwards.	No complaints received regarding visual (lighting) impact	Contractor	Throughout construction	Noted in audit reports when relevant
	Laydown areas: storage of materials	132.	The Contractor will supply and maintain adequate and suitable sheds for the storage of materials.	Site layout plan to be approved by the Engineer	Contractor	Throughout construction	Noted in audit reports when relevant
Biodiversity	Site demarcation and establishment: Erection of fencing/definition of "no go zones"	133.	The Contractor shall erect and maintain permanent and/ or temporary fences on the Zimbabwean side to a specification that is adequate to prevent entry by wildlife (based on evaluation by the Zimbabwe Wildlife Authorities - Item 37) and in the locations directed by the Engineer. Such fences shall, if so specified, be erected before undertaking designated activities. This does not include the proposed two staff townships for labourers.	Fences for no-go areas, Exclusion of dangerous fauna	Contractor/Engineer	At start of any activity requiring fencing	Noted in audit reports when relevant
		134.	The Contractor will restrict all activities, materials, equipment and personnel to within the area specified, and shall restrict activities to only those areas that are necessary to undertake the works. The demarcated buffer areas around sensitive ecological areas are to be managed as "no go" areas. The Contractor will ensure that, insofar as he has the authority, no person, machinery, equipment or material enters the "no go" areas at any time.	Fences for no-go areas	Contractor/SHEQ Manager	Throughout construction	Noted in audit reports when relevant
		135.	The Contractor will not deface, paint, damage or mark any natural features (e.g. rock formations or large trees) situated in or around the site for survey or other purposes unless agreed beforehand with the Engineer and SHEQ Manager. Any features affected by the Contractor in contravention of this clause will be restored/ rehabilitated to the satisfaction of the Engineer and SHEQ Manager.	No damages to natural features	Contractor	Throughout construction	Noted in audit reports when relevant
	Site demarcation and establishment	136.	Except to the extent necessary for the carrying out of the Works, flora shall not be removed, damaged or disturbed nor shall any vegetation be planted.	No reported incidents	Contractor	Duration of the project.	Noted in audit reports when relevant.
		137.	Construction sites will be surveyed by a Biodiversity specialist shortly before the onset of construction activities to identify fauna present and determine which species can be flushed out, and which need to be translocated to safe locations. During construction, any fauna directly threatened by the construction activities will be removed to a safe location by a suitably qualified person.	Specialist report	Contractor/Developer/Biodiversity Specialist	Throughout construction	Noted in audit reports when relevant
		138.	A Biodiversity Protection Statement is required to guide the conservation of plants and animals during	Awareness training, Biodiversity Protection Statement	Developer/Contractor/Biodiversity Specialist	Throughout construction	Noted in audit reports when relevant

Aspect	Activity	No.	Mitigation/Management Action	Measure of Effectiveness	Responsibility	Frequency	Reporting Requirements
			<p>construction, and is to be applicable for all staff and contractors involved in the project.</p> <p>The following activities will be prohibited for ZRA personnel, dam operational staff and contractors within and surrounding the Project Area, both during and outside work hours:</p> <ul style="list-style-type: none"> • Any forms of hunting of wildlife by staff and contractors. • Purchase, sale or transport of any bush meat products or parts of animals (horns, shells, etc.) from local communities or passing traders. • Collection of any animals or animal products for consumption, medicinal or other use. • Camp residents keeping pets, either introduced species such as cats or dogs, or native wildlife • The intentional killing of any animals including snakes, lizards, birds or other animals. Awareness of the Animal Rescue method statement will be promoted as a means of addressing the presence of animals at risk or presenting a risk to the implementation of activities (refer to item 40). • Camp residents purchasing local wildlife or wildlife products for any reason. • Sellers of wildlife must not to be allowed on any of the project sites. Such people should be reported to local authorities or wildlife agencies as appropriate. • Contamination or disposal of waste in the aquatic environments. <p>ZRA must include such information as part of the site induction process so that all workers are aware of these prohibitions, as well as including it in environmentally related information campaigns such as a quarterly newsletter.</p>				
		139.	Where the use of herbicides, pesticides and other poisonous substances has been specified, the Contractor shall submit a Method Statement that complies with the product manufacturer's MSDS. Only products authorized for use in Zambia or Zimbabwe will be used, and in accordance with accepted means of application.	Hazardous Substances Method Statement	Contractor	Throughout construction	Noted in audit reports when relevant
	Laydown areas: Storage of materials	140.	<i>Refer to Mitigation/Management Action No. 97 to 99</i>				
	Workshops: On-site maintenance	141.	<i>Refer to Mitigation/Management Action No. 82 to 83</i>				
	Inundation/construction of the dam wall	142.	Specialist ornithologists will be involved in experimental creation of artificial nesting facilities for Taita Falcons on the dam wall and in the cliffs in areas that are suitable but do not jeopardise natural nesting habitat	Report from ornithologists	Developer/Contractor/Specialist Ornithologists	At start of construction phase	Noted in audit reports when relevant
	Inundation	143.	Threatened and endemic plant species that are at risk of being inundated or lost due to construction activities will, where feasible and practical, be	Records of discussion. Records of relocation	Developer/Contractor/Specialist Botanist	Prior to inundation	Noted in audit reports when relevant

Aspect	Activity	No.	Mitigation/Management Action	Measure of Effectiveness	Responsibility	Frequency	Reporting Requirements
			<p>relocated to safe areas of similar habitat. Implementation of this measure will require active liaison and engagement between government and private stakeholders.</p> <p>Botanists will survey habitats to be inundated at least a year ahead of expected inundation to determine the following:</p> <ul style="list-style-type: none"> Identify plants for translocation, Determine appropriate translocation procedures, equipment, labour requirements and timing; Identify suitable areas of similar habitat where plants can be safely translocated to. Develop a monitoring programme to measure the success of the programme. 				
	Dam wall development including water outlet works and spillway	144.	ZRA and its Contractor will implement the recommended environmental flows to ensure sufficient water is released during construction to maintain downstream fish populations and restrict impacts to associated habitats and other fauna.	Downstream monitoring results	Developer/Contractor/Engineer	Throughout construction	Noted in audit reports when relevant
	Inundation/dam wall construction	145.	<p>A erosion and sediment management method statement will be developed which will consist of:</p> <ul style="list-style-type: none"> Monitoring sediment in the reservoir, including quantitative and qualitative analysis of sediment to verify properties and pollution levels. Minimising sediment deposition in reservoirs where possible by sluicing or density current venting. Removing accumulated deposits where possible by drawdown flushing (drawing the water level down during high-flow seasons), and excavation of sediments. Catchment management programmes to reduce sediment inflow to the reservoir where possible as part of a basin-wide plan. 	Erosion and Sediment Method Statement	Developer/Contractor/Specialist	Throughout construction	Noted in audit reports when relevant
	Inundation	146.	<p>Capacity will be established in Zambia and Zimbabwe for scientific development and management of the fisheries resource in the BGHES Reservoir.</p> <p>In order to optimise economic benefit of the reservoir as well as maintain ecological balance, the following will be undertaken:</p> <ul style="list-style-type: none"> Kapenta will be introduced to utilise the pelagic habitat that will be created and replace the diversity of riverine fish species unable to adapt to the changing conditions. Tiger fish fingerlings will be introduced as insufficient breeding habitat will be available to maintain a stable fish predator-prey relationship. Young eels will be introduced to complement the fish diversity. 	Establishment of fisheries management capacity within the appropriate Zambian and Zimbabwean authorities	Developer / Appropriate Zambian and Zimbabwean Authorities	Needs to be established prior to operation of the BGHES	Noted in audit reports when relevant

Aspect	Activity	No.	Mitigation/Management Action	Measure of Effectiveness	Responsibility	Frequency	Reporting Requirements
			Fisheries management will be adapted from the lessons learnt on Kariba and applied to the BGHES to maximise the productivity of the resource.				
	Coffer dams	147.	Water collected within the cofferdam should not be released directly into the watercourse. This water needs to be isolated and suspended material allowed to settle out before release.	Water Resources Method Statement	Contractor/Engineer	Throughout construction	Noted in audit reports when relevant
	Blasting activities for powerhouse/dam wall/inundation/permanent and construction camp development	148.	The SHEQ Manager will be informed of large fish mortality events resulting from blasting activities.	Records of fish mortalities associated with blasting	Contractor	Throughout construction	Noted in audit reports when relevant
	Alien flora/fauna species management	149.	Decomposition of vegetation will cause eutrophication of the water during initial filling of the reservoir. Considerable flushing of water will be required during the initial stages to prevent an accumulation of nutrients and severely eutrophied water body that will give rise to severe blooms of floating invasive water weeds.	Water quality measurements Occurrence of floating weeds	Developer/Contractor/Specialist	During reservoir filling	Noted in audit reports when relevant
		150.	Effective biological control of the floating aquatic weeds will be required if an outbreak occurs, but will need to be implemented in close collaboration with the Zambezi Watercourse Commission (ZAMCOM) on Biological Control.	Occurrence of floating weeds	Developer/Contractor/Specialist	During reservoir filling	Noted in audit reports when relevant
	Final rehabilitation of quarries	151.	Reshaping of quarries as part of the rehabilitation programme will consider the surrounding landscape and avoid the development of new landscape features. Future reshaping will be considered prior to excavation /establishment of quarries to minimise costs at a later stage. The following should be considered for establishment of quarry areas and final rehabilitation: <ul style="list-style-type: none"> The Batoka Gorge includes many cliff faces along the edges with scree slopes below. Cliff faces with a scree slope at a similar angle would therefore be appropriate for some sides of the quarry pits. Cliff faces provide nesting habitat for various raptor species and storks. Suitable ledges for nesting located in inaccessible places could potentially provide ecological benefits. Soils need to be separated when excavated and stockpiled appropriately, so that these can be returned for future revegetation of rehabilitated quarries. Quarry areas should be free draining. 	Detailed project planning designs	Developer/Contractor/Specialist	At the end of construction and site rehabilitation	Noted in audit reports when relevant
	Final rehabilitation of disposal areas	152.	Where possible the visual impact of disposal areas should also be considered. At closure, not all waste rock will be used as backfill for the quarries. As such, the disposal area will require final rehabilitation. The final slopes of disposal areas should be irregular and mimic the surrounding landscapes. The potential for erosion of the rehabilitated disposal area will be monitored and repaired when it occurs.	Detailed project planning designs	Developer/Contractor/Specialist	At the end of construction and site rehabilitation	Noted in audit reports when relevant

Aspect	Activity	No.	Mitigation/Management Action	Measure of Effectiveness	Responsibility	Frequency	Reporting Requirements
Cultural Heritage	Chance finds	153.	During the construction phase, a chance-finds procedure will be applied should substantial fossil remains such as vertebrate bones, teeth or trackways, plant-rich fossil lenses or dense fossil burrow assemblages be exposed by excavation or discovered within the development footprint. The responsible SHEQ Manager will safeguard the fossils, preferably <i>in situ</i> , and alert the responsible heritage management authority so that appropriate action can be taken by a professional palaeontologist, at the developer's expense.	Specialist report	Contractor/Developer/SHEQ Manager/Heritage Specialist	Throughout construction	Noted in audit reports when relevant
		154.	Should a specialist confirm a genuine artefact and recommend further study of the area, work in the area is to cease until further notice and the relevant heritage author agency is to be informed forthwith by the archaeologist. A maximum of 30 days will be set aside in the construction program for the recovery of archaeological material where/if discovered.	Specialist report	Contractor/Developer/SHEQ Manager/Heritage Specialist	Throughout construction	Noted in audit reports when relevant
Public Health and Safety	Permanent staff townships	155.	ZRA and its Contractor will allow the wider public to access health centres located within the permanent staff townships.	Recorded public access	Developer/Contractor	Throughout construction	Noted in audit reports when relevant
	Protection of public health	156.	ZRA and its Contractor will develop and implement an Integrated Malaria Control, Prevention and Treatment Programme. The programme should include the following key aspects and commitments: Vector Management: <ul style="list-style-type: none"> Avoid the creation of mosquito breeding conditions through creation of proactive surface water management during construction activities e.g., excavation for road building, leaking water pipes and engineering works that interfere with the natural lines of water drainage Reduce or elimination of mosquito breeding habitats e.g., level ground, appropriate drainage, and vegetation clearance Reduce the presence of standing water onsite through strict environmental controls and source reduction to avoid the creation of new breeding grounds. Such measures include repairing leaking pipes, dewatering of open excavations and effective drainage systems along access roads Control or Reduction of Individual Risk: <ul style="list-style-type: none"> Personal protection and behaviour modification measures e.g., awareness raising and education programmes, and mandating compliance with appropriate anti-malarial chemoprophylaxis for employees when recommended Reduce the potential for mosquito-human interactions in workforce accommodation, office 	Integrated malaria control, Prevention and treatment programme and compliance with this programme	Developer/Contractor/Health Specialist	Throughout construction	Noted in audit reports when relevant

Aspect	Activity	No.	Mitigation/Management Action	Measure of Effectiveness	Responsibility	Frequency	Reporting Requirements
			<p>space and other buildings through the use of screens at windows and doors, application of air conditioners and fans, the use of bed nets and other measures</p> <ul style="list-style-type: none"> • Ensure that the workforce has access to prompt, accurate and effective diagnosis and treatment while working on site or in remote areas • Develop and disseminate a malaria information booklet and training material for the workforce. These materials should be used as part of a new employee induction, as well as part of annual refresher training sessions on malaria <p>Limit Effect of Infection:</p> <ul style="list-style-type: none"> • Partnership and collaboration in community programs with key external stakeholders to ensure community collaboration and enhance program sustainability • Ensure availability of malaria treatment at all clinics used by the workforce and local communities. This should be achieved through a partnership with the respective Ministry of Health and / or relevant NGOs 				
	Management of STD's and sexual health	157.	ZRA and its Contractor will in partnership with local health officials and relevant NGOs, undertake information, education and communication campaigns around safe sexual practices and transmission of STIs and HIV/AIDS. These campaigns should make use of roadshows, radio and small group discussions.	Information presented at campaigns	Developer/Contractor	Throughout construction	Noted in audit reports when relevant
	Traffic management	158.	<p>The Contractor shall control the movement of all vehicles including that of his suppliers so that they remain on designated routes, are distributed so as not to cause an undue concentration of traffic and that all relevant laws are complied with. In addition, such vehicles shall be so routed and operated as to minimise disruption to regular users of the routes not on the Site.</p> <p>The vehicles of the Contractor and his suppliers shall not exceed a speed of 40 km/h on gravel or earth roads on Site and within the Project area. Tracking technology (GPS, speed-logging equipment, etc.) will be installed to review driver performance, and to identify drivers with a history of unsafe behaviour. Any violators may be subject to dismissal.</p>	Zero violations	Contractor	Throughout construction	Noted in audit reports when relevant
		159.	During construction, arrangements and routes for abnormal loads must be agreed in advance with the relevant authorities and the appropriate permit must be obtained for the use of public roads.	Transport permits in place as required	Contractor	Throughout construction	Noted in audit reports when relevant
		160.	The Contractor will ensure that Project drivers are qualified, trained to drive safely and have the required licenses.	All drivers to have the required licenses	Contractor	Throughout construction	Noted in audit reports when relevant
		161.	The Contractor will strictly enforce drug and alcohol policies in relation to Project drivers and undertake	Zero violations from testing	Contractor	Throughout construction	Noted in audit reports when relevant

Aspect	Activity	No.	Mitigation/Management Action	Measure of Effectiveness	Responsibility	Frequency	Reporting Requirements	
			regular and random testing of drivers and in response to suspicious behaviour or as spot checks.					
		162.	The Contractor will develop and implement an equipment and vehicle maintenance program. This programme will include measures to ensure that Project vehicles are suited to local environmental conditions. All vehicles to be maintained to international requirements.	Vehicle maintenance programme and record thereof	Contractor	Throughout construction	Noted in audit reports when relevant	
		163.	The Contractor will develop and maintain road and safety related signage.	Signage in compliance with traffic regulations	Contractor	Throughout construction	Noted in audit reports when relevant	
		164.	ZRA and the Contractor will establish an incident investigation procedure in the event that any transport related incident occurs. Based on the findings of those investigations, ZRA will review and revise health and safety procedures as necessary.	Incident investigation procedure	Contractor/Developer	Prior to construction	Noted in audit reports when relevant	
Occupational Health and Safety	Preparation and consumption of food	165.	The Contractor shall designate eating areas to the approval of the Engineer, which will be clearly demarcated. Sufficient bins will be present in this area. Any cooking on site will be done in a designated area with well-maintained cookers with fire extinguishers present.	Designated facilities as required	Contractor	At site establishment and throughout construction	Noted in audit reports when relevant	
	Working hours	166.	A limit on working hours and overtime will be implemented and will adhere with the Zambian and Zimbabwean legal requirements and industry good practice.	Limited working hours and clear procedures for overtime work	Contractor	Prior to construction	Noted in audit reports when relevant	
	Emergency preparedness	167.	The Contractor will at all times observe proper and adequate safety precautions on the site. Telephone numbers of emergency services, including the local firefighting service, shall be posted conspicuously in the Contractor's office near the telephone. In addition to the above, the Contractor is to develop a Fire Safety Method Statement, which must include measures that need to be taken in the event of a fire emergency on site. This method statement will need to link back to the Emergency Preparedness Plan referenced in <i>Section 4.5</i> .	Evidence of emergency numbers Fire Safety Method Statement	Contractor	Throughout construction	Noted in audit reports when relevant	
	Contractor management	168.	The ZRA and its Contractor will develop and implement an Occupational Health and Safety Method Statement.	Occupational Health and Safety Method Statement	Contractor	Throughout construction	Noted in audit reports when relevant	
	Grievances		169.	The Contractor will develop an internal grievance redress mechanism to ensure fair and prompt resolution of problems arising from the Project.	Employee grievance mechanism	Contractor	Throughout construction	Noted in audit reports when relevant
			170.	The grievance Redress mechanism will be publicly advertised by the Project to the workforce. It will be easily accessible by workers, free of retaliation and should allow anonymous complaints to be raised and addressed.	Proof of notification	Contractor/Developer	Throughout construction	Noted in audit reports when relevant
			171.	The grievance Redress Mechanism will be underpinned by the following principles and commitments: <ul style="list-style-type: none"> Implement a transparent grievance procedure, and disseminate key information to directly impacted stakeholders Implement and maintain a complaints register 	Employee grievance redress mechanism	Contractor/Developer	Throughout construction	Noted in audit reports when relevant

Aspect	Activity	No.	Mitigation/Management Action	Measure of Effectiveness	Responsibility	Frequency	Reporting Requirements
			<ul style="list-style-type: none"> Seek to resolve all grievances timeously Maintain full written records of each grievance case and the associated process of resolution and outcome for transparent, external reporting <p>The responsibility for resolution of grievances will lie with the ZRA and its Contractors.</p>				
	Training	172.	Health awareness training will be provided to all employees. This will include knowledge and awareness around how communicable diseases are transmitted, diseases to be aware of, their symptoms and the benefits of early treatment. Health awareness training should be provided as part of worker's induction with refresher courses provided annually.	Training material	Contractor	Throughout construction	Noted in audit reports when relevant
		173.	ZRA and its Contractor will develop and implement a Workforce Code of Conduct. This will include: <ul style="list-style-type: none"> Zero tolerance of illegal activities by all personnel Forbidding the use of prostitution; Forbidding the illegal sale or purchase of alcohol Forbidding the sale, purchase or consumption of drugs Forbidding gambling and fighting. 	Workforce code of conduct and compliance with this	Contractor	Throughout construction	Noted in audit reports when relevant
	Recruitment	174.	Pre-Employment screening measures will be developed and implemented for workers, which will cover appropriate diseases. Individuals found to be suffering from communicable diseases will be provided with treatment prior to mobilisation to site.	Proof of pre-employment screening	Contractor	Throughout construction	Noted in audit reports when relevant
	Provision of health facilities and treatment	175.	TB prevention measures will be implemented including free testing and free treatment for all personnel working on the Project.	Proof of pre-employment screening	Contractor	Throughout construction	Noted in audit reports when relevant
		176.	ZRA and its Contractor will ensure sufficient health services are available to meet the day-to-day needs of Project personnel without impacting on access to health care for communities. This will include the provision of a health clinic with trained medical personnel at staff townships or sites.	Health clinic and staff for employees	Contractor	Throughout construction	Noted in audit reports when relevant
		177.	ZRA will develop agreements with health clinics or hospitals that the Project intends to use. This will refer to care that cannot be treated at the in-house Project facilities. These agreements should include support to increase capacity (health personnel, equipment, drugs etc.) to ensure that there is no loss of access for community members.	Agreements with health facilities	Developer/Contractor	At site establishment	Noted in audit reports when relevant
	Emergency preparedness	178.	Develop an Emergency Preparedness Plan. In collaboration with the local and regional Government and local emergency providers and local health care facilities, the Emergency Preparedness Plan () will be developed. This will cover all incidents presenting risks to public safety and the affected communities in proximity to the various Project Sites and the environment. The Plan will: <ul style="list-style-type: none"> Be applicable to all contractors and subcontractors as well as local communities; 	Emergency Preparedness Plan	Developer	At site establishment	Noted in audit reports when relevant

Aspect	Activity	No.	Mitigation/Management Action	Measure of Effectiveness	Responsibility	Frequency	Reporting Requirements
			<ul style="list-style-type: none"> Consider access to health care, major incidences, exposure to hazardous materials, multiple casualty events, epidemics and pandemics Make provisions for awareness-raising activities and emergency response training to the communities that are considered to be at higher risk. <p>The Plan will provide a detailed procedure should an emergency evacuation of the staff townships, permanent townships and Project site be ordered. As part of ZRA's and its contractor's emergency preparedness, they will be required to have trained personnel and emergency equipment in place in the event of any emergency and all site personnel, including contractors, are to be trained in the appropriate responses for fire and accident emergencies.</p>				
		179.	ZRA and its Contractor will monitor the emergence of major pandemics through WHO alerts. If the WHO Pandemic Alert Scale reaches level 4 the Project will develop and implement the relevant Emergency Preparedness Plan.	Emergency Preparedness Plan	Contractor	Throughout construction	Noted in audit reports when relevant
	Maintenance of health facilities	180.	ZRA and its Contractor will maintain the health centres/hospitals that will be developed as part of the permanent staff townships.	No complaints received regarding inadequate services from employees	Developer/Contractor	Throughout construction	Noted in audit reports when relevant
	Accommodation	181.	ZRA and its Contractor will operate accommodation at staff townships in accordance with international good practice. This will include prevention of overcrowding, access to clean water and sanitation and enforcing high levels of food hygiene standards within the townships to minimise disease transmission. The Project will encourage the early reporting of illness and 'stop-work' when this occurs amongst food handlers.	No complaints received regarding inadequate services from employees	Developer/Contractor	Throughout construction	Noted in audit reports when relevant
	STD Management	182.	ZRA and its Contractor will develop a policy and management method statement to reduce the transmission of STIs, including HIV/AIDS. The strategy will: <ul style="list-style-type: none"> Make provision for awareness, counselling and testing for all Project personnel, including voluntary testing for STIs and HIV/AIDS as part of any health-screening program (workers will not be denied employment or discriminated against in any way based on their HIV status.) Provide support to workers to access treatment for HIV/AIDS through existing health facilities or NGO campaigns or programmes Ensure there is access to free condoms (including female condoms) at all worker sites and accommodation (including transit routes) to promote safe sexual practices Ensure that all Project personnel are given specific HIV and STI prevention training. This 	HIV/Aids Management Method Statement and effective implementation	Developer/Contractor/Health Specialist	Throughout construction	Noted in audit reports when relevant

Aspect	Activity	No.	Mitigation/Management Action	Measure of Effectiveness	Responsibility	Frequency	Reporting Requirements
			<p>should be given on induction and refresher training provided annually</p> <ul style="list-style-type: none"> In partnership with local health officials and relevant NGOs, undertake information, education and communication campaigns around safe sexual practices and transmission of STIs and HIV/AIDS 				
	Training	183.	Ensure that all Project personnel are given specific HIV and STI prevention training. This will be given on induction and refresher training. The Contractor and Subcontractors commitments to this training should be stipulated in the contracts with specific time allocations for this training per employee skills level being provided and as such committed to.	Training material and attendance registers	Developer/Contractor	Throughout construction	Noted in audit reports when relevant
	Contractor management	184.	<p>A contractor audit and supply chain management method statement and policy will be developed and implemented. All contractors and suppliers will be expected to sign agreements to comply with the standards it specifies. Failure to meet the standards will result in consequences up to and including termination of contract, to be decided on a case-by-case basis. The method statement will include requirements for:</p> <ul style="list-style-type: none"> All contractors to be audited on a quarterly basis for adherence to the relevant national laws and the Project's international OHS standards All contracts for primary and secondary contractors should specify OHS performance and monitoring in their contracts and should be required to action gaps in an agreed period All primary suppliers should be audited on a bi-annual basis for adherence to both national requirements and ZRA's OHS standards. Regular auditing should serve to monitor ZRA's primary supply chain and identify any significant changes or new risks arising Where significant health and safety risks are identified related to supply chain workers ZRA should introduce specific procedures and mitigation measures to address these risks over a specified time period. If risks are not addressed, ZRA should look to change the primary supply chain by selecting suppliers that comply with their OHS standards and national requirements <p>A central part of supply chain management should consider identifying potential risks related to significant safety incidents, damage to the environment or use of child or forced labour</p>	Audit and Supply Chain Management Method Statement and policy	Developer/Contractor	Throughout construction	Noted in audit reports when relevant
	Security	185.	With the possible exception of any security staff who may be required to be present overnight at the site office, no personnel will be permitted to live on the site. Security staff must be provided with heating and cooking facilities (in order that they do not need to	Approval of the Engineer and SHEQ Manager	Contractor	Throughout construction	Noted in audit reports when relevant

Aspect	Activity	No.	Mitigation/Management Action	Measure of Effectiveness	Responsibility	Frequency	Reporting Requirements
			light fires), and access to toilet facilities and communication equipment.				
		186.	The ZRA and its Contractor will develop a Security Management Method Statement that will set out the process for recruitment and management of security personnel. Management of security providers should be in line with the Voluntary Principles on Security and Human Rights. The Voluntary Principles guide companies in maintaining the safety and security of their operations within an operating framework that ensures respect for human rights and fundamental freedoms.	Security Management Method Statement and effective implementation	Contractor	At site establishment and throughout construction	Noted in audit reports when relevant
Social	Physical and economic displacement	187.	Compensation for the loss of land and other assets will have been paid in order to secure the land; the focus is now on the restoration of the livelihoods of affected people restored in accordance with the Resettlement Action Plan/Livelihood Restoration Plan.	Signed off agreements by households impacted by economic and/or physical displacement; proof of compensation payments /relocation	Developer/Resettlement Specialist	Prior to the displacement	RAP Reports and Proof of Payment/Replacement asset handover
	Livelihoods and ecosystem services	188.	The ZRA will communicate with affected stakeholders about the location of alternative fishing areas that will not be affected by the Project and will still be available to fishermen, and provide necessary compensation/transitional support if required as per RAP/LRP	Records of communication; and proof of agreements/compensation	Developer/Livelihood Specialist	Prior to the loss of access to fishing areas	Noted in audit reports when relevant
		189.	Compensation needs to be given to those businesses that are economically displaced as a result of impounding the river. A process for the identification and calculation thereof needs to be followed according to international best practise and is to consider: <ul style="list-style-type: none"> The appointment of qualified social and economic consultants to undertake further studies identifying businesses eligible for compensation, define the impact on these businesses as a result of the impoundment and developing a plan for the calculation of entitlements and implementation of the compensation process Compensation will need to be calculated on the basis of actual financial losses anticipated Compensation need not only be of monetary value and options should be explored in this regard Affected parties will be required to register to assist in the definition of eligibility. All claims made by affected parties will need to be investigated to determine validity A comprehensive record will be kept of the planning and implementation process 	Approved Livelihood Restoration Plan (LRP), supported by affected business	Developer/Resettlement Specialist	Prior to inundation	Noted in audit reports when relevant
	Downstream users	190.	A detailed Downstream Management Plan, including inventory and monitoring program of downstream users with livelihoods that partially or wholly depend on the river and who may be affected by water level (and quality) changes resulting from the Project.	Downstream user inventory and monitoring program as per RAP/LRP	Developer/Resettlement Specialist	At the commencement of construction activities	Downstream Management Plan Noted in audit reports when relevant

Aspect	Activity	No.	Mitigation/Management Action	Measure of Effectiveness	Responsibility	Frequency	Reporting Requirements	
In-migration		191.	ZRA and its Contractor will work in conjunction with relevant partners (e.g. health authorities, NGOs, development agencies) to develop information, education and communication campaigns around diseases and health practices related to sanitation and hygiene.	Materials from campaigns	SHEQ Manager/Contractor/Stakeholder Engagement Specialist	Throughout construction	Noted in audit reports when relevant	
		192.	ZRA and its Contractor will initiate discussions with the Zimbabwean and Zambian Health Authorities in order to plan for anticipated increased demands on local health facilities from the Project (during construction) as newcomers to the area.	Records of discussions with the Zimbabwean and Zambian Health Authorities	SHEQ Manager/Contractor/Stakeholder Engagement Specialist	At the commencement of construction activities	Noted in audit reports when relevant	
		193.	ZRA and its Contractor will support government initiatives that ensure local education's capacity to meet increased pressure on schools in the area.	Proof of support	SHEQ Manager/Developer/Contractor	Throughout construction	Noted in audit reports when relevant	
		194.	ZRA and its Contractor will lobby with relevant NGOs/government authorities for infrastructure improvements to support management of in-migrants. Agreement should be reached around designated areas for new migrant settlements and discourage informal settlement. The location of business and informal trading areas will also require consideration.	Records of discussion with NGOs and government authorities and proof of designated areas	SHEQ Manager/Contractor/Stakeholder Engagement Specialist	Throughout construction	Noted in audit reports when relevant	
		195.	ZRA and its Contractor will explore ways in which to support local policing if there is increased pressure on the limited resources as a result of the Project.	Records of discussions with local police	SHEQ Manager/Contractor	Throughout construction	Noted in audit reports when relevant	
		196.	ZRA and its Contractor will collaborate with Local and District Authorities to monitor in-migration rates.	Records of in-migration and monitoring reports for this	SHEQ Manager/Contractor	Throughout construction	Noted in audit reports when relevant	
		197.	ZRA will implement an employment policy forbidding informal labour hire.	Employment policy	SHEQ Manager/Contractor	Throughout construction	Noted in audit reports when relevant	
		198.	Ensure community awareness and safety in terms of Project operational areas, hazardous areas, and future development areas. This should prevent inappropriate and unsafe settlement near to Project activities.	Awareness materials	SHEQ Manager/Contractor	Throughout construction	Noted in audit reports when relevant	
		Community Benefits	199.	Destroyed trees should be made available to communities as fuel wood or as building resources, to reduce the demand for such resources from the natural habitats. This excludes vegetation in the area of inundation.	Notification of communities on record and proof of tree distribution	Contractor	Throughout construction	Noted in audit reports when relevant
		Employment of local labour		200.	The Contractor will establish a recruitment office in Livingstone, Zambia and Victoria Falls, Zimbabwe. The offices will disseminate information about potential job opportunities (and procurement contracts) and should also keep a database of available prospective employees, their skills levels and contact details. Workers will be preferentially recruited from this list whenever labour is required.	Local Employment Method Statement (Approved & Operationalized) Database, disseminated information and establishment of recruitment offices; monitoring reports	Contractor	At the commencement of construction activities
201.	No employment will take place at the entrance to the site. Only formal channels for employment will be used.			Verification of recruitment & hiring process	Contractor	Throughout construction	Noted in audit reports when relevant	
Community development		202.	The ZRA will engage with local stakeholders to manage expectations around the supply and distribution of water and electricity.	Records of communication	Developer/Stakeholder Engagement Specialist	Throughout construction	Noted in audit reports when relevant	

Aspect	Activity	No.	Mitigation/Management Action	Measure of Effectiveness	Responsibility	Frequency	Reporting Requirements
		203.	ZRA will support community-based and inter-village youth programmes based on Community Development Plan (CDP)	Demonstration of support	Developer/Stakeholder Specialist Engagement	Throughout construction	Noted in audit reports when relevant
		204.	ZRA will commit community investment funds to public health initiatives being implemented by regional/local Government and /or relevant NGOs as per CDP	Demonstration of support	Developer/Stakeholder Specialist Engagement	Throughout construction	Noted in audit reports when relevant
		205.	ZRA will support local school education initiatives by government and NGOs, based on local priorities and needs (as per CDP)	Demonstration of support	Developer/Stakeholder Specialist Engagement	Throughout construction	Noted in audit reports when relevant
Waste Water	Discharge and handling	206.	Hazardous waste should be handled at all times by licensed personnel. Additionally, all wastewater discharge points must be licensed as per national licensing requirements. Potential pollutants of any kind and in any form will be kept, stored, and used in such a manner that any escape can be contained and the water table not endangered. Water containing such pollutants as cements, concrete, lime, chemicals, fuels and hydrocarbons shall be contained and discharged into an impermeable storage facility for removal from the site or for recycling. This particularly applies to water emanating from concrete batching plants and concrete swills, and to runoff from fuel depots/workshops/truck washing areas.	Hazardous Substances Method Statement Contaminated Water Method Statement	Contractor	Throughout construction Method statement must be approved at start of contract	Noted in audit reports when relevant
		207.	Wash down areas shall be placed and constructed in such a manner so as to ensure that the surrounding areas are not polluted. The Contractor shall notify the Engineer immediately of any pollution incidents on Site. If construction areas are to be pumped of water (e.g. after rains), this water must first be pumped into a settlement area, and not directly into a natural ecosystem.	Hazardous Substances Method Statement Contaminated Water Method Statement	Contractor	Throughout construction Method statement must be approved at start of contract	Noted in audit reports when relevant
		208.	A Method Statement shall be required for all wash areas where hydrocarbon and hazardous materials, and pollutants are expected to be used. This includes, but is not limited to, vehicle washing, workshop wash bays and paint equipment cleaning. Wash areas for domestic use shall ensure that the disposal of contaminated "grey" water is sanctioned by the Engineer and SHEQ Manager.	Hazardous Substances Method Statement Contaminated Water Method Statement	Contractor/Engineer/SHEQ Manager	Throughout construction Method statement must be approved at start of contract	Noted in audit reports when relevant
Solid Waste	Waste management /removal/disposal	209.	The Contractor shall be responsible for the establishment of a waste control system (Solid Waste Management Method Statement) that is acceptable to the Engineer and SHEQ Manager, and a Method Statement is required in this regard. The Contractor shall keep detailed records of waste removed from site, together with proof of recycling or legal disposal at a registered landfill site (disposal certificates).	Solid Waste Management Method Statement	Contractor/Engineer/SHEQ Manager	Throughout construction Method statement must be approved at start of contract	Noted in audit reports when relevant
		210.	No refuse or waste material will be disposed of by burying or burning, unless previously licensed by ZEMA/EMA	Records / visual observations	Contractor	Throughout construction	Noted in audit reports when relevant

Aspect	Activity	No.	Mitigation/Management Action	Measure of Effectiveness	Responsibility	Frequency	Reporting Requirements
		211.	Litter and waste materials (excluding rubble and hazardous waste materials) shall be disposed of into scavenger- and weather-proof bins. The Contractor shall provide sufficient bins with lids on Site to store the waste produced on a daily basis. In order to facilitate recycling it is recommended that a number of bins be provided at each location, and that such bins be clearly marked according to the category of waste being recycled (e.g. paper, metals, plastics, glass etc.) Bins shall not be allowed to become overfull and shall be emptied a minimum of once daily. The waste may be temporarily stored on Site in a central waste area that is weatherproof and scavenger-proof, and which the Engineer has approved. The Contractor shall then remove the refuse collected from the working areas, from Site at least once a week. Any refuse not being re-cycled must be disposed of at a waste disposal facility.	Records / visual observations	Contractor	Throughout construction	Noted in audit reports when relevant
		212.	The Contractor shall ensure that waste and surplus food, food packaging and organic waste are not deposited by employees anywhere on the site except in refuse bins.	Records / visual observations	Contractor	Throughout construction	Noted in audit reports when relevant
		213.	Empty cement bags must be collected from the construction area by the end of every day and before rain events and shall be stored in bins that are either placed under cover or have been fitted with lids. This prevents the bags getting wet and the cement powder leaching into the environment.	Records / visual observations	Contractor	Throughout construction	Noted in audit reports when relevant
		214.	Petroleum, chemicals, and harmful and hazardous waste is to be stored in an enclosed and bunded area. The location of these sites is to be approved by the Engineer and the SHEQ Manager. This waste shall be disposed of at a registered hazardous waste disposal site. The Contractor shall submit copies of receipts from such waste disposal sites to the Engineer and SHEQ Manager as proof of proper disposal. Storage and disposal etc. is also controlled through other relevant legislation which must be complied with e.g. Zambian Occupational Health & Safety Act and Zimbabwean Occupational Safety and Health Bill.	Records / visual observations Waste and/or disposal certificates	Contractor/Engineer/SHEQ	Throughout construction	Noted in audit reports when relevant Records of waste and/or disposal certificates.
		215.	Any building rubble not being recycled (e.g. sent for crushing) or reused shall be removed from site to an approved landfill site as soon as it constitutes a practical load for removal and before temporary closure of the site. No plastics, shrink-wrap, paint buckets or any other debris that does not constitute clean building rubble, shall be stored at such stockpile sites.	Records / visual observations Waste and/or disposal certificates	Contractor	Throughout construction	Noted in audit reports when relevant Records of waste and/or disposal certificates.
		216.	In the event of material removed during trenching being excessive after backfilling or being unsuitable as overburden, the excess material must be removed from the site to a site agreed upon by the Engineer and SHEQ Manager and, where applicable, the necessary Zimbabwean and Zambian Authorities.	Records / visual observations Waste and/or disposal certificates	Contractor	Throughout construction	Noted in audit reports when relevant Records of waste and/or disposal certificates.

Aspect	Activity	No.	Mitigation/Management Action	Measure of Effectiveness	Responsibility	Frequency	Reporting Requirements
Training	Environmental awareness training	217.	Environmental awareness training sessions shall be run for all personnel on site for more than two days. Courses shall be run during normal working hours at a suitable venue provided by the Contractor. All attendees shall remain for the duration of the course and sign an attendance register on completion that clearly indicates participant's names, a copy of which shall be handed to the SHEQ Manager.	Environmental awareness training material and attendance register	Contractor/SHEQ Manager	Should take place within 7 days of arriving on site. Throughout construction	Register of attendees. Noted in audit reports when relevant
		218.	The environmental awareness training content must be approved by the SHEQ Manager.	SHEQ approval	Contractor/SHEQ Manager	Prior to construction Throughout construction	Noted in audit reports when relevant
		219.	Environmental awareness training must occur within seven days of commencement of work on site.	Proof of training	Contractor/SHEQ Manager	Should take place within 7 days of arriving on site. Throughout construction	Register of attendees. Noted in audit reports when relevant
		220.	Awareness programmes should not be limited to staff and contractors, but will include an outreach programme to prominent individuals and community organisations such as schools, youth groups, women's groups. Active steps being taken by ZRA to protect the environment and collaborate with local communities need to be publicised and promoted.	Attendance registers	Contractor/Developer/SHEQ Manager	Throughout construction	Noted in audit reports when relevant
		221.	The ZRA and its Contractor will introduce the Workforce Code of Conduct at the awareness training that will be adhered to by all Contractors and ZRA employees. This will increase worker-sensitivity to local norms and customs.	Workforce code of conduct	Contractor/Developer/SHEQ Manager	Throughout construction	Noted in audit reports when relevant
		222.	The Contractor will erect and maintain information posters for the information of all employees depicting actions to be taken to ensure compliance with aspects of the environmental and social mitigation measures. Such posters will be erected at the eating areas and any other locations specified by the Engineer.	Awareness posters	Contractor	Throughout construction	Noted in audit reports when relevant

The following monitoring programmes have been identified through the ESIA work undertaken to date. These, however remain subject to change on the basis of further planning and design work still to be undertaken and will require further development, updating and review of their effectiveness on an on-going basis throughout the Construction Phase of the Project. Those required for development during the Operational Phase of the Project are detailed in the Operation ESMP.

Key monitoring requirements have been identified through the ESIA process to monitor the environmental and social performance of the Project.

The overall objectives of monitoring are to:

- Ensure regulatory requirements are met;
- Verify predictions made in the ESIA by obtaining real time measurements;
- Ensure for continuous improvement and measures for non-compliance;
- Verify that mitigation measures are effective; and
- Provide early warning of potential unplanned for or unmitigated impacts.

Monitoring will be carried out by ZRA and its Contractors pursuant to their contractual obligations to undertake inspections, monitoring and reporting. The following four types of inspections and monitoring will be employed.

- **Inspections** planned and conducted on a regular basis to ensure that mitigation measures and commitments are properly maintained and implemented, and that specific management procedures are being followed (e.g. practices related to temporary waste storage and transport).
- **Receptor monitoring** undertaken to verify predictions made in the ESIA and to confirm that the activities at the site are not resulting in unacceptable impacts on people, wildlife or a deterioration in the quality of habitats, the Zambezi River system or infrastructure (e.g. monitoring mammal movements, monitoring aquatic ecology of the Zambezi River system and assessing disturbance to affected communities through a grievance redress mechanism); and periodic surveys of affected people/communities to assess compliance with social management measures (i.e. RAP/LRP, Local Employment Strategy, CDP, etc.).
- **Compliance monitoring** involving periodic sampling or continuous recording of specific environmental quality indicators or discharge levels to ensure compliance of discharges and emissions with Project standards (e.g. waste water discharges and noise monitoring) and review of regular monitoring reports describing progress on implementation of social management measures.

- **Auditing** to assess compliance of the Project activities with both regulatory and site management system requirements.

The results of the inspection and monitoring activities will be reported to ZRA on a weekly basis, or as required. Annual external environmental and social management auditing and progress reporting will also be undertaken.

5.1 *PHYSICAL MONITORING PLANS*

5.1.1 *Air Quality*

The overall objective for air quality management during construction of the BGHES is to preserve air quality levels to the extent that impacts on the closest and/or most affected receptors situated in the vicinity of the BGHES are minimised. Furthermore, a key objective is to keep local communities and regulators informed of activities (where required) and to respond quickly and effectively to issues and complaints.

Refer to *Table 5.1* for the monitoring specifics / requirements that will be monitored during the pre-construction & construction phase for air quality.

5.1.2 *Noise and Vibration*

The primary objective for noise and vibration management during BGHES construction is to minimise impacts on the closest and/or most affected noise sensitive receptors (NSR's) situated in the vicinity of the Project are minimised. Furthermore, a key objective is to keep local communities and regulators informed of activities (where required) and to respond quickly and effectively to issues and complaints.

Refer to *Table 5.1* for the monitoring specifics / requirements that will be monitored during the pre-construction & construction phase for noise and vibration.

5.1.3 *Surface and Groundwater*

Monitoring measures for surface and groundwater for during the pre-construction and construction phase are included in *Table 5.1*.

5.2 *BIODIVERSITY MONITORING PROGRAMMES*

5.2.1 *Taita Falcon Monitoring and Habitat Management*

The actual impact of the reservoir on the Taita Falcon population is unknown, and careful monitoring of the Taita Falcon population has been requested in the 1993 and 1998 studies, is listed as a requirement by the ZPWMA, and will be implemented by the ZRA. Taita Falcons are small and elusive birds and detecting their presence is a specialised task, which needs to be outsourced to competent ornithologists. The bird monitoring will not be restricted to Taita

Falcons but should include all raptors and Black Stork populations that depend on the same Batoka Gorge habitat and overlap in terms of the area of impact.

The Department of National Parks and Wildlife - Zambia and Zimbabwe Parks will collaborate with the ZFC and BirdWatch Zambia to be involved in all bird monitoring activities. The ZRA will support their continued involvement in monitoring and subsequent evaluation of data.

Flooding of the Batoka Gorge will result in the water surface being close to the level of some of the Taita Falcon nesting sites, and movement of boats on the reservoir for fishing or tourism purposes may present a disturbance to these birds. The required raptor monitoring programme needs to include an assessment of the various disturbance factors and an ongoing assessment of how these can be managed to avoid or minimise loss of the Taita Falcon population.

Development of a preconstruction baseline is described in the table above. Subsequent monitoring of Taita Falcon and other raptor nesting activity will be conducted twice a year, at times identified to be most suitable by ZFC and BirdWatch Zambia (refer also to monitoring of Rock Pratincole below). Monitoring will continue for 10 years into the operational phase of the BGHES. An assessment of the requirements for further monitoring will be made at that time.

Based on the results of monitoring and expert ornithological opinion, captive breeding programmes should be considered, whereby eggs are taken from nests, the young are reared and released back into their natural habitats, with financial support from the income generated by the hydropower scheme.

Refer to *Table 5.1* for detailed monitoring plan for Taita Falcon.

5.2.2 *Rock Pratincole Monitoring Programme*

A Rock Pratincole monitoring programme will be required for the stretches of the Batoka Gorge that are not inundated by the reservoir. Ornithologists involved in the activities to monitor and minimise impacts to raptors will be well placed to advise on the necessary monitoring procedures for Rock Pratincole.

Monitoring of Rock Pratincoles will be attached to the above monitoring of Taita Falcon activity and implemented by the same ornithological organisations. Rock Pratincole habitat consists of emergent boulders in rapid flowing water, and these birds are present only during the low flow season. Monitoring programmes will therefore be restricted to a seasonal window.

5.2.3 *Further Wildlife Monitoring*

The following additional monitoring programmes will be adopted, although such a Project should not be limited to these actions only:

- Monitoring of elephant abundance and movements through satellite tracking, applicable to the Zimbabwe component of the study area;
- General monitoring of wildlife populations, applicable to the Zimbabwe component of the study area;
- Evaluation of Problem Animal (such as crop raiding and livestock loss) incidents and explore means of addressing these without loss of the animals, applicable to the Zimbabwe component of the study area;
- Monitoring how crocodile populations adapt to impoundment of their habitat by the reservoir, applicable to both Zambian and Zimbabwean components of the study area;
- A bat monitoring programme tailored to the ecology of the bat species is required, which needs to assess a baseline state prior to filling of the reservoir and frequent monitoring thereafter (applicable to both Zambian and Zimbabwean components of the study area); and
- Assess the diversity of other small mammals, reptiles and amphibians, with emphasis on threatened, rare, endemic or large concentrations of species (applicable to both Zambian and Zimbabwean components of the study area).

Refer to *Table 5.1* for detailed monitoring plan for biodiversity.

5.2.4 *Monitoring and Management of Fisheries*

Requirements for the development of regulatory and control mechanisms by the fisheries authorities in both Zambia and Zimbabwe with involvement of the ZRA to prevent overfishing are highlighted in the table above.

Ongoing scientific monitoring of the health of the fisheries resource. The nature of this monitoring will be determined by the Zambian and Zimbabwean fisheries authorities.

5.2.5 *Downstream Monitoring*

An integrated social, ecological and hydrological monitoring programme will be required to assess the impacts of the hydropower scheme on the downstream stretches of the Zambezi River. This monitoring programme will need to include hydrological aspects as well as the state of ecological receptors. This should be implemented in the Pre-construction Phase and carry through construction to operation. The following aspects should be included (but not necessarily limited to):

- Water levels and flow;
- Water quality;
- Sediment availability and movements;
- Biomonitoring of aquatic macro-invertebrates;

- Fish communities and harvesting levels;
- Riparian vegetation;
- Crocodile populations and harvesting of eggs; and
- River dependant birds.

Water quality monitoring should be undertaken immediately downstream of the construction works on a weekly basis. Detailed parameters to be monitored are provided in *Annex D*.

5.3 SOCIAL MONITORING PROGRAMMES

The following social monitoring programmes are suggested:

- Post resettlement and livelihood restoration monitoring and evaluation (with attention paid to monitoring identified vulnerable segments of the Project-affected communities);
- Monitor the project area so as to prevent illegal encroachment;
- Monitor construction activities to ensure that the community is not negatively affected by the construction workforce and that the contractor abides by the rules;
- Monitoring and evaluation of contractor alignment with local employment and local content (procurement of goods and services) plans;
- Monitoring and evaluation of in-migration / out-migration;
- Outbreak of world pandemics through WHO alerts;
- Monitoring of construction activities in those areas that have been identified to be of high heritage significance;
- Monitoring of Community Development Programme effectiveness and understand the capacity of role-players to take over the responsibilities of operating these;
- Monitoring will include an annual tourism survey that focuses on collecting information from tourists as well as activity operators. The annual tourism survey will focus on data relating to tourist demographics and behaviour. Activity operator surveys will provide detailed information and opinion on trends in sales and on the current economic climate in terms of the demand for various activities in the study area;
- Park statistics (Victoria Falls National Park/Rainforest Park and Mosi-oa-Tunya National Park) will be monitored as these provide an indication of tourism trends;

- Regular, survey-based estimates of household income and employment in all sectors, including tourism and downstream water users will be collected throughout the study area. This should be monitored as an aggregate of household employment and income in order to monitor overall trends in prosperity of the area. Simply monitoring average household income does not account for people leaving or being attracted to the area; and
- Online travel sites, such as Trip Advisor, should also be monitored. These sites contain a wealth of information relating to tourist experiences and opinions. Tourists use these sites to rate their holiday experiences. Tourists are able to rate the location, accommodation and activities on offer and these ratings should be continuously recorded in order to monitor the trends.

Refer to *Table 5.1* for detailed monitoring plan for Social.

5.4

EMERGENCY PREPAREDNESS

The Emergency Preparedness Plan (refer to *Section 4.5*) will need to include monitoring aspects for inspections of response equipment and personal protection equipment. Moreover, this plan will need to put in place an implementable preventative maintenance programme that can be used to identify any upcoming maintenance required, as well as what preventative maintenance may potentially be required.

The plan will also include a programme for emergency response drills. These will include, but not limited to fire drills; flash flooding drills, dam failure drills; medical drills; chemical / fuel spill drills; and emergency evacuation drills.

5.5

MANAGEMENT OF NON-COMPLIANCE

Non-compliance includes failure to adhere to all elements included in the ESMP. The SHEQ Manager will monitor compliance with this ESMP on an ongoing basis throughout the lifecycle of the BGHES Project.

The SHEQ Manager may determine whether any additional monitoring activities are required to monitor compliance with this ESMP.

Should the SHEQ Manager determine that non-compliance may have occurred, he/she will conduct a review to determine whether the non-compliance is valid. If it is valid, then the SHEQ Manager will undertake an inquiry and determine if the non-compliance is serious and/or continuing. The SHEQ Manager will impose remedial and disciplinary measures to rectify the non-compliance.

Insights obtained from non-compliance will be used to inform whether re-training of employees is required and / or whether additional management and monitoring measures are required.

5.6

MONITORING PLAN

A specific monitoring plan to monitor both the implementation and effectiveness of this CESMP is provided in *Table 5.1* below.

Table 5.1 Monitoring Plan to Ensure the Implementation and Effectiveness of the Construction Management Plan

MONITORING AND INSPECTION METHODOLOGY	FREQUENCY	LOCATION OF MONITORING STATIONS	REPORTING SCHEDULE	RESPONSIBLE PARTY	OUTPUT	PERFORMANCE INDICATOR
Air Quality						
<p>A Method Statement will be compiled for air quality monitoring during the pre-construction and construction phase. The Method Statement will make provision for:</p> <ul style="list-style-type: none"> Periodic visual inspections of activities resulting in impact to air quality. Visual inspections will reflect the ethos of 'see it, own it', in terms of identifying and addressing significant air quality impacts. Where significant impacts are observed, these will be recorded and closed out by the SHEQ Manager. Regular inspections during the site preparation phase to review air and dust issues and dust suppression techniques altered as required. If significant dust complaints are received, passive monitoring of dust deposition upwind and downwind of key construction areas will be undertaken. Monitoring will be undertaken using an internationally recognised technique. 	Throughout construction. Monitoring data will be reviewed on a monthly basis.	Construction sites	Quarterly or as and when significant dust complaints are received.	Contractor	Air Quality Monitoring Report	<ul style="list-style-type: none"> Dust monitoring results compliant to performance criteria. Recommendations and corrective actions taken when dust generation or combustion sources are noted. Complaints arising from air quality emissions managed through the grievance redress mechanism.
Noise and Vibration						
<p>A Method Statement will be compiled for noise monitoring during the pre-construction and construction phase. The Method Statement will make provision for:</p> <ul style="list-style-type: none"> Monthly noise measurements with portable noise meter at the nearest noise sensitive receptor locations to key Project activities (viz. staff townships, quarries and active work sites). Inspection of vehicle/machinery/equipment maintenance records. Noise monitoring at nearest noise sensitive receptors if significant complaints received. 	Regular noise level checks will be carried out on a monthly basis during construction and when significant noise complaints are received.	At the nearest noise sensitive receptor locations to key Project activities	Quarterly or as and when significant noise complaints are received.	Contractor	Noise and Vibration Monitoring Report	<ul style="list-style-type: none"> Noise monitoring results compliant to performance criteria Noise Records. Recommendations and corrective actions taken when high audible incidents are noted. Complaints arising from excessive noise managed through the grievance redress mechanism.
Implement a vibration monitoring programme during activities resulting in vibration to ensure compliance with Zimbabwe and Zambia's vibration limits at the nearest structure/building. The vibration monitoring programme must be focused on identifying the effectiveness of the adopted vibration reductions measures. Vibration monitoring is the measurement of passing movements in the ground, using an instrument such as seismograph (or equivalent), which detects and records movement.	If piling/blasting or vibratory compaction activities will occur within 50 m of sensitive structures or if significant complaints are received during these construction activities	Construction blasting sites	Following each blasting activity (i.e. ad-hoc)	Contractor		<ul style="list-style-type: none"> Vibration monitoring results compliant to performance criteria Recommendations and corrective actions taken when vibration incidents are noted. Complaints arising from excessive vibrations managed through the grievance redress mechanism
Monitor adherence to blasting schedule and the number of complaints received relating to blasting.	Throughout construction	N/A	Following each blasting activity (i.e. ad-hoc)	Contractor		<ul style="list-style-type: none"> Number of complaints pertaining to blasting.
Surface and Groundwater						
Groundwater levels in private and community wells located within 1 km of Project water abstraction boreholes will be monitored on a quarterly basis.	Pre-construction to obtain a seasonal baseline for capturing multi-seasonal data and 1-yr post construction Quarterly	1 km of proposed water abstraction boreholes	Quarterly or as and when significant water complaints are received.	Contractor	Water Monitoring Report	<ul style="list-style-type: none"> Yield and water levels in private / community wells not affected.

MONITORING AND INSPECTION METHODOLOGY	FREQUENCY	LOCATION OF MONITORING STATIONS	REPORTING SCHEDULE	RESPONSIBLE PARTY	OUTPUT	PERFORMANCE INDICATOR
<p>Monitoring of surface- and groundwater quality will take place -</p> <ul style="list-style-type: none"> Groundwater - in private and community wells located within 1 km of proposed water abstraction boreholes, staff townships, and any areas where hazardous substances will be handled, e.g.: refueling stations, vehicle workshops. Surface water - in rivers, streams and dams located within 1 km downstream of Project activities including downstream of the dam wall, staff townships and any areas where hazardous substances will be handled, e.g.: refueling stations, vehicle workshops. <p>Surface and groundwater samples will be collected at least quarterly, twice during the wet season and twice during the dry season, in areas where Project activities are taking place and for one year thereafter. Samples will be analysed for a suite of analyses (refer to <i>Annex D</i>).</p>	Pre-construction to obtain a seasonal baseline for capturing multi-seasonal data and 1-yr post construction	1 km of proposed water abstraction boreholes In rivers, streams and dams located within 1 km downstream of Project activities, dam wall, staff townships and any areas where hazardous substances will be handled	Following each round of monitoring	Contractor		<ul style="list-style-type: none"> Water quality results compliant to performance criteria.
Biodiversity						
In order to address the seasonal baseline for capturing multi-seasonal data, aquatic biomonitoring will be conducted in all aquatic habitats supporting flowing water that are affected by the BGHES. Established SASS5 aquatic monitoring protocols will be applied for monitoring the riparian vegetation, monitoring of invertebrates and for monitoring fish populations. Data will be consolidated to develop comprehensive assessments of the Present Ecological State of aquatic ecosystems. Preconstruction Aquatic Ecology baselines will be established and compared against data within the ESIA. Post construction Aquatic Ecology baselines will be established and compared against data from the preconstruction baselines.	Pre-construction to obtain a seasonal baseline for capturing multi-seasonal data and 1-yr post construction	All aquatic habitats supporting flowing water that are affected by the BGHES	1 year prior to construction and 1 year during	Appointed Aquatic Ecologist	Aquatic Ecology Baseline Aquatic Monitoring Protocol	No deterioration in aquatic present ecological state attributed to construction of the BGHES
Monitoring of the Taita Falcon and their potential nesting sites will be undertaken prior to the construction of the dam and its associated infrastructure.	Pre-construction to obtain a seasonal baseline for capturing breeding and non-breeding seasons	The entire length of the Batoka Gorge (From Victoria Falls to 10 km downstream of the Dam Wall site)	Reporting post monitoring	Appointed Biodiversity/ Avifauna Specialist Department of National Parks and Wildlife - Zambia Zimbabwe Parks and Wildlife Management Authority Zimbabwe Falcon Club BirdWatch Zambia	Taita Falcon Breeding and Nesting Baseline	No deterioration in avifauna present ecological state attributed to construction of the BGHES
The success of relocated of flora and fauna that are moved from the inundation area and other construction sites relating to the dams to be recorded, together with supporting data on species identification, date of removal, biometric information (height, diameter, weight etc.) and equipment used. This process will need to be undertaken in close collaboration with the relevant Wildlife Authority.	Monthly during construction following relocation of flora and fauna	Inundation area as well as all other construction sites	Monthly	Contractor Department of National Parks and Wildlife - Zambia Zimbabwe Parks and Wildlife Management Authority		Success of transplanting programmes and feedback from Department of National Parks and Wildlife -Zambia Zimbabwe Parks and Wildlife Management Authority
Regular visual inspections of identified weeds and pest species will be conducted by the Contractor.	Ad-hoc Alien invasive species inspections	In locations where land clearance has been experienced, including Dam and associated infrastructure footprint. The focus will be on locations representative of the worst affected areas.	Reporting for the BGHES record keeping should follow upon completion of each ad-hoc monitoring survey.	Contractor	Monitoring Report	Prevention and management of alien species
Regular monitoring of wildlife movement through the construction phase will be undertaken to ensure that both sensitive and problem flora and fauna are managed effectively. Should the removal of fauna be required (problem animals, immediate action is required.	Ad-hoc as well as monthly inspections as necessary	Throughout the dam and associated infrastructure construction footprint	Reporting should occur as and when incidences of problem animals	Contractor Zimbabwe Wildlife Authorities	Monitoring Report	Prevention and/or successful management of problem animals

MONITORING AND INSPECTION METHODOLOGY	FREQUENCY	LOCATION OF MONITORING STATIONS	REPORTING SCHEDULE	RESPONSIBLE PARTY	OUTPUT	PERFORMANCE INDICATOR
<ul style="list-style-type: none"> Routine inspections of undisturbed areas by the Contractor to identify any evidence of vegetation disturbance, weed infestation and fire management issues. Routine inspections of undisturbed areas by the Contractor to identify any evidence of habitat disturbance or feral pest presence. During construction, the SHEQ Manager will monitor site clearing to ensure that: <ul style="list-style-type: none"> Areas to be cleared are clearly defined; There is no unauthorised disturbance of the surrounding habitat area; and Where necessary, an animal retrieval program is implemented. 	Ad-hoc as well as monthly inspections as necessary	Undisturbed areas as well as all construction sites and their immediate surrounds	Reporting for BGHES record keeping should follow upon completion of each ad-hoc monitoring survey.	Contractor	Monitoring Report	No evidence of disturbance
<ul style="list-style-type: none"> Regular inspections will be undertaken during the construction period for subsidence, presence of weeds, re-vegetation success and stability in the dam and associated construction sites Until regrowth is established, significant (e.g. riparian zones) areas and any seeded areas will be monitored regularly to ensure growth and if necessary appropriate reapplication of seed will be carried out. The success of restoration will be assessed by comparing the percentage cover and species diversity on the construction area with that of adjoining land. Monitoring will also include an assessment of the effectiveness of weed control measures. The process of monitoring and rehabilitation will only conclude when the site becomes stable. 	<ul style="list-style-type: none"> Bi-annual and ad-hoc inspections or when flairs in alien species are recorded Rehabilitation will occur following the completion of each construction activity, where rehabilitation has been planned 	All construction areas	Reporting for BGHES record keeping should follow upon completion of each ad-hoc monitoring survey.	Contractor/Rehabilitation Specialist	Rehabilitation Monitoring Report	Successful Rehabilitation of construction sites
Land Acquisition and Resettlement						
<p>Internal monitoring system to track and report on:</p> <ul style="list-style-type: none"> Progress against the detailed RAP implementation schedule and key performance indicators. Review of land/livelihood related grievances submitted including analysis of trends, which may require program adjustments. Stakeholder engagement milestones achieved. 	Monthly progress reporting		Monthly	SHEQ Manager	Monitoring report	<p>KPIs to be reviewed and finalized by Social Team:</p> <ul style="list-style-type: none"> Number of affected individual household sign-offs completed; Number of affected households receiving full cash compensation entitlements; Number of replacement land plots acquired and physically displaced people adequately re-housed; Number of vulnerable households identified and provided with assistance Livelihood restoration measures initiated and completed.
Cultural Heritage						
Monitor progress and effectiveness of Cultural Heritage Method Statement	Monthly progress reporting		Monthly	SHEQ Manager	Monitoring report	<ul style="list-style-type: none"> Number of chance finds Number of chance find procedures successfully executed Number of areas of high heritage significance protected through construction

MONITORING AND INSPECTION METHODOLOGY	FREQUENCY	LOCATION OF MONITORING STATIONS	REPORTING SCHEDULE	RESPONSIBLE PARTY	OUTPUT	PERFORMANCE INDICATOR
Local Employment						
Monitor progress and effectiveness of Local Employment Method Statement	Monthly progress reporting		Monthly	SHEQ Manager	Monitoring report	<ul style="list-style-type: none"> To be developed and confirmed as part of preparing Local Employment Plan
Local Procurement						
Monitor progress and effectiveness of Local Procurement Method Statement	Monthly progress reporting		Monthly	SHEQ Manager	Monitoring report	<ul style="list-style-type: none"> To be developed and confirmed as part of preparing Local Procurement Plan
Community Development						
Monitor progress and effectiveness of Community Development Plan, and capacity of role-players to take over program responsibilities	Monthly progress reporting		Monthly	SHEQ Manager/	Monitoring report	<ul style="list-style-type: none"> To be developed and confirmed as part of preparing Community Development Plan
Project-induced In-migration						
Monitor progress and effectiveness of implementing the Project-induced In-migration (PIIM) Management Method Statement	Monthly progress reporting		Monthly	SHEQ Manager	Monitoring report	<ul style="list-style-type: none"> To be developed and confirmed as part of preparing PIIM Plan
Community Health and Safety						
<ul style="list-style-type: none"> Monitor progress and effectiveness of implementing Community Health and Safety Method Statement Monitor outbreak of world pandemics through WHO alerts Monitor construction activities to ensure that communities are not negatively affected by the construction workforce and that the contractor abides by the health and safety rules 	Monthly progress reporting		Monthly	SHEQ Manager	Monitoring report	<ul style="list-style-type: none"> To be developed and confirmed as part of preparing Community Health and Safety Plan
Economic Impact						
<ul style="list-style-type: none"> Undertake regular economic survey in Project-affected communities and compare against pre-project baseline Conduct annual tourism survey Monitor national park statistics Monitor Trip Advisory 	Annual progress reporting		Annually	SHEQ Manager	Monitoring report	<ul style="list-style-type: none"> To be developed and confirmed as part of economic impact monitoring

Audits will be carried out internally by ZRA to ensure compliance with regulatory requirements as well as their own HSE standards and policies. The frequency of audits will be risk based and will vary with the stage of the Project (more frequent in the early stages of the Project) and will depend on the results of previous audits. Audits to be conducted will also cover the contractor self-reported monitoring and inspection activities. The audit shall be performed by qualified staff and the results shall be communicated to the SHEQ Manager.

The audit will include a review of compliance with the requirements of this CESMP and include, at minimum, the following:

- Completeness of HSE documentation, including planning documents and inspection records;
- Review of the contractors plans, method statements, temporary works designs and arrangements specified in the contract documents;
- Conformance with monitoring requirements;
- Efficacy of activities to address any non-conformance with monitoring requirements; and
- Training Activities and record keeping.
- Completion audit following RAP/LRP implementation

The following is recommended for the frequency of auditing activities:

- Daily and weekly inspections to be undertaken by the SHEQ Manager as required;
- Monthly internal audits of compliance to be undertaken and reported on. Reports to be forwarded to Local and District Authorities as required; and
- Any auditing requirements prescribed by the regulatory authorities of Zambia and Zimbabwe and financial/lending institutions.

The ZEMA and EMA hold the general responsibility for approval of the BGHES's environmental license application and verifying that applicable environmental and social commitments included in this CESMP are adhered to during Project implementation. The ZEMA and EMA will remain directly involved in the Project as responsible monitoring agents, and will evaluate auditing and compliance documentation submitted to them.

This *Section* includes an estimate of the costs of implementing the BGHES management measures included in the CESMPs and OESMP and associated monitoring, including all capital, recurrent operating and training cost estimates.

It is important to note that -

- The cost estimate presented in this *Section* is split into the cost for the construction phase of the BGHES (which includes any pre-construction management measures), assuming a 7 year construction period, and the Net Present Value (NPV) cost estimate for a single year of operation.
- The costs estimates associated with physical and economic displacement must be regarded as high-level estimates for now. These cost estimates are based on previous benchmark resettlement costing estimates previously undertaken by ERM for a number of resettlement projects in Africa, and is informed by the limited fieldwork undertaken for development of the Project RPFs. Actual costs for resettlement will need to be confirmed during detailed resettlement action planning.
- The cost estimates provided in this *Section* do not provide estimates for implementing management measures (including compensation) for impacts to the tourism industry. Such costs estimates would need to be provided through an updated tourism study.
- The cost estimate does not make provision for biodiversity offset. The feasibility of available options for an offset, including consideration of a compensatory offset needs to be investigated. The IFC PS6 (paragraph 10) requires external specialist input into the offset design and implementation, but is beyond the scope of this ESIA.

The total estimated cost for implementation of environmental and social management commitments (including monitoring) is estimated at **US\$ 30,555,000** for during the construction phase and **US\$ 1,258,000** per year for during the operational phase (assumed at NPV) (refer to *Table.6.1*).

Table.6.1 *Costs of Social and Environmental Management*

Management Aspect	Estimated Cost (US\$) for during the Construction Phase ⁽¹⁾	Estimated Annual Cost (US\$) for during the Operational Phase ⁽²⁾
<u>Air Quality Management</u>	155 000	5 000
Implementation of management measures (<i>watering, covering of stockpiles etc.</i>)	105 000	0
Monitoring, auditing and reporting	50 000	5 000
Training	0	0
<u>Noise and Vibration Management</u>	220 000	15 000
Implementation of management measures (<i>silencing devices, communication of blasting schedule to communities, etc.</i>)	150 000	0
Monitoring, auditing and reporting	60 000	10 000
Training	10 000	5 000
<u>Soil Erosion Management</u>	610 000	40 000
Implementation of management measures (<i>installation of sediment basins, stabilization of cleared areas, erosion control systems, etc.</i>)	560 000	30 000
Monitoring, auditing and reporting	50 000	10 000
Training	0	0
<u>Surface Water and Groundwater Management</u>	210 000	15 000
Implementation of management measures	100 000	0
Monitoring, auditing and reporting	100 000	10 000
Training	10 000	5 000
<u>Dangerous Good and Hazardous Substances Management</u>	280 000	40 000
Implementation of management measures (<i>storage of corrosive / hazardous substances, clean-up procedures for spills, purchase and maintenance of spill kits, etc.</i>)	250 000	30 000
Monitoring, auditing and reporting	15 000	5 000
Training	15 000	5 000
<u>Waste Management</u>	875 000	150 000
Implementation of management measures (<i>development of waste inventory, systems to ensure sorting and segregation of wastes, waste storage receptacles, etc.</i>)	800 000	100 000
Monitoring, auditing and reporting	50 000	40 000
Training	25 000	10 000
<u>Terrestrial Ecology Management</u>	1 190 000	95 000
Implementation of management measures (<i>avifauna, loss of habitat, transmission lines</i>)	1 000 000	50 000

Management Aspect	Estimated Cost (US\$) for during the Construction Phase ⁽¹⁾	Estimated Annual Cost (US\$) for during the Operational Phase ⁽²⁾
Monitoring, auditing and reporting	130 000	25 000
Training	60 000	20 000
<u>Aquatic Ecology Management</u>	685 000	115 000
Implementation of management measures (fisheries management, eutrophication and aquatic weed control)	500 000	80 000
Monitoring, auditing and reporting	150 000	30 000
Training	35 000	5 000
<u>Revegetation and Rehabilitation Management</u>	470 000	70 000
Implementation of management measures (rehabilitation, alien plant control)	400 000	60 000
Monitoring, auditing and reporting	50 000	5 000
Training	20 000	5 000
<u>Physical and Economic Displacement Management</u>	23 675 000	160 000
Implementation of management measures (Resettlement Action Planning and Implementation, compensation agreements, payment of compensation, restoration of livelihoods and ecosystem services)	23 500 000	100 000
Monitoring, auditing and reporting	140 000	50 000
Training	35 000	10 000
<u>Cultural Heritage Management (excluding grave relocation)</u>	95 000	22 000
Implementation of management measures (pre-construction surveys, water reconnaissance, development of chance find procedure and cultural heritage management method statement)	80 000	20 000
Monitoring, auditing and reporting	10 000	0
Training	5 000	2 000
<u>Community Health and Safety Management</u>	630 000	130 000
Implementation of management measures (PIIM Management Method Statement, recruitment strategy, traffic and road accidents management, community investment funds to public health and education (through existing structures), disease prevention planning, health baseline study, engagement with communities)	500 000	100 000
Monitoring, auditing and reporting	100 000	20 000
Training	30 000	10 000
<u>Traffic Management</u>	Included in Community Health and Safety Costs	
<u>Occupational Health and Safety Management</u>	1 000 130 000	68 000
Implementation of management measures (Occupational Health and Safety Method Statement, catering management, site safety, hygiene)	1 000 000 000	50 000
Monitoring, auditing and reporting	100 000	10 000

Management Aspect	Estimated Cost (US\$) for during the Construction Phase ⁽¹⁾	Estimated Annual Cost (US\$) for during the Operational Phase ⁽²⁾
Training	30 000	8000
Local Employment Management	590 000	135 000
Implementation of management measures (<i>local employment method statement, skills audit, recruitment and retention program and policy, employment advertising</i>)	400 000	100 000
Monitoring, auditing and reporting	40 000	10 000
Training (including capacity building & transitional planning)	150 000	25 000
In-migration Management	Included in Community Health and Safety Costs	
Community Development Management (excluding the cost of CSI initiatives)	210 000	50 000
Implementation of management measures (<i>engagement with local stakeholders re provision of services, support of existing women/youth/vulnerable groups programmes</i>)	100 000	30 000
Monitoring, auditing and reporting	30 000	10 000
Training	80 000	10 000
On-going Stakeholder Engagement / Grievance Redress Mechanism	460 000	68 000
Implementation of management measures (<i>public participation, management of grievances</i>)	400 000	50 000
Monitoring, auditing and reporting	40 000	10 000
Training	20 000	8 000
Other Social Monitoring (monitoring of downstream water users)	200 000	80 000
Monitoring, auditing and reporting	200 000	80 000
Dam Safety	Cots to be included as part of engineering studies	
TOTAL	30 555 000	1 258 000

(1) Assumes a period of 7 years for the construction phase.

(2) Annual operational costs are assumed at the Net Present Value (NPV).

Annex A

Grievance
Mechanism

Redress

Table 1.1 **Definition of Key Terms**

Term	Definition
Affected Party(ies)	Stakeholders who are affected by the company or operation, both positively and negatively. Within this it is possible to distinguish between those that are directly affected and indirectly affected by the company or operation.
Environmental and Social Impact Assessment	Process of evaluating and addressing potential social and environmental impacts resulting from ZRA’s Project and identifying any mitigation or corrective measures that will enable the project to meet the requirements of the World Bank Operational Standards, IFC Performance Standards and applicable Zambian and Zimbabwean laws and regulations.
Grievance	An issue, concern, problem, or claim (perceived or actual) that an individual or community group wants a company or contractor to address and resolve.
Grievance Database	System for logging and monitoring all grievances received, including any records of communication/consultation and details of grievance settlement.
Facilities / Operation(s)	A location or activity that is operated by ZRA or its contractors for the purpose of the Project. Locations could include the dam, construction camps, permanent villages, power houses, switchyard, access roads transmission lines, and offices including corporate head offices etc.
Records of communication / consultation	Records of communication / consultation may include key e-mails, letters, newsletters, memorandums, complaints, opportunities for improvement, records of distribution/attendance, records of formal and informal meetings and records of commitments.
Stakeholder	Persons or groups that are directly or indirectly affected by a project as well as those that may have interests in a project and/or the ability to influence its outcome, either positively or negatively. This can refer to shareholders, lenders, employees, communities, industry, governments and international third parties.
Stakeholder engagement	An umbrella term encompassing a range of activities and interactions between ZRA and stakeholders (two way communication) over the life of a project that are designated to promote transparent, accountable, positive, and mutually beneficial working relationships.
Vulnerable Groups	Individuals or groups within the project area of influence who could experience adverse impacts more severely than others based on their vulnerable or disadvantaged status. This vulnerability may be due to an individual's or group's ethnicity, gender, language, religion, political views, dependence on natural resources, sickness or disability or other factors.

1 GRIEVANCE REDRESS MECHANISM

1.1 INTRODUCTION

The Zambezi River Authority (ZRA) is a statutory body and was established in 1987. It is jointly and equally owned by the Governments of Zambia and Zimbabwe. It is responsible for overseeing the development of the Zambezi River, which runs through the two countries. The ZRA, alongside the Governments of Zimbabwe and Zambia, is proposing to develop the Batoka Gorge Hydro-Electric Scheme (BGHES) on the Zambezi River at Batoka Gorge.

The BGHES will provide up to 2,400 MW. It will help the Governments of Zambia and Zimbabwe to address power shortages being faced by the two countries and the region as a whole.

The proposed BGHES is anticipated to impact both directly and indirectly, positively and negatively on communities in the Project area and upstream and downstream of the proposed scheme. These impacts can potentially affect the lives of people living and working in these communities, thus giving rise to grievances. These potential grievances may relate to any aspect of the Project. They might be felt and expressed by a variety of parties including individuals, groups, communities, entities, or other parties affected or likely to be affected by the social or environmental impacts of the Project.

1.2 PURPOSE

The purpose of this Grievance Redress Mechanism is to outline the Zambezi River Authority's (ZRA) approach to accepting, assessing, resolving and monitoring grievances from those affected by ZRA's, and its Contractors', activities in relation to the BGHES. The aim is to identify and manage grievances from individual stakeholders or stakeholder groups. Timely redress or resolution of such grievances is vital to ensure successful implementation of the project

Grievances can encompass minor concerns as well as serious or long-term issues. They might be felt and expressed by a variety of parties including individuals, groups, communities, entities, or other parties affected or likely to be affected by the social or environmental impacts of the Project. It is essential to have a robust and credible mechanism to systematically handle and resolve any complaints that might arise in order that they do not escalate and present a risk to operations or the reputation of the company (nationally or internationally). If well-handled, an effective grievance redress mechanism can help foster positive relationships and build trust with stakeholders.

This Grievance Redress Mechanism has been considered in parallel to the Stakeholder Engagement Plan (SEP) (refer to *Annex B* of the main ESIA

document) due to the inter-relationship between these two planning mechanisms. It has been designed to meet the legal requirements of both Zambia and Zimbabwe and the requirements of the International Finance Corporation (IFC) in relation to grievance management.

The mechanism for addressing employee grievances is not addressed through this mechanism, which is solely to manage the interface with external stakeholders.

1.3 *SCOPE*

This Grievance Redress Mechanism will be applied to stakeholder complaints and grievances, perceived or actual, which relate to the activities of the ZRA and its Contractors' undertaken in relation to the BGHES.

A complaint or grievance is an issue, concern, problem, or claim (perceived or actual) that an individual stakeholder or community group has related to ZRA and its contractors' operations and activities. The mechanism does not impede access to judicial or administrative resolutions.

1.4 *APPLICATION*

This Grievance Redress Mechanism provides guidance to all ZRA employees and Contractors on receiving, registering, assessing and resolving community complaints or grievances emanating from ZRA's operations and activities in relation to the BGHES. The fundamental objective of this mechanism is to:

- Provide a predictable, transparent, and credible process to all parties for resolving grievances, resulting in outcomes that are seen as fair, effective, and lasting;
- Build trust as an integral component of broader community relations activities; and
- Enable more systematic identification of emerging issues and trends, facilitating corrective action and pre-emptive engagement.

To maximise the effectiveness of the Grievance Redress Mechanism, ZRA shall uphold the following values during implementation and operation of the system:

- Commitment to fairness in both process and outcomes;
- Freedom from reprisal for all involved parties – within ZRA and in the external stakeholder group;
- Clear operating rules, and accountability;

- Validity of all complaints submitted;
- Culturally accessible and applicable;
- Accessible to vulnerable groups of stakeholders; and
- Confidentiality if requested.

1.5 NOTIFICATION

ZRA (Chief Executive) will proactively inform affected communities and the wider stakeholder group of the details of the Grievance Redress Mechanism. This will include information about where people can go and who they can talk to if they have a grievance. This information shall be widely and regularly publicised, throughout the duration of the public consultation exercise, through meetings and the distribution of fliers.

ZRA will provide the information in a format and languages that are readily understandable by the local population and/or orally in areas where literacy levels are low during routine stakeholder engagement.

1.6 ROLES, RESPONSIBILITIES AND RESOURCES

Implementation of the Grievance Redress Mechanism for the BGHES will be the ultimate responsibility of the Grievance Manager. The Grievance Manager will be supported by a wider team. The various roles of the ZRA Grievance Management Team are detailed below:

Grievance Manager

The Grievance Manager will:

- Implement the Grievance Redress Mechanism procedure and management system providing guidance on solutions to complaints and grievances in consultation with the relevant departments and ensure consistency of redress for all grievances received in relation to the BGHES.
- Promote the Grievance Redress Mechanism to maintain momentum and ensure company wide and community commitment to, and understanding of, its implementation and operation.
- Involvement in the investigation of grievances and the agreement of redress as well as overseeing interaction between various ZRA Departments and contractors as well as the senior managers as required.

All ZRA Departments and Contractors

ZRA Departments and Contractors will:

- Receive and acknowledge any issue, concern, complaint or grievance from the community, verbally or in writing. They will record the issue and report it to the Grievance Manager in compliance with the Grievance Redress Mechanism procedure.
- Involvement in the investigation of grievances as required depending on the nature and severity of the grievance and as directed by the Grievance Management team.

ZRA Chief Executive

The ZRA Chief Executive will:

- Ensure that this Grievance Redress Mechanism procedure is applied through all ZRA and Contractor departments and levels that are undertaking activities related to the BGHES.
- Apply necessary controls to minimise risks that could result in stakeholder grievances.
- Contribute to the resolution and sign off of any grievances which have international repercussions.

The following resources will also need to be in place:

- An auditable system for receipt, recording and tracking of the process (for example a grievance log, database etc.) shall be in place.
- Dedicated budget for resourcing management of Grievance Redress Mechanism and addressing grievances through financial or in-kind compensation as and when needed.

1.7

THE GRIEVANCE PROCESS

A Grievance Redress Mechanism must be a simple process whereby stakeholders can submit their complaints free of charge and, if necessary, anonymously or via third parties. It should allow complaints to be submitted in more than one format.

The following steps outline the process that may be followed to resolve a grievance. This process is presented in a diagram in *Figure 1.1* and all grievance forms are contained in *Appendix A*.

Figure 1.1 Grievance Process

Process	Description	Time
<p>1. Receive and Log Grievance</p>	<ul style="list-style-type: none"> • Face to face meeting with Stakeholder • Phone, fax, letter or email • Recorded by ZRA staff • Completion and submission of grievance form • Record grievance in Grievance Form and log on Grievance Database 	1 day
<p>2. Acknowledge Grievance</p>	<ul style="list-style-type: none"> • Receipt of grievance acknowledged through appropriate communication medium, but to be recorded in writing 	5 days
<p>3. Assess and Investigate</p>	<ul style="list-style-type: none"> • ZRA to assess and assign grievance significance • Consult with relevant parties • May require site visits and discussions with other stakeholders 	7 days
<p>4. Grievance Resolution</p>	<p>Identify further action required Response provided to complainant including, if necessary an indication of additional time and resources required to resolve grievance</p>	28 days after receipt of grievance
<p>5. Sign-off</p>	<ul style="list-style-type: none"> • Confirm with complainant that grievance can be closed, or determine what follow-up is necessary. • If the grievance is to be closed, grievance sign-off is required 	37 days after receipt of grievance
<p>6. Monitor</p>	<ul style="list-style-type: none"> • Record final sign-off of grievance according to significance • If grievance cannot be closed return to step 2 to re-assess or recommend whether third-party arbitration is necessary 	37 days – 3 months, dependent on significance

The process of reporting a grievance should be easily accessible and un-intimidating to any stakeholder. The preferable channels for reporting grievances can be discussed with the community as part of community engagement.

Following the establishment of the channels above, the method for addressing grievances is systematic and is divided into six key steps. These are as follows:

- Step 1: Receive and log grievance;
- Step 2: Acknowledge grievance;
- Step 3: Assess and Investigate;
- Step 4: Grievance Resolution;
- Step 5: Sign-off on grievance; and
- Step 6: Monitor.

1.7.1 *Step 1: Receive and Log Grievance*

Grievances can be submitted in writing, telephonically or presented verbally to the Grievance Manager using the following details:

Name: The Project Manager – BGHES

Phone number: +260 211 228401/2, +260 211 227970/1 or +260 211 238665

Email: zaraho@coppernet.zm and Batoka@zaraho.org.zm

Address: Kariba House, 32 Cha Cha Cha Road, P.O Box 30233, Lusaka, Zambia.

The grievance is received by the ZRA or a Contractor representative and is forwarded to the Grievance Manager.

All grievances shall be logged using the Stakeholder Grievance Form (*Appendix A*). ZRA will log, document and track all grievances received within the secure ZRA grievance database system (refer to *Appendix B* for an example of a grievance database). Grievances shall be assigned a case number and records of communication/consultation shall all be attached with the relevant entry and filed. The database shall be monitored regularly for recurring grievances so that appropriate mitigation can be developed. Refer to *Box 1.1* for tips on receiving grievances. As a minimum the following information shall be recorded:

- Case number;
- Complainant's name and contact details; ⁽¹⁾
- Date of complaint;
- Details of complaint;
- History of other complaints / queries / questions (if known);
- Resolutions discussed and agreed with the party(ies) in question;
- Actions implemented (including dates); and
- Outcome of the actions implemented.

(1) Name and contact details are necessary for interaction around the resolution of the grievance. Anonymous submissions will be permitted, but the party submitting should understand that direct response will not be possible.

Box 1.1

Tips for Receiving a Grievance

- Regardless of who receives the grievance, it needs to be forwarded to Grievance Manager for attention.
- The grievance redress mechanism should make it possible to lodge a grievance in any appropriate format (written, verbal, telephonic, email, post etc.). Consideration should be given to capturing concerns raised informally or indirectly (e.g., through perception studies, media reports, social media, etc.).
- It is important that the process is easily accessible and not intimidating to stakeholders.
- Regardless of the form of the complaints, all need to be addressed with the same sincerity and seriousness.
- The Grievance Manager will be required to be in touch with the complainant at least once per month to provide feedback on the grievance.

1.7.2

Step 2: Acknowledging Receipt of a Grievance

ZRA shall acknowledge receipt of any grievance as soon as possible, but up to seven days from the date it was submitted and shall inform the complainant about the timeframe in which a response can be expected. A Grievance Receipt Form (*Appendix A*) shall be signed and a copy provided to the complainant. Refer to *Box 1.2* for tips on acknowledging grievances.

Box 1.2

Tips for Acknowledging a Grievance

- Literacy levels should be taken into consideration when providing the complainant with the acknowledgment of receipt, and verbal acknowledgement should accompany a written acknowledgement.
- Where appropriate acknowledgement should be provided through the Grievance Manager.

1.7.3

Step 3: Assess and Investigate Grievance

The following steps shall be performed in a timely manner to avoid delaying resolution of a grievance:

1. Obtain as much information as possible from the person who received the complaint, as well as from the complainant to gain a first-hand understanding of the grievance.
2. Undertake a site visit, if required, to clarify the parties and issues involved. Gather the views of other stakeholders including ZRA employees, if necessary and identify initial options for settlement that parties have considered.
3. Determine whether the grievance is eligible.
 - Eligible grievances include all those that are directly or indirectly related to ZRA's BGHES Project and that fall within the scope of the Grievance Redress Mechanism as outlined above.
 - Ineligible Complaints may include those that are clearly not related to ZRA BGHES Project or its contractors' activities, whose issues fall outside the scope of the Grievance Redress Mechanism

procedure or where other ZRA or community procedures would be more appropriate to address the grievance.

4. If the grievance is deemed ineligible it can be rejected however a full explanation as to the reasons for this must be given to the complainant and recorded in the Grievance Database.
5. If the grievance is eligible, determine its severity level using the significance criteria in *Box 1.3*. This will help to determine whether the grievance can be resolved immediately or requires further investigation and whether senior management will need to be informed of the grievance.
6. If the grievance concerns physical damage, (e.g. crop, house, community asset) take a photograph of the damage and record the exact location as accurately as possible.
7. Inform the complainant of the expected timeframe for resolution of the grievance.
8. Enter the findings of the investigation in the Grievance Database.

ZRA will aim to resolve any grievances within 30 days from the date that it was received. This timeframe can be extended to 60 days for more complex grievances (e.g. level 4 grievances), if required. (Please see point 6 on assessing grievance significance).

Box 1.3 **Significance Rating Criteria**

Significance Level	Type of Grievance	Responsibilities
Level 1	A grievance that is isolated or 'one-off' and essentially local in nature and restricted to one complainant. Note: Some one-off grievances may be significant enough to be assessed as a Level 4 grievance e.g. when a national or international law is broken (see Level 4 below)	Grievance Manager
Level 2	A grievance that extends to the local community or region and has occurred more than once, which is judged to have the potential to cause disruption to ZRA operations or to generate negative comment from local media or other local stakeholders	Project Executive
Level 3	A grievance which is widespread and repeated or has resulted in long term damage and/or has led to negative comment from local media, or is judged to have the potential to generate negative media and local stakeholder comments (e.g. damage to a sacred site or flooding of local school)	Project Executive
Level 4	A one-off complaint, or one which is widespread or repeated and , in addition , has resulted in a serious breach of ZRA policies, Zambian or Zimbabwean or International Law and/or has led to negative national/international media attention, or is judged to have the potential to generate negative comment from the media or other key stakeholders (e.g. failure to pay compensation where appropriate, e.g. resettlement)	ZRA Chief Executive

1.7.4 **Step 4: Grievance Resolution**

All grievances shall be dealt with on a case by case basis. However, all will require further discussions with complainants and community members that seek to jointly identify and select measures for grievance settlement. This will

help to increase ownership of solutions and to mitigate perceptions that resolutions unfairly benefit ZRA.

- An incident investigation team may be tasked with seeking resolution to the grievance. This may entail a dialog or series of dialogs between affected parties to find a solution to the grievance. Alternatively, it may entail investigating the underlying cause of the grievance and action any changes required to internal systems to prevent a recurrence of a similar grievance.
- An Incident Investigation Report will be completed within 28 days (considered good practice).
- During the 28 days of dialog or investigation, the Grievance Manager will co-ordinate conflict resolution activities necessary to contain and resolve any actual or potential conflicts arising from the reported grievance, refer to *Box 1.2* for tips for resolving grievances. If the case is complex and the stated resolution timeframe cannot be met, an interim response will be provided (oral or written) that informs the stakeholder of the delay, explains the reasons, and offers a revised date for next steps.

Where possible, grievances will be addressed directly by ZRA. The resolution proposal shall be respectful and considered, including rationale for the decision and any data used in reaching it. If wider consultation is necessary, grievances will be forwarded to a third party. This third party should be neutral, well-respected, and agreed upon by both ZRA and the affected parties. These may include public defenders, legal advisors, local or international NGOs, or technical experts. In cases where further arbitration is necessary, appropriate government involvement will be requested.

As a last resort, aggrieved parties have a right to take legal action. This is a more formal rights based approach that shall only be taken if all other approaches have failed or when there are serious conflicts about facts and data. The final decision will be taken by the arbitrator or courts based on compliance with laws, policies, standards, rules, regulations, procedures, past agreements or common practice.

- Grievance verification is especially important when the grievance is about another stakeholder or group of stakeholders. For example the community may make claims against a contractor that need to be investigated before acted upon.
- A regular forum to discuss grievances could be in the form of a monthly meeting where general and Risk Level 1 grievances are discussed. This forum can be constituted more frequently or as is needed especially in the case of Risk Level 2 and 3 grievances. This is particularly relevant to phases of the project that are likely to result in the highest degree of impact (e.g., construction).
- It is important to be transparent about the mechanism to resolve the issue. The appropriate level of action may require further consultation. Also, the issue may be symptomatic of a bigger issue. When this arises, both the symptom and the cause need to be addressed and resolved. For example, a complaint about job seekers setting up informal housing near the site may be raised as an issue related to informal housing but may also be symptomatic of an issue around influx of people and associated negative impacts.
- There are instances where grievances cannot be resolved in 28 days. In these cases, monthly updates must be given to the stakeholders who raised the grievance to provide them a report on progress.

1.7.5***Step 5: Sign-off on Grievance***

- The Grievance Manager will seek sign-off from the complainant(s) that the grievance has been resolved.
- In instances where the stakeholder is not satisfied with actions taken, the grievance will either:
 1. Be escalated to senior management and a decision will be taken either to implement supplementary actions or to consider initiating an appeal process;
OR
 2. The Grievance Manager will approach a neutral or third party to assist in mediating and resolving the grievance;
OR
 3. The Grievance Manager will approach the host country's judiciary to further address the grievance.
- Following this process, the Grievance Manager will again approach the stakeholder to obtain sign-off on actions implemented.
- The staff member who signs off the complaint should have sufficient knowledge about the topic to provide assurance.
- Once sign-off has occurred, this should be recorded in the Grievance Log.

1.7.6***Step 6: Monitoring and Reporting***

ZRA management will monitor grievances routinely as part of the broader management of the Project. This entails good record keeping of complaints raised throughout the life of the construction and operation of the Project. On receipt of grievances, electronic notification to management must be

distributed. Grievance records must be made available to management at all times.

Monthly internal reports will be compiled by the Grievance Manager and distributed to the management team. These grievance reports will include:

- The number of grievances logged in the proceeding period by level and type.
- The number of stakeholders that have come back after 30 days stating they are not satisfied with the resolution.
- The number of grievances unresolved after 60 days by level and type.
- The number of grievances resolved between ZRA and complainant, without accessing legal or third party mediators, by level and type.
- The number of grievances of the same or similar issue.
- ZRAs' responses to the concerns raised by the various stakeholders.
- The measures taken to incorporate these responses into project design and implementation.

These reports and other records will be made available for external review if required.

An appropriate grievance report should be part of ZRA's annual reporting. Annual reports will be made available to the public. A hard copy will be located at the ZRA offices, and an electronic copy will be made available online.

Appendix A

Stakeholder Grievance Forms

STAKEHOLDER GRIEVANCE LOG

To be completed by ZRA personnel (if grievance being submitted in person) or person submitting complaint

Grievance Record		
Reference No: (for official use)		
Anonymous:	Yes	No
Full Name:		
Contact Information: Please mark how you wish to be contacted (letter, telephone, e-mail).	<input type="checkbox"/> Address/village/traditional authority and ward: _____ _____ _____ _____ <input type="checkbox"/> Telephone: _____ <input type="checkbox"/> E-mail: _____	
Preferred Language for communication		
Description of Incident or Grievance:	What happened? Where did it happen? Who did it happen to? What is the result of the problem?	
Date of Incident/Grievance		
	<input type="checkbox"/> One time incident/grievance (date _____) <input type="checkbox"/> Happened more than once (how many times? ____) <input type="checkbox"/> On-going (currently experiencing problem)	
What would you like to see happen to resolve the problem?		
Additional Comments:		

GRIEVANCE RECORD - TO BE USED AS PART OF THE DATABASE

Grievance Record			
Grievance Number:	Date Submitted:	Target Date for Resolution:	
Name:			
Address and Contact Details			
Grievance Received By:			
Name of Grievance Coordinator:			
Description of Grievance:			
Assessment of Grievance Level:		Notification to CEO or other senior management?	Y/N
Actions to Resolve Grievance			
Delegation to:			
Action	Who	When	Completed Y/N/Date
Response/Resolution:			
Strategy to Communicate Response:			
Sign-Off:			
Date:			
Conclusion			
Is complainant satisfied?	Y/N	Comments from Grievance Coordinator	
Grievance Closed?	Y/N	Grievance Resubmitted?	Y/N
Signature of CEO:		Date:	
Date:		New Grievance Number:	

**GRIEVANCE RECEIPT FORM – TO BE USED TO ACKNOWLEDGE GRIEVANCES
SUBMITTED**

Grievance Receipt Form		
Grievance Number:	Date Submitted:	Target date for initial meeting to address grievance:
Name:		
Address and Contact Details		
Grievance Received By:		
Name of Grievance Coordinator:		
Contact details of Grievance Coordinator	Telephone:	
	Email:	
	Address:	

Annex B

Grievance Tracker

Annex B

Method Statement Guidance

METHOD STATEMENT

CONTRACT: **DATE:** _____

PROPOSED ACTIVITY (give title of method statement and reference number from the ESMP):

WHAT WORK IS TO BE UNDERTAKEN (give a brief description of the works):

WHERE ARE THE WORKS TO BE UNDERTAKEN (where possible, provide an annotated plan and a full description of the extent of the works):

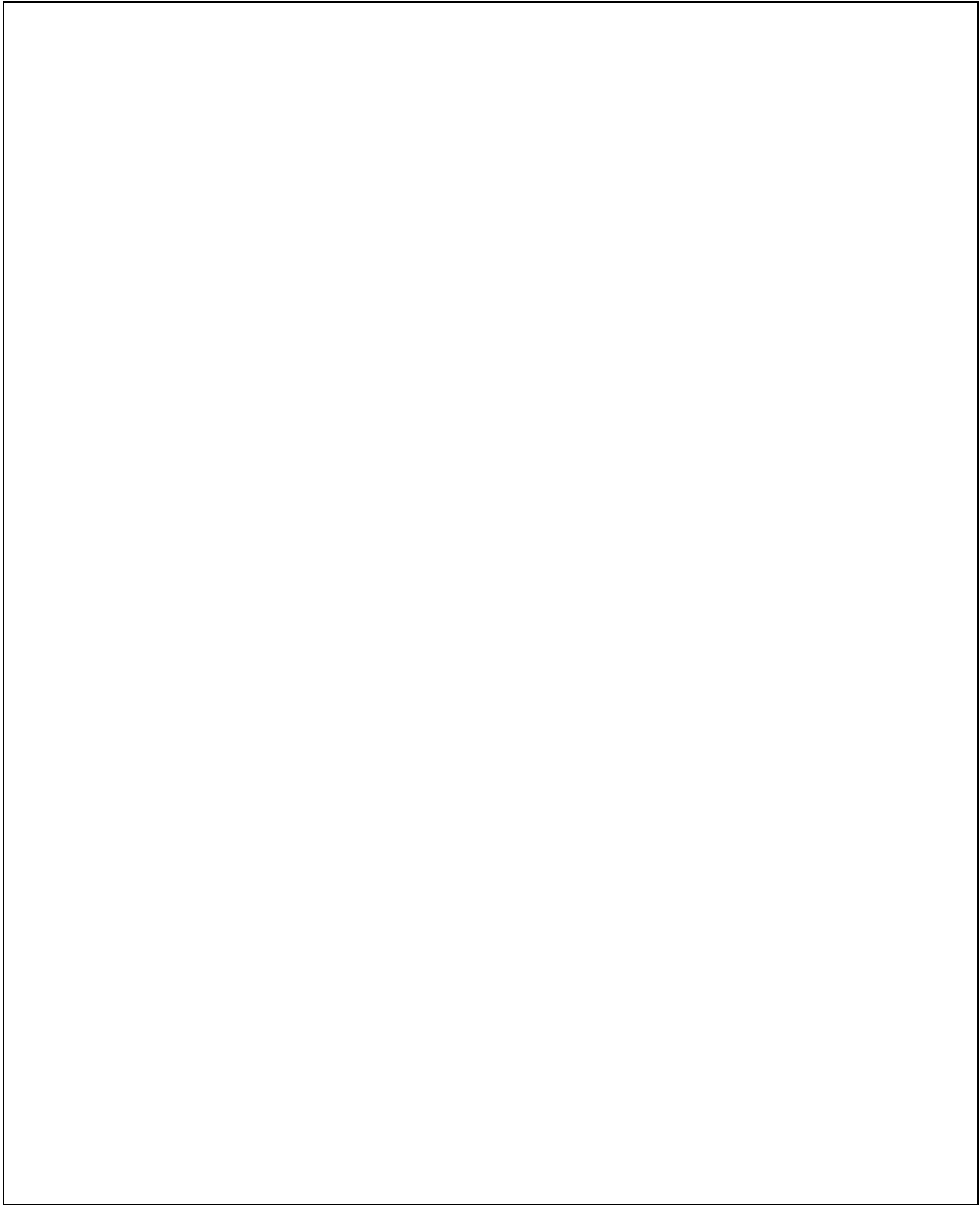

START AND END DATE OF THE WORKS FOR WHICH THE METHOD STATEMENT IS REQUIRED:

Start Date:

End Date:

HOW ARE THE WORKS TO BE UNDERTAKEN (provide as much detail as possible, including annotated maps and plans where possible):



Note: please give too much information rather than too little. Please ensure that issues such as emergency procedures, hydrocarbon management, wastewater management, access, individual responsibilities, materials, plant used, maintenance of plant, protection of natural features etc are covered where relevant

DECLARATIONS

1) RESPONSIBLE OFFICER

The work described in this Method Statement, if carried out according to the methodology described, is satisfactorily mitigated to prevent avoidable environmental harm:

(signed) (print name)

Dated: _____

2) PERSON UNDERTAKING THE WORKS (Contractor)

I understand the contents of this Method Statement and the scope of the works required of me. I further understand that this Method Statement may be amended on application to other signatories and that the SHEQ Manager will audit my compliance with the contents of this Method Statement. I understand that this method statement does not absolve me from any of my obligations or responsibilities in terms of the Contract.

(signed) (print name)

Dated: _____

3) EMPLOYER (*i.e.* Developer/ Owner/Project manager)

The works described in this Method Statement are approved.

(signed) (print name) (designation)

Dated: _____

Annex C

Dam Safety Plan for the BGHES



Zambezi River Authority

BATOKA GORGE HYDRO-ELECTRIC SCHEME



Phase III - FEASIBILITY Vol.7 DAM SAFETY PLAN

September 2019

LIST OF VOLUMES**Vol.1 – 300 GEN R SP 002 – MAIN REPORT****Vol.2 – 300 GEN D SP 001 – FEASIBILITY DESIGN DRAWINGS****Vol.3 – 230 GEN R SP 001 – LIDAR TOPOGRAPHIC SURVEY REPORT****Vol.4 – 310 HYD R SP 001 – HYDROLOGY AND CLIMATE CHANGE REPORT****Vol.5 – 320 GEN R SP 001 – GEOTECHNICAL BASELINE REPORT****Vol.6 – 320 SEI R SP 001 – SEISMIC HAZARD ASSESSMENT REPORT****Vol.7 – 346 GEN R SP 001 – DAM SAFETY PLAN****Vol.8 – 350 STA R SP 001 – DAM STRUCTURAL ANALYSIS REPORT****Vol.9 – 355 GEN R SP 001 A, SPILLWAY NUMERICAL MODEL 1ST and 2ND RUN****Vol.10 – 375 GEN R SP 001 – RESERVOIR OPERATION AND ENERGY PRODUCTION STUDIES****Vol.11 – 380 GEN R SP 001 – ACCESS ROADS AND CAMPS****Vol.12 – 390 GEN R SP 001 – TRANSMISSION SYSTEM DESIGN REPORT****Vol.13 – 390 GEN R SP 002 – POWER EVACUATION STUDIES REPORT**

CONTENTS

GENERAL INTRODUCTION.....	8
1.1 CONTENT AND STRUCTURE OF THE DAM SAFETY PLAN.....	8
1.2 GLOSSARY AND ABBREVIATIONS	Errore. Il segnalibro non è definito.
PART A - CONSTRUCTION SUPERVISION and QUALITY CONTROL PLAN	10
A.1 INTRODUCTION.....	11
A.1.1 CONTENT AND STRUCTURE OF THIS PART.....	11
A.2 METHODOLOGY	12
A.2.1 INTRODUCTION	12
A.2.2 CONSTRUCTION SUPERVISION and QUALITY CONTROL PLAN ACTIVITIES	12
A.2.3 LEVEL 1 DESIGN REVIEW	14
A.2.4 CONTRACTOR'S COORDINATION ACTIVITIES	16
A.2.5 LEVEL 2 CONSTRUCTION DESIGN REVIEW	16
A.2.5.1 Hydro and Electro-mechanical equipment	17
A.2.5.2 Civil Works and Ancillary Installations	18
A.2.5.3 Modification to Design.....	19
A.2.5.4 Structural Analysis	19
A.2.6 RESPONSIBILITY of CONSULTANT's TEAM	20
A.2.7 QUALITY ASSURANCE and SCHEDULE of EXECUTED WORKS.....	20
A.2.8 REVIEW of TOPOGRAPHY and SURVEYING	21
A.2.9 SITE SUPERVISION	22
A.2.9.1 Testing	23
A.2.9.2 Quality Control of civil works.....	24
A.2.9.3 Quality Control of Hydro-Mechanical and Electrical equipment	28
A.2.9.4 Geological Inspection	32
A.2.9.5 Monitoring, Instrumentation System and Emergency Preparedness Plan	34
A.2.9.6 Monitoring of Construction schedule	35
A.2.9.7 Commissioning programme.....	37
A.2.9.8 Reservoir Impounding	38
A.2.9.9 Testing and Final Control of Equipment.....	40
A.2.10 SERVICES DURING DEFECT LIABILITY PERIOD	41
A.2.11 HANDLING of CLAIMS	42
A.2.12 MANAGEMENTS of PAYMENTS	43

A.2.13	TRANSFER of KNOWLEDGE.....	44
A.2.13.1	Approach and Methodology	45
A.2.13.2	On-the-Job Training to Owner’s Personnel	45
A.2.13.3	Workshops and Presentations Carried out by Consultant Experts.....	46
A.2.13.4	Technical Presentation at the Different Milestones of the Project.....	46
PART B - INSTRUMENTATION PLAN		47
B.1 INTRODUCTION.....		48
B.1.1	CONTENT AND STRUCTURE OF THIS PART.....	48
B.2 DAM INSTRUMENTATION OPERATION AND MONITORING		49
B.2.1	INTRODUCTION	49
B.2.2	INSTRUMENTS CONTROL PLAN SUMMARY TABLE	49
B.2.3	INSTRUMENTS MEASUREMENTS REPORTING.....	54
B.2.4	METEO and RIVER LEVELS MEASUREMENTS	55
B.2.5	RESERVOIR WATER LEVEL MEASUREMENTS	56
B.2.6	OUTFLOWS AT POWER HOUSES	56
B.2.7	WATERS MONITORING: SPRINGS	57
B.2.8	WATERS MONITORING: DAM PIEZOMETERS.....	57
B.2.9	DAM DRAIN MONITORING.....	58
B.2.10	THERMOCOUPLES.....	60
B.2.11	FIBER OPTIC CABLES	61
B.2.12	EXTERNAL BENCHMARKS	61
B.2.13	COLLIMATORS WITH FIXED AND MOBILE AIM	61
B.2.14	JOINT DEFORMOMETERS	62
B.2.15	PENDULA	62
B.2.16	EXTENSOMETERS	62
B.2.17	ACCELEROGRAPHS	63
B.2.18	DOWNSTREAM WORKS INSPECTION.....	63
B.3 DAM MONITORING RESULTS ELABORATION: ROUTINE AND ALERT CONDITIONS..		64
B.3.1	INTRODUCTION	64
B.3.2	CRITERIA FOR ROUTINE OR ALERT PROCEDURE APPLICATION	65
B.3.3	UPLIFT PRESSURES ON DAM FOUNDATIONS	67
B.3.4	GROUNDWATER CIRCULATION.....	69
B.3.5	LEAKAGES.....	71
B.3.6	FOUNDATION SETTLEMENTS and DAM DISPLACEMENTS.....	72
B.3.7	DAM THERMAL CONDITIONS.....	73

B.3.8	ROUTINE PROCEDURE	73
B.3.9	ALERT PROCEDURE	73
B.3.10	CONTROLLED DRAWDOWN PROCEDURE	73
B.3.11	EMERGENCY DRAWDOWN PROCEDURE.....	74
PART C - OPERATIONAL PLAN (Preliminary Plan)		75
C.1	INTRODUCTION.....	76
C.1.1	CONTENT AND STRUCTURE OF THIS PART.....	76
C.2	ROLES and RESPONSIBILITY.....	78
C.2.1	LEGISLATIVE FRAMEWORK.....	78
C.2.2	MANAGEMENT STRUCTURE	79
C.2.3	SITE STAFF SKILLS AND TRAINING.....	79
C.3	SYNTHESIS OF RESERVOIR AND PLANT OPERATING CONDITIONS.....	80
C.3.1	GENERAL	80
C.3.2	PLANT OPERATING CONDITIONS AND FACILITIES DESCRIPTION	80
C.3.3	NORMAL OPERATIONS DESCRIPTION	82
C.3.4	EXCEPTIONAL OPERATIONS DESCRIPTION.....	83
C.3.5	POWER SUPPLY FOR BATOKA PLANT OPERATION.....	83
C.4	PLANT HYDRAULIC CONTROL DEVICES OPERATION.....	85
C.4.1	GENERAL	85
C.4.2	INSTRUCTIONS FOR ECOLOGICAL FLOW RELEASE.....	85
C.4.3	MIDDLE OUTLET UPSTREAM GATE OPERATION	86
C.4.4	MIDDLE OUTLETS DOWNSTREAM GATES OPERATION.....	87
C.4.5	RESERVOIR DRAWDOWN	88
C.4.6	SPILLWAY GATES OPERATION.....	89
C.4.7	SPILLWAY STOPLOGS OPERATION.....	89
C.4.8	INTAKE BULKHEAD GATES OPERATION.....	90
C.4.9	INTAKE WHEEL GATES OPERATION	91
C.4.10	POWER WATERWAYS EMPTYING AND FILLING OPERATION	92
C.4.11	ACCESS TO EMPTY POWER WATERWAYS FOR INSPECTION & MAINTENANCE PURPOSES	92
C.4.12	MAIN INLET VALVES OPERATION.....	93
C.4.13	DRAFT TUBE GATES OPERATION	95
C.4.14	DRAFT TUBE STOPLOGS OPERATION	95
C.5	OTHER PRESCRIPTIONS FOR CIVIL WORKS OPERATION	97
C.5.1	GENERAL	97

C.5.2	RESTRICTED AREAS.....	97
C.5.3	LOADS AND ACCESS LIMITATIONS	98
C.5.4	TRANSFORMER OIL WATER RECOLLECTION SYSTEM OPERATION.....	99
C.5.5	PLUNGE POOL AND TAILRACE CLEANING	100
C.5.6	USE of RESERVOIR FLOATING BARRIER	100
C.5.7	ACCESS TO DAM AND RELEVANT GALLERIES.....	101
C.6	ORGANIZATION, TRAINING AND FACILITIES FOR PLANT OPERATION	102
C.6.1	ORGANIZATION OF THE PLANT MANAGEMENT STRUCTURE	102
C.6.2	OPERATORS TRAINING	102
C.6.3	EQUIPMENT AND FACILITY REQUIREMENTS FOR BATOKA PLANT	103
C.6.4	FORMAT FOR SPARE PARTS LIST	103
C.6.5	CONTACTS FOR ROUTINE OR ALERT PROCEDURE IMPLEMENTATION	104
C.6.6	CONTACTS FOR EMERGENCY or ALARM CASES	104
PART D	- MAINTENANCE PLAN (Preliminary Plan).....	106
D.1	INTRODUCTION.....	107
D.1.1	CONTENT AND STRUCTURE OF THIS PART.....	107
D.2	PROCESS OF INSPECTION AND MAINTENANCE	108
D.2.1	GENERAL APPROACH	108
D.2.2	ROLES AND RESPONSIBILITY	110
D.2.3	PROCEDURE FOR CIVIL WORKS INSPECTIONS AND MONITORING	110
D.2.4	GUIDELINES FOR MAINTENANCE ACTIVITIES.....	113
D.2.5	FIVE-YEARLY DAM SAFETY VERIFICATION.....	114
D.3	MAINTENANCE.....	115
D.3.1	RESERVOIR MAINTENANCE	115
D.3.2	DAM CIVIL WORKS MAINTENANCE	117
D.3.3	MIDDLE OUTLETS MAINTENANCE.....	121
D.3.4	SPELLWAY MAINTENANCE	123
D.3.5	PLUNGE POOL MAINTENANCE	125
D.3.6	INTAKE GATES STRUCTURE and relevant upper yard MAINTENANCE.....	127
D.3.7	POWER TUNNEL MAINTENANCE	128
D.3.8	SURGE SHAFT MAINTENANCE.....	130
D.3.9	PENSTOCKS MAINTENANCE.....	131
D.3.10	POWER HOUSE MAINTENANCE.....	132
D.3.11	SWITCHYARD MAINTENANCE.....	136
D.3.12	ACCESS ROADS MAINTENANCE.....	138

D.3.13	PERMANENT CAMP	139
D.3.14	HYDRAULIC DEVICES AND MAIN CONTROL EQUIPMENT MAINTENANCE.....	140
D.4	TYPICAL FORMAT FOR INSPECTION CHECK SHEET	147
PART E	- EMERGENCY PREPAREDNESS PLAN (Framework Plan)	148
E.1	INTRODUCTION.....	149
E.1.1	CONTENT AND STRUCTURE OF THIS PART.....	149
E.2	STRUCTURE AND REVIEW OF THE PLAN.....	151
E.2.1	GENERAL	151
E.2.2	PRINCIPLES.....	152
E.3	EMERGENCY CASES.....	153
E.3.1	TYPE OF EMERGENCIES and RESPONSE LEVEL MATRIX.....	153
E.3.2	TYPE OF EMERGENCIES	155
E.4	INITIATION OF THE EMERGENCY ACTION PLANS.....	156
E.4.1	HAZARD CONTEXT	156
E.3.1	EMERGENCY IDENTIFICATION AND EVALUATION	156
E.5	EMERGENCY RESPONSE AND ACTION PLANS	158
E.5.1	INITIAL RESPONSE AND EMERGENCY INSPECTIONS	158
E.3.2	EMERGENCY INSPECTIONS CHECKLISTS	158
E.5.2	EMERGENCY ACTION PLANS.....	168
E.6	PREPAREDNESS PLAN IMPLEMENTATION	175
E.6.1	ACCESS ROUTES – PRIMARY AND SECONDARY.....	175
E.6.2	PUBLIC SAFETY	176
E.6.3	SITE SECURITY	176
E.6.4	ON SITE RESOURCES.....	177
E.6.5	CONTROLLED DRAWDOWN PROCEDURE	178
E.6.6	EMERGENCY DRAWDOWN PROCEDURE.....	178
E.6.7	INFORMATION TO THE PEOPLE LIVING IN THE RESERVOIR AREA	179
E.7	CONTINGENCY PLAN	180
E.7.1	INTRODUCTION	180
E.7.2	IMPENDING FAILURE OR FAILURE	180
E.7.3	LARGE OR SUDDEN RELEASE DOWNSTREAM OF THE DAM	181

E.7.4	CONTACTS FOR EMERGENCY or ALARM CASES	182
E.8	DAM BREAK ANALYSIS	183
E.8.1	INTRODUCTION	183
E.8.2	TOPOGRAPHIC DATA	184
E.8.3	VALLEY MORPHOLOGY AND HYDRAULIC CHARACTERISTICS OF STREAMFLOW.....	184
E.8.4	FLOOD ROUTING MODEL - HEC RAS version 5.05 (2D)	185
E.8.5	MODEL GEOMETRY – COMPUTATION MESH.....	186
E.8.6	LAND COVER and MANNING’S COEFFICIENTS.....	188
E.8.7	BREACH HYDROGRAPH PREDICTION AND BOUNDARY CONDITIONS	188
E.8.8	RESULTS.....	190

Annex A Drawings

346 DBK D SP 001	Inundation area, General, 300k
346 DBK D SP 002	Inundation area, Key map, 300k
346 DBK D SP 003	Inundation area, plan 100k , sheet 1 of 4
346 DBK D SP 004	Inundation area, plan 100k , sheet 2 of 4
346 DBK D SP 005	Inundation area, plan 100k , sheet 3 of 4
346 DBK D SP 006	Inundation area, plan 100k , sheet 4 of 4

<i>GLOSSARY & ABBREVIATIONS</i>

CDP	Controlled Drawdown Procedure
EAP	Emergency Action Plan
EDP	Emergency Drawdown Procedure
EM eq	Electro-mechanical equipment
EPP	Emergency Preparedness Plan
GS	Gate Shaft
HPP	Hydro Power Plant
HSS eq	Hydraulic Steel Structure equipment
IL	Invert level
MLO (or MO)	Middle Level Outlet (or Middle Outlet)
OHL	Over Head Line (electric transmission high voltage line)
PMS	Plant Management Structure
PH	Power House
PP	Plunge Pool
PT	Power Tunnel
RCC	Rolled Compacted Concrete
SS	Surge Shaft
SWY	Switchyard
SP	Studio Ing. G. Pietrangeli - Rome
ZRA	Zambezi River Authority

GENERAL INTRODUCTION

1.1 CONTENT AND STRUCTURE OF THE DAM SAFETY PLAN

The Dam Safety Plan is articulated in the following parts:

A. CONSTRUCTION SUPERVISION AND QUALITY CONTROL PLAN

This part contains the organization, procedures and activities required for supervision of the construction of the Batoka Plant.

B. INSTRUMENTATION PLAN

It describes the monitoring system of Batoka Dam, and it contains the instruction for measurements to be collected by the instruments, for their presentation, use and assessment.

C. OPERATIONAL PLAN (Preliminary Plan)

It provides the guidelines for the operation of the Batoka scheme, including the dam, power waterways, power house and other appurtenant structures.

D. MAINTENANCE PLAN (Preliminary Plan)

It outlines the operation and maintenance activities and procedures relevant to the Batoka Dam and Hydro Power Plants.

E. EMERGENCY PREPAREDNESS PLAN (FRAMEWORK PLAN)

It contains the Batoka Emergency Preparedness Plan that includes the description of types of emergencies and how to identify them, the actions to take in case of emergency and the preparedness and Emergency Response. Moreover, the dam break analysis is included in this part.

The Dam Safety Plan is prepared according to the World Bank Dam Safety safeguard policy (ESS4 e.g. Environmental and Social Standard 4 -Community Health and Safety).

This revision B has been updated in order to add the results of the dam break analysis in part. E.

Each part is self-standing. The dam safety plan is provided on the basis of the knowledge of the project at this feasibility design stage and shall therefore be integrated and detailed with the development of the project, to become an operative tool for the operation of the dam and of the plants.

It is assumed that:

- The Dam Safety Plan, and in particular the operation and maintenance of the Dam and of the two Power Plants, will be assigned by the Plant Owners to their departments or entities or internal/external consultants dedicated to the control, operation and maintenance of dam and national power plants, that in this report will be always referred as "Plant Management Structure" (PMS).
- The project at this stage is considered as a whole, and this document is conceived as a base from which it will be possible:

- To split it in lots, and to identify possible limits and definition of responsibility among the actors involved in the owning and management of the dam and plants.
- to develop in detail the Dam Safety Plan, progressively with the subsequent developments of the project, to become an operative tool for the operation of the dam and of the plants.
- This report is based on the Feasibility Design of Batoka Project, to which reference is made. This report is deemed therefore integrated by the Feasibility Design reports and drawings.

It is assumed in particular that this plan will be integrated progressively with:

- detailed design drawings and reports
- then the as-built drawings
- original equipment or materials (as far as applicable) manufacturers' operations and maintenance recommendations and manuals,
- EM and HSS Equipment Operation and Maintenance Manuals.
- This plan must be reviewed and updated as necessary:
 - To reflect the conditions of the detailed design and then of the construction on site whenever they will result substantially different from what assumed in this report.
 - Whenever any significant change to the scheme occurs, including any changes to the operating rules.
 - At intervals of 5 years after Plant commissioning.
 - Following any ownership change.

**PART A - CONSTRUCTION SUPERVISION and
QUALITY CONTROL PLAN**

A.1 INTRODUCTION

A.1.1 CONTENT AND STRUCTURE OF THIS PART

This is the **PART A "CONSTRUCTION SUPERVISION and QUALITY CONTROL PLAN"** of the Batoka Dam Safety Plan.

This part contains the organization, procedures and activities required for supervision of the construction of the Batoka Plant.

Some of the guidelines provided in this section shall be detailed when the relevant construction contract(s) is put in place.

A.2 METHODOLOGY

A.2.1 INTRODUCTION

This chapter provides the description of the organization, staffing levels, procedures, equipment, and qualifications for supervision of the construction of Batoka dam.

It is developed at feasibility design stage, being assumed to be fine-tuned at the moment of these tasks assignment.

It is focused on the activities to be carried out for the Design Review, Construction Management, Supervision, Testing and Commissioning of Batoka Project.

It is conceived assuming that the works will be executed by the relevant Contractor(s) through EPC procurement method, therefore the duties of supervision will be in compliance with the requirements of the international practice foreseen in the "SILVER Book", prepared by the International Federation of Consulting Engineers (FIDIC) for this type of Contract.

Any adjustments in respect to the above assumptions are still possible in the further steps of design and construction phases, when also the structure that the Owner will put in place for the supervision (that for simplicity will be called hereinafter "Supervisor", that can be within his internal resources or recurring to external consultancy) will be defined.

A.2.2 CONSTRUCTION SUPERVISION AND QUALITY CONTROL PLAN ACTIVITIES

The Construction Supervision and quality control include the classical activities for the supervision of construction such as:

- **DESIGN REVIEW**
Review and approval of the Contractor's design following the design implementation schedule in order to ensure technical soundness and compliance with the Client's requirements, prior to commencement of the Works.
Design's review includes Feasibility Design appraisal, Draft Final and Final Design prepared by the Contractor for all Civil Works, Electro-mechanical equipment and Hydraulic Steel structures.
- **REVIEW of TECHNICAL SPECIFICATIONS and BILL of QUANTITIES**
Review and approval of Technical Specifications and Bill of Quantities for all Civil Works, Electro-mechanical equipment and Hydraulic Steel structures to ensure that they fully comply with the Client's Requirements being economically sound.
- **REVIEW of WORK PROGRAMME**
Review of Contractor's Work programme in order to verify its compliance with the Implementation Plan and to verify progress of the Works, actual and planned rate of production and highlight any criticality and/or delay emerged during the implementation of Design / Works.

- **REVIEW of METHOD STATEMENTS**
Review of Contractor’s Method Statements for all Civil Works, Electromechanical Works, Electrical Works and Hydraulic Steel Works, in order to ensure technical soundness of the proposed solutions.
- **REVIEW of MANAGEMENT PLANS**
Review of the Management Plans of all the elements / personnel / equipment involved in the production chain of the Works to ensure timely production and quality of the Works.
- **SUPERVISION during CONSTRUCTION, ERECTION TESTING and COMMISSIONING**
Supervision of construction, erection, testing and commissioning of all project Works to ensure their compliance with the approved Designs, Drawings, Specifications, Conditions of Contract, Work Programme and state-of-the-art Engineering Practice.
During this phase of the assignment, it will be carried out a supervision and control of all environmental activities, including but not limited to those related to quarry exploitation, dumping of materials, impounding process and demobilization stages.
- **MANAGEMENT of INVOICES and PAYMENTS**
Verification of all payment invoices issued by the Contractor and preparation of acceptance certificates for the Works completed.
- **ADMINISTRATION of CLAIMS** arising from the Contractor.
- **POST-CONSTRUCTION SERVICES** during defects liability period.
Verification that the performances of all the elements of the project comply with the Contract, Technical Specifications and Client’s Requirements.

The activities listed above, and detailed in the following paragraphs, shall be carried out throughout the entire Contract period, including Defect Liability Period, under and in close cooperation with the staff of the Client. The activities shall be carried out in order to guarantee a smooth implementation of the works in accordance with the EPC contract, Client’s Requirements and state-of-the art technology. For this purpose, periodical and also specific Design / Managerial Coordination meetings are to be organized.

For sake of completeness, the minimum qualifications and experience of personnel responsible for the Level 1 and Level 2 design and review process are illustrated in the following table.

No.	<i>Position</i>	<i>General Qualifications and Specific Experience</i>	<i>Total experience (min. years required)</i>	<i>In similar works (min. years required)</i>	<i>As manager/specialist of similar works (min. years required)</i>
1.	Project Manager	Bachelor’s degree in Engineer with international experience in design, planning and construction of hydropower plant (at least rated 100 MW), contract budgeting and staff coordination capabilities. Familiar with FIDIC Contract	20	15	5
		Designer Team Mambers			
2.	Hydropower Engineer/Responsible Design	Bachelor’s degree in Engineer experienced in preparation of detailed design for hydropower plants of more than 100 MW	20	10	5

		adequate experience as a Team Leader and Responsible Designer			
3	Dam Engineer	Bachelor's degree in Engineer with international experienced in preparation of detailed dam according to ICOLD criteria.	15	10	5
4.	Geology/Geotechnics specialist	Bachelor's degree in Geology Engineer with experienced in engineering geology, research interpretation as a responsible design engineer in geology/geotechnical designs for hydropower plants	15	7	5
5.	Hydraulic specialist	Bachelor's degree in civil Engineer with experience as a responsible design engineer in hydro-structure of a facility and experienced in hydraulic modelling of hydropower plants of more than 100 MW and dam according to ICOLD criteria	15	7	5
6.	Structural and Construction specialist	Bachelor's degree in civil Engineer with experience as a responsible design engineer in designing structures of hydro-construction facilities of more than 15 MW and dams according to ICOLD criteria	15	7	5
8.	Roads specialist	Bachelor's degree in Civil Engineer with experience in designing of different categories of roads	10	7	5
10.	Mechanical equipment specialist	Bachelor's degree in Mechanical Engineer with experience as a responsible design engineer of detailed designs of mechanical equipment in hydropower plants of more than 100 MW	15	7	5
11.	Hydromechanical equipment specialist	Bachelor's degree in Mechanical Engineer or Graduate Civil Engineer with experience as a responsible design engineer of detailed designs for hydromechanical equipment in hydropower plants of more than 100 MW	15	7	5
12.	Electrical equipment specialist	Bachelor's degree in Electrical Engineer experienced as a responsible design engineer of detailed designs for electrical equipment of voltage up to 110kV in HPP	15	7	5
13.	Electrical equipment specialist for control protection and monitoring system	Bachelor's degree in Electrical Engineer with experience in designing as a responsible design engineer of detailed designs for control protection and monitoring system of the hydropower plants	10	7	5
15.	Quality Assurance/Quality Control Manager	Graduated Specialist, experienced in QA/QC activities in hydropower projects	10	10	5
17.	Health & Safety Engineer	Bachelor's degree in a safety or technical engineering field of study, as well as several years of experience managing and working in the field of health and safety in hydropower plants	10	7	5
17.	Environmental and Social expert	Graduated Specialist experienced in implementation and monitoring of environmental and social issues in the civil construction activities	10	7	5

A.2.3 LEVEL 1 DESIGN REVIEW

In compliance with the condition of Contract and Client's Requirements, the Contractor will prepare and submit the Level 1 design of the civil, electrical and mechanical works. It is stressed that in this phase of the Design the Contractor shall start all the investigation activities required to finalize the Design of the Works.

Therefore, before starting construction activities, the Supervisor will review the investigation programme proposed by the Contractor and the Level 1 design, carrying out the following main activities:

- review the design in accordance with the Client Requirements, condition of Contract, state-of-the art engineering international practice;
- review the design in accordance with the actual site requirements and the results of latest investigations available;
- ensure that the most cost effective and technically sound alternatives are examined and appropriate designs are produced accordingly;
- examine thoroughly the technical documentation (bill of quantities, specifications and methods of measurement etc.) in order to point out any discrepancy or mistake which may jeopardise the prompt implementation of the project causing major changes, disputes and claims.

The Supervisor will verify that the Level 1 Design includes all the elements required for a full understanding by the Client or the Clients Representative of the key features proposed, such as:

- general arrangement and emplacement of the project structures;
- general hydraulic design of:
 - diversion structures;
 - main gated spillway;
 - Middle Level Outlets;
 - Ecological Discharge devices;
 - power waterways (including head losses calculations and basic transient analyses);
- design of electrical equipment;
- design of civil works;
- design of the mechanical equipment;
- design of the hydraulic steel structures;
- sizing and general characteristics of the main equipment of each powerhouse;
- drawings of the turbine parts and of the discharge pit and tailrace dimensioned at Level 1 stage;
- calculations verifying the average annual energy production;
- single line diagrams;
- Level 1 arrangement and assembly drawings of the powerhouse complex, showing construction of main components, leading dimensions and masses and confirmed locations;
- Level 1 study of the equipment erection sequence and requirements, to the extent needed to determine space and facilities required in the powerhouse erection areas;
- calculations and studies required to justify and support the proposed technical solutions. They will also include:
 - results of the field and laboratory investigations performed up to that moment and program for any additional investigations deemed necessary;
 - design criteria, standards and design codes proposed for the development of the designs during construction;
 - technical specifications for the civil and building works;
 - technical specifications for the hydraulic steel structures;

-
- technical specifications for the electrical works, including generating equipment and powerhouse electrics;
 - technical specifications for the powerhouse lighting, ventilation, air conditioning, and fire-fighting systems;
 - Quality Assurance Plan and manuals.
 - a detailed program of the phases of design, material supply, manufacture, delivery, erection and commissioning of the equipment;
 - any other technical documents to be submitted according to the Contract.

A "No Objection" will be issued when the submitted documents are correct and complete. "Verified-Comply with Comment" will indicate that the calculations and/or the main arrangements defined by the documents are considered essentially correct, but require minor rectifications so as to complete or clarify certain points having only trivial influence on the design, the behaviour and/or the safety of the structure or of the equipment. On the contrary, should the Supervisor consider the documentation insufficient, or as giving inadequate guarantee on the behaviour and/or the safety of the structure or equipment, the document will be classified as "Rejected, comply with comments, Re-submittal required". Such labelling will be transmitted together with the necessary explanations to correct the document so that the Contractor may re-submit the rectified documents.

A.2.4 CONTRACTOR'S COORDINATION ACTIVITIES

The Contractor will be requested to submit a clear procedure, to be approved by the Supervisor, which specifies the detailed design process of both the civil engineering structures and EM and HSS equipment. The main aim of this procedure is to guarantee that the design of these elements and also the erection process is carried out consistently and with the required coordination:

- reducing the problems of construction interfaces;
- guaranteeing the timely delivery on site of the necessary information for construction (construction drawings, method statements, installation manuals);
- assuring the availability on site of the required equipment, man-power and permanent materials.

The everyday follow-up of these procedures will be the responsibility of the Contractor who will report to the Supervisor.

A.2.5 LEVEL 2 CONSTRUCTION DESIGN REVIEW

The Supervisor will review the construction drawings and reports of the civil works, of the hydro-mechanical, mechanical and electrical equipment.

The review performed at this stage is aimed to verify that the construction and manufacturing design documents correspond to the design solutions and relevant comments formulated during the previous phase. In this regard the Contractor will submit for review the general arrangement drawings and relevant specifications and calculations of all components parts of the Works, i.e. all the documents required by the Contractor to construct, erect, test and commission all the components of the Permanent Works (construction drawings, detailed technical specifications, construction and erection method statements, commissioning and testing procedures, etc.).

The Contractor will prepare a list and a time schedule for preparation for the submission of the Construction and Manufacturing Design documents.

The design activity during construction includes the progressive preparation of "As-built" drawings, which are an essential part of the documentation needed to properly maintain all the works and the equipment in their lifetime and to eventually rehabilitate them.

The Contractor will be required to prepare and keep a complete, up-to-date, set of as-built drawings showing the locations, sizes and details of the works as executed, adopting the format, referencing system and other relevant details previously agreed.

The Supervisor will verify that all modifications of the civil, hydro-mechanical, electro-mechanical and electrical drawings, introduced after the acceptance of the drawing, have been correctly and properly recorded and that the drawings are complete in all parts and comply with the latest accepted version of the technical calculations.

A.2.5.1 Hydro and Electro-mechanical equipment

Before proceeding with the manufacturing of the:

- gates, linings, and other steel structures;
- mechanical, hydro-mechanical and electrical equipment

The Contractor will be required to submit the following documents for review and comment on conformity with design criteria by the Supervisor:

- calculations carried out for determining the plate thicknesses, the welding and other structural characteristics of the penstocks, clearly indicating the principles on which calculations are based;
- general assembly drawings, sufficient sub-assembly drawings and details to demonstrate that all parts will conform to the provisions and intent of the Contract and to the requirements of their installation and maintenance. These drawings will show all necessary dimensions and sub-assemblies in which the Contractor proposes to ship the steel elements. The Contractor will also submit grounding location and details installation drawings;
- other detailed design drawings and documents that the Supervisor may require.

The Contractor will submit all erection drawings, showing the sequence of EM and HSS erection, erection equipment required, field welding works, erection / welding / concrete embedment sequence, etc. for review.

A.2.5.2 Civil Works and Ancillary Installations

The Contractor will develop the detailed design for construction and manufacturing of the civil works and ancillary installations basing on the comments relevant to previous Design phase.

Submissions to the Supervisor for its review and comment related to the Design of civil works typically include:

- Level 2 drawing of the outdoor and underground excavations, together with the required rock support and slopes stabilisation measures, supported by the necessary geotechnical analyses;
- Level 2 drawings and calculations of RCC dam, including stability analysis, thermal analysis, dam zoning, instrumentation system;
- Level 2 concrete outline drawings, showing all dimensions, first and second stage concrete, contraction and construction joints, classes of concrete and finishing, etc.;
- concrete reinforcement drawings, showing bars diameters, and spacing, supported by the necessary structural analyses and by the equipment design data which may be necessary to check the loads and design criteria applied;
- arrangement and details of embedded parts (water stops, piping systems, conduits, embedded parts for equipment erection etc.);
- architectural and miscellaneous finishing drawings;
- Level 2 method statements for all civil construction activities;
- details of the installations (crushing plant, batching plant, cooling system, conveyor system, etc...);
- other Level 2 design drawings and documents that the Supervisor may require.

Notwithstanding any Supervisor review and comment, in the frame of the EPC Contract nature the Contractor will be fully responsible for the correctness of the detailed drawings of the civil works, particularly in relation to the loads, dimensions, embedded parts and any other interface with the equipment.

The Contractor will submit the Level 2 Design of the civil structures in an orderly sequence, following the priorities of the construction program, so that the time allocated for the Supervisor's comment and review and possible request for corrections and/or modifications will not cause delays, and excessive simultaneous submissions are avoided.

Any other drawing, calculation note and design document that the Contractor may deem necessary for his own use, such as reinforcing bars bending schedules, materials lists, etc. will be submitted to the Supervisor for its information.

A.2.5.3 Modification to Design

In case, during the implementation of the Works, the Contractor will propose modifications to the Design due to practical reasons or to account to un-expected local conditions or constrains, the Supervisor will verify and check:

- the need of such modifications,
- their suitability,
- the overall impacts on the Works in terms of time for completion, quality, safety, interferences and/or repercussions with other parts or subsequent phases of the project.

If the Supervisor finds that issuance of a variations would be essential and / or unavoidable (unless an emergency occurs affecting safety of the Works, or any delay with the variation shall give rise to a substantial time overrun) the Supervisor will provide a Level 1 report outlining the evaluation of such variation, including but not limited to the following:

- the Supervisor's opinion on the extent, if any, of the applicability of the varied Works compared to the approved Design;
- conformity to Client's Requirements and international state-of-the-art engineering practice;
- potential interferences and/or repercussions with other parts or phases of the Project;
- potential impacts on Project Implementation Plan.

It will be arranged in the shortest possible time coordination meetings with the parties, in order to examine the proposal for modification and review / incorporate the modification in the detailed Contractor's Work Program. The Supervisor will verify that the approved modification to Design is reflected and incorporated in all relevant Design documents including Construction drawings, Method Statements and Quality plans. The above process will be carried out, as far as possible, in order not to disrupt the Construction Schedule.

In addition, all changes to work activities that move away from the approved designs shall require the Contractor to submit a change request form and the associated revised designs and drawings where applicable to the Supervisor for approval consistent with the Project Change Management Plan.

A.2.5.4 Structural Analysis

The Supervisor will ensure that the Contractor has carried out all the Level 2 calculations by applying the principles, rules, norms, and procedures discussed and verified beforehand by the Supervisor. The Supervisor will verify and approve detailed calculations, drawings and/or supporting reports submitted by the Contractor.

Structural analysis shall include all the main structures including but not limited to: RCC dam, embankments, powerhouse, diversion works, power tunnels, intake structures, shafts, switchyards, bridges and all the ancillary works of the project.

A.2.6 RESPONSIBILITY OF CONSULTANT'S TEAM

Design review, Supervision of manufacturing, testing, erection, commission and Construction Management of all the project elements will be the responsibility the Supervisor.

To achieve these goals the Supervisor will mobilize and maintain on site throughout the entire construction and commissioning period the supervisory team, composed by Resident Engineers, Key Staff and support Staff, as detailed in following paragraphs.

Whenever the Supervisor duty will be assigned by the Owner (intended as final Client of the EPC Contract) to an external international Consultant, typically the Consultant's team will be structured so to be assisted by a Client's Project Team designated by the Client, with the main goal to use the opportunity of the Design Review and Construction Management of Batoka Project to transmit the international experience of the Consultant to Client's Project Team.

The Client's Project Team will assist the Consultant's Team in the field; however, the activity of Client's staff will not relieve the Consultant from any obligation and/or responsibility foreseen in his contract for services.

The project's team may need to be equipped with the knowledge of FIDIC.

Typical structure and methodology for such Knowledge Transfer are given in relevant paragraphs.

A.2.7 QUALITY ASSURANCE AND SCHEDULE OF EXECUTED WORKS

The Contractor will be required to guarantee the continuous control over the quality of the Works and its schedule through a Quality Assurance Plan (QAP). This QAP should define, in particular:

- organization of Contractor's Quality System;
- Quality Plan for Design;
- materials that he proposes to incorporate into the construction;
- methods planned to carry out every part of the works, and the resources needed;
- programme of the tests and controls (with relevant records) he intends to follow to prove that the requested quality is obtained;
- schedule of works and control of deviations and relevant countermeasures;
- management of non-conformities.

The Contractor under the EPC Contract will be required to be fully responsible of the quality of the proposed design and construction. The primary duty of the Supervision regarding quality are to make sure that the Contractor's Quality Plan is working properly.

The Supervisor will therefore review the Quality Assurance Plan, perform inspections in the workshops and laboratories and work areas to assess the application and conformity to the Quality Assurance Plan.

For each Work phase the Supervisor's staff, while verifying that the relevant Construction documentations are made available and that construction equipment is mobilized by the Contractor in accordance with the Work programme, shall pay particular attention while checking the following aspects:

- Organization and conditions of the Laboratory, including the competence of the Laboratory Staff.
- Method Statements proposed by the Contractor.
- Main equipment and materials should be in accordance with the Specifications and suitable to the works to be carried out.

The Contractor must submit, for each material and equipment that he proposes to incorporate in the construction, a full documentation to prove that it fulfils the requirements of the Technical Specifications.

- Control plan that the Contractor intends to implement, which should meet the Contract specifications and assure that quality is obtained.
- Number and Location of Hold Points (which needs a mandatory inspection before proceeding with the works) and Witness points (required by the Parties to verify, inspect and witness the process of work).

A.2.8 REVIEW OF TOPOGRAPHY AND SURVEYING

The Supervisor shall review and verify all methods and procedures, as well as the man-power, equipment and organization of the Contractor for carrying out topography and surveying Works. The Consultant shall request for verifications and cross checks, to be carried out in his presence, as deemed necessary.

The Supervisor shall carry out independently, as far as necessary, topography and surveying Works aimed to:

- Verify the local geodetic survey network;
- Dimensional control of the already built structures and setting out points;
- Document the progress of the works, their compliance with Construction Drawings and the quantities reported by the Contractor.
- Mapping of the underground works and excavations slopes.

The above tasks can be performed using modern technologies (like drones and laser scanning instruments).

The use of Drone, if possible, allows to acquire in short time a photo-mosaics of the entire surveyed area and a 3-dimensional model that can be used to generate contours map, slope maps, etc.... to be used for design, quantities calculation, documentation of work progress etc.

A.2.9 SITE SUPERVISION

The Supervisor will be required to mobilize and maintain on site throughout the entire construction and commissioning period the supervisory team, composed by Resident Engineer, Key Staff and support Staff. Before the starting of site activities (supposedly for a period of few months after the signing of the contract) the Project manager and the Key staff (in charge of Design Review coordination activities) will start the review of Contractor's Design as well as of all the Level 1 documentation to be provided by the Contractor (including Procedures, Programme, Quality and Management Plans) at home office.

The Supervisor shall define his Organization Structure, personnel's qualifications and specific assignments both at the Project Site and at the Home Office.

Whenever the Supervisor duty will be assigned by the Owner (intended as final Client of the EPC Contract) to an external international Consultant, typically the Consultant Organization Structure shall include staff supplied by the Client (Client Project Team).

The proposed general organization of the Supervisor for the EPC Contract Management should clearly reflect and show the relationship and communication flow between the Supervisor's Project Coordination Office and the EPC Contractor structure.

Supervisor's team shall supervise permanently all construction, hydro-mechanical and electrical equipment erection, testing, and commissioning operations in order to ensure the conformity of the Project and its portions to the Client's Requirements, Contract Conditions, Quality standards, applicable norms within the Time-Schedule foreseen in the Contract documents.

In addition, the Supervisor, through his technical personnel, shall carry out, whenever deemed necessary, in accordance with the progress of work, inspection visits to the site as well as to all Workshops and installations of hydro-mechanical and electrical equipment where Project components are manufactured, assembled, tested and /or prepared for shipment.

The Project Manager/Resident Engineer, with his team, will draft periodical Progress Reports and will develop a project administration system. Regular meeting will be scheduled with the staff of the Client and the Contractor. Reconciliation and grievance procedures will be established and finally all activities of backstopping and invoicing will be managed since the beginning of the project.

At the early stage of the assignment, the Supervisor will be responsible for the following:

- Development of Supervisor's Quality Assurance System;
- Development of project management information system;
- Development of detailed organization chart;
- Definition of methodology, timing and deliverables for the various activities;
- Creation of regular meeting schedule and setting of acceptance procedure;
- Monitoring and checking of design implementation;

-
- Setting up of Project filing system;
 - Development and installation an Environmental Management System;
 - Development and Installation of Project Management Approval System preferably a Web Based System;
 - Conduct a project Management workshop with the whole Project Management Team including the Client's Team at the start of the Contract;
 - Approval of the Baseline Schedule submitted by the Contractor;
 - Initial Project Management training for the Clients Project Team;
 - Approval of all initial project document submissions from the Contractor.

It is assumed that all official communications will be in writing. Verbal instructions could also be possible but the same will be confirmed in writing immediately. Minutes of all meetings drafted by the Project Manager will be kept and will be signed by the principal attendees as a true record of the proceedings of the meeting. These meeting records will provide a valuable reference if any controversy arises in the future.

Original outgoing and incoming correspondence together with attachments will be registered and filed into the main IN and OUT files and categorized as necessary (e.g. "for verification and comments"; "for information only"; "Verified, no objection"; "Verified, comply with comments"; "Verified, rejected: re-submittal required", etc..).

IN coming and OUT going correspondence will be stamped to identify the person who has drafted the letter and those team member that will receive it for information.

A.2.9.1 Testing

The Supervisor shall verify beforehand the program and procedures for tests to be carried out throughout the construction period. General testing principles, their frequency, typology, methodology, reference standards shall be reported in the Technical Specifications of the Project and detailed in relevant Method Statements and in the Inspection & Test Plan. Technical Specifications shall include the following principles:

- The Contractor will be responsible of all tests for the Quality Control to be performed in connection with the materials used for the construction of the Works.
- The Contractor shall supply, install, operate, maintain and remove at the end of the Works a site laboratory that will have to function as Quality Control of the Works.
- The laboratory shall be run by Contractor's personnel experienced in sampling and testing of materials, and quality control.
- The Contractor's laboratory shall be designed for performing most of the sampling and testing required in the Technical Specifications. Tests on samples and materials, which cannot be done at site due to impracticality of retaining such specialized equipment, shall be performed by reputable, competent and certified Quality Assurance laboratories.

- Quality Assurance of the Works shall be carried out by the Contractor who will manage the site laboratory.
- The Contractor shall be responsible for the handling and transport of all materials required by the Quality Assurance Laboratory.

Main tests to be verified by the Supervisor, before and during the execution of the works shall include, but are not limited-to, the following:

- foundation materials;
- RCC and its components;
- embankment materials,
- conventional concrete;
- shotcrete;
- grouting materials;
- steel bars, steel mesh, dowel, bolts, tendons, pipes;
- hydro steel structures,
- hydro mechanical/electrical equipment,
- materials and/or assembled parts, etc.

Some comments on the above tests are given in the Quality Control Section reported in the following paragraphs.

In additional, Third Party Independent Laboratory Tests shall be the responsibility of the Contractor when requested by the Supervisor. Third Party Independent laboratory service provider shall be approved by the Supervisor.

A.2.9.2 Quality Control of civil works

GENERAL

The civil works object of construction monitoring include:

- diversion works;
- RCC dam;
- spillway;
- Middle Level outlets;
- Intakes;
- Power tunnels;
- Gate Shafts;
- Surge shaft;
- Powerhouses;
- Outlet works;

-
- Switchyard;
 - Etc.

The Supervisor's experts will provide the following services:

- check progress of supply, works construction and all operations against contract program requirements, and request remedial measures by the Contractor in case of delays or other deficiencies;
- supervise and check all tests and other quality control measures required by the Inspection & Test Plan submitted by the Contractor, up to the issue of the final acceptance certificate;
- check the equipment and systems for the permanent works, including dimensional checks on fabrication details for installation and erection operations;
- issue special instructions to the Contractor in case of emergency and, if necessary, plan consequent measures with the Project Management;
- supervise proper performance of the Contract, including assistance in finding an amicable settlement of disputes and claims with the Contractor, avoiding resort to litigation and/or arbitration;
- give advice as dictated by the course of the works, including requests for modifications;
- accounting and administrative control: checking monthly measurements with the Contractor, verifying Contractor's monthly progress statements and accounts, and issue of monthly certificates of payment;
- issue of all provisional and final acceptance certificates for the works;
- prepare monthly and other reports.

The test types and the required frequency of testing will be provided in the Contract documents, provided that the Supervisor may review the testing programme based on the analysis of the results obtained.

The Supervisor will verify all results.

In all cases, samples will be representative of the "real" materials to be used in the Works and sampling will be carried out in accordance with the requirements of reference standards, or an approved equivalent.

The whole process of monitoring will be in accordance with the established and approved Quality Assurance Plan; non-conformities will be identified by the Supervisor and corrective action procedures initiated and subsequently monitored.

The process of day-to-day inspection and monitoring of the Works will generate routine instruction from the Supervisor to the Contractor as the essential tool of the Supervisor to exercise control for ensuring that quality and operational requirements are being maintained in accordance with contract conditions.

All instructions will be given in writing. Instructions pertaining to variations of the Works will also be issued in writing. Only in cases of emergency, the Contractor will be required to act on verbal instructions, which will be followed by written confirmations as soon as practicable.

The site staff will make the appropriate inspections and tests as the works progress and as may be offered by the Contractor for acceptance in accordance with the procedures established under the Quality Plan for the project. Independent audit checks, through visual inspections and material testing, will also be undertaken by

the Supervisor to verify that the QA records provided by the Contractor are in accordance with the statements being made by the Contractor.

In the following pages there are provided some notes on the major issues and Quality Control relevant to some of the most critical Works of Batoka Project that is the RCC dam. Comments on Underground Works are given in the paragraph relevant to Geological Inspection.

RCC DAM

Dam Project includes an RCC main dam with a gated spillway on the top of the dam and Middle Level outlets embedded in the dam body.

RCC is a technology that involves:

- Materials (cement, aggregates, admixtures, pozzolan, etc.);
- Equipment/plants (crushing plants, cooling system, batching plants, conveying system, etc.);
- Procedures (delivery, spreading, compaction, curing, joint treatments, cleaning, etc.)

and may present several interferences with other work phases like:

- Foundation mapping and treatment;
- Cutting of contraction joint;
- Positioning of waterstops;
- Lifting of formworks;
- Installation of instrumentation systems and embedded parts
- Etc.

To achieve the quality of the works and the planned production rates it is mandatory to guarantee a close coordination between all the parties involved in the activities mentioned above and an extensive knowledge of the various processes.

As detailed further on, the Quality Control Program of the Contractor shall include also:

- a Quality Control for the Staff Training and
- Training Courses for the RCC Staff and Workers involved in the execution of the works.

These training activities shall start before the starting of RCC placing activities in order to anticipate as far as possible the achievement of learning-curve peak.

This point is extremely important and sometimes under-estimated since, usually, the most critical phases in building an RCC dam are those occurring at the beginning of the works. Higher hydraulic loads and higher stresses in fact characterize the RCC placed at the bottom of the dam. In this zone, also the interfaces with foundation and its treatment are generally the most challenging.

The Contractor shall make available on site a suitable laboratory equipped for the manufacturing, curing and testing of a large number of RCC cylinders and define a detailed Mix design test programme to be carried out well before the start of placement of RCC and the starting of Full Scale Trials.

The aim of this test programme is to identify the most suitable mixes to be used in the different zones of the dam and to confirm the design parameters for the dam including but not limited to: uniaxial compressive strength, tensile strength, density, deformability modulus, VeBe time, initial setting time, thermal properties, etc.

Most complex tests, especially those related to the thermal properties of the mix, may be carried out in international renowned laboratories.

Technical Specifications and relevant Method Statement shall include the details and the sequence of all the main items that concur in the manufacturing of RCC, including:

- Cement (type (generally, Frequency of chemical, physical, hydration heat, tests from factory and on-site, transport and stockpiling facilities);
- Aggregates (Source, type and frequency of tests, acceptance criteria, aggregate production plants, shape, gradation, transport and stockpiling);
- Water, filler, admixtures;
- Layout of RCC plant, peak and normal capacity; methods and equipment for handling, mixing, transporting, spreading, compacting, curing, protecting and cleaning

Moreover, it shall be defined:

- Methods for temperature control;
- Criteria for Joint classification (e.g. Lift Quality Index) and relevant treatments;
- Sampling facilities;
- Programme of Full Scale Trials;
- Types and frequency of tests, both at batching plant and on site.

The Supervisor shall meet the Contractor during the execution of all these tests and shall possibly perform own and independent evaluation of test results, joints classification and mapping.

The Contractor shall establish and maintain an effective quality control program for RCC to ensure compliance with the Contract requirements and for maintaining records of control, including tests and inspections, their findings, and remedial actions taken when necessary.

The Contractor's program will be established and run under the supervision of a full time experienced Quality Control Engineer who will review and approve all activities concerning the production of materials, planning and scheduling of construction activities for placing RCC and the running and evaluation of RCC tests.

The RCC Quality Control Program shall include but not be limited to the following: aggregate manufacture and gradation, moisture, batching requirements and mix proportions at the batch plant, mix delivery, compaction,

joints (insuring adequate materials are on hand), embedded items, erection of precast facings, and all other tests and inspections required by Specifications.

Quality Control Program shall include also Quality Control Staff Training as well as RCC Staff and Workers Training Courses for the execution of the works.

Tests at prototype scale are essential to verify the "real" characteristics of RCC. In fact, the entire production process, from batching plant to dam site, clearly affects the final quality of RCC in such a way that laboratory tests or even Full Scale trials may be not completely representative of the real performances of the dam.

In this sense following kind of tests are recommended to be carried out on site to better characterize the RCC dam:

- Large scale shear block tests on samples taken directly from the dam body using large diameter diamond circular saw;
- Detailed log of RCC cores drilled periodically in the dam body and statistical analysis over the distribution of segregated area, bonded on not-bonded lift-joints, etc.;
- Laboratory tests on RCC cores drilled in the dam body, including UCS, direct tensile strength, lift-joint shear strength, permeability;
- Mapping of U/S face of the dam soon after formwork removal in order to detect any defect;
- Mapping of dam permeability at large scale, executed by means of water tests on dam drain holes.

The above kind of prototype-tests can be required to be included in the RCC Quality Plan of Contractor.

A.2.9.3 Quality Control of Hydro-Mechanical and Electrical equipment

As indicated in the previous sections, the Contractor will submit, for the Supervisor's approval, the Detailed Design including all detailed data, calculations, explanatory documents and drawings necessary for manufacturing and testing of the Hydro-Mechanical and Electrical equipment.

These documents, duly reviewed by the Supervisor, should form the basis of the contractual procurement of the equipment from the manufacturers.

It is expected that the information to be supplied by the Contractor, and verified by the Supervisor during this phase, will include the following items:

- Hydro-mechanical Equipment:
 - up-to-date layout;
 - hydraulic design calculations for the full range of operations;
 - stress analysis of components;
 - tables with characteristics of main parts (flow, dimensions, weight, etc.);
 - critical operating conditions;
 - sequences, time, methods for assembling parts and erection rigs characteristics;
 - materials to be used for the various elements of the supply stating their durability;

-
- maintenance ways and ease of performance;
 - quality control tests and operation safety.
-
- Hydro-electric Equipment:
 - up-to-date layout;
 - design calculations for stress bearing structures;
 - tables with final rating of main parts;
 - sequences, time, methods for assembling parts and erection rigs characteristics;
 - turbine critical speed;
 - requirements for unit bearings;
 - characteristics of cooling systems;
 - transport fittings and protections;
 - materials to be used for the various parts of the supply stating their durability;
 - quality control tests;
 - maintenance ways and ease of performance;
 - operation safety.

 - Electrical Equipment:
 - generator design;
 - materials and technology;
 - quality control tests;
 - equipment ratings and test certificates for major plant components;
 - fault level calculations;
 - voltage regulation analyses;
 - reactive power control;
 - motor characteristics, duty cycle, starting performance of major and essential;
 - auxiliaries, selection of power cable ratings;
 - insulation, segregation and separation of power and control cables;
 - fire prevention measures;
 - design, types, performances and characteristics of HV equipment and electrical devices;
 - single line diagrams;
 - design and calculation of connection to HV line and substation.

 - Electrical Instrumentation and Control:
 - compatibility among different suppliers' equipment and layouts;
 - P&I diagrams;
 - interface with ICS/LDC remote dispatching systems, if any.

The Supervisor will follow the different phases of the detailed design and will oversee the activities of the Contractor, as well as investigations and inquiries realized at site.

The Supervisor review will consist in examining the various documents to verify the:

- correct and adequate selection of materials depending on their specific destination and according to the Client's Requirements and international practices;
- proper dimensioning of the various parts with calculated maximum stresses within internationally accepted limits for the various load conditions and cases;
- appropriate construction design of main equipment adopting latest high-quality practices and especially facilitating assembly and future maintenance;
- satisfactory choice of performances and ratings of different components, with sufficient safety margins and adequate overcapacities to improve reliability;
- proper interface of the equipment with the 1st phase concrete.

MANUFACTURING

During manufacturing, the Supervisor will check the quality sensitive activities in the Contractor's Head Office, in the Manufacturers' workshops and at the construction site, reporting any significant discrepancies and suggesting corrective follow-up actions.

It will be required to verify that the inspection procedures submitted comply with Contract requirements and with specified quality standards of internationally accepted codes.

In particular, the controls will encompass:

- planning procedures;
- document control;
- verification and control of materials, parts and components, welding capability of specialists;
- control of welding and/or special processes;
- inspection for test control;
- control of measuring and testing equipment;
- handling, storage and transport records.

In order to achieve the above, the Supervisor will undertake the following actions:

- review the Quality Management System of the Manufacturers;
- inspect, where necessary, the major equipment and components during manufacturing at the Manufacturer's factories;
- evaluate the test results for materials and respective certificates issued by the Manufacturer's suppliers. Should critical situations be identified, the Supervisor will prepare a specific report on the matter in order to allow the Owner to take action;
- coordinate, expedite, schedule and report results of workshop inspection visits.

Sufficient records will be developed and maintained so that the results of the inspection are easily identifiable and traceable.

Before starting the construction works, the Supervisor will conduct inspections, audits and factory tests witnessing of materials and equipment during the manufacturing and procurement phase, with particular attention to type tests and acceptance of the main components, as well as "routine" and "sample" test relevant to the prototypes, ensuring the satisfaction of the features requested by technical specifications.

The Supervisor will participate in factory testing of major equipment, and preparation of corresponding acceptance certificates. The main equipment subject to this monitoring activity will be determined by agreement with the Supervisor.

The Contractor will submit the detailed program of work developed in all its phases (project, production, transportation to site, installation and testing) for verification and validation. Finally, the Supervisor will make sure that necessary operation and maintenance manuals, documentation, training, etc. are supplied by the Contractors to remove bottlenecks and expedite shipment

The Supervisor will review the results of the turbine model test report, to assess that the guaranteed equipment characteristics and performances have been satisfied in respect to the EPC Contract, as well as to confirm that the operating characteristics of the proposed machines are within acceptable levels.

In addition, the Supervisor will review and approve results of the Spillway Model Test.

SITE INSTALLATION AND ERECTION

The Supervisor will supervise the Contractors' activities for the installation of the electrical, electromechanical and hydro mechanical equipment since their arrival on site up to their commissioning. Basis of this activity will be a work breakdown structure whereby the entire project is broken down into successive small phases.

A schedule will be built up for each project section (e.g. power house equipment, substations, etc.). At the outset, the schedule will be set up based on the submitted contractor's schedule.

Whenever dam and power houses fall within different contracts and contractors, the schedule of each work will be coordinated with the others, and possible interferences and interconnected activities prescribed to be managed accordingly.

The schedule will identify the critical path and will be regularly updated as construction proceeds. Should maintenance of the critical path be endangered, the schedule will facilitate early recognition of this so that corrective action can be implemented in good time.

Once the schedule has been established and construction is in progress, our on-going work relating to this activity comprises monitoring and controlling. During the execution of the works, the Supervisor will closely check all operations so that those items not complying with the requirements are identified and consequent corrective actions suggested; where necessary, action will be taken to prevent recurrence of nonconformity conditions. During the implementation of civil works and installation of electrical, electromechanical and hydro-mechanical equipment, the Supervisor will closely monitor the progress of each phase of the Project.

The Supervisor will monitor the progress of the activities to have a complete, overall picture of the situation and agree on the activities to be performed.

During the supervision of erection, the Supervisor will check and validate the course of the implementation of the work, the compliance with the project and with the contracts and the quality assurance of:

- temporary structures built in situ;
- work schedule;
- possible additional work;
- any recommended changes required by the Supervisor;

and will perform the following activities:

- interpretation of drawings and specifications for the conformity of assembly work to contract;
- checking of the test procedures for facilities and equipment;
- consideration of any changes in the field that may be required;
- monitoring progress in respect to milestone dates and events;
- coordination and inspection of the detailed installation activities to ensure continuous and effective progress of all work and ensure compliance with specifications;
- monitoring and verification of all testing and other quality control measures required by the contract until the issuance of the Performance Certificate.
- Monitoring of the Contractor activities in respect to the compliance with local and international site safety and environment standards and regulations.

A.2.9.4 Geological Inspection

The following general principles shall be followed during the implementation of the works related to excavation activities:

- mapping methodology, procedures and their representation in a graphical format will be primarily checked, reviewed and agreed with the Supervisor, who shall have a geological team available to make visual inspections of all excavations jointly with the Contractor as well as independently;
- the Supervisor shall ensure that the geological mapping will be carried out both for open air excavation and underground excavation beforehand the excavation itself is covered by embankments, concrete, temporary and permanent support works etc.;
- the Supervisor has to ensure that no foundation surface shall be covered by any material before the mapping mentioned in previous point has been approved and the prescribed treatments of excavated surfaces completed;
- The Supervisor's geological team, together with the Supervisor's Resident Engineer, shall give all recommendations to the Contractor(s) for the re-design of foundations due to un-foreseen rock conditions in the course of excavation, if needed.

UNDERGROUND WORKS

As far as power waterways tunnels excavation is concerned, the Contractor will carry out a comprehensive investigation campaign in order to obtain sound geotechnical parameters and a safe design, which will include:

- excavation methodology;
- excavation phasing;
- monitoring system (e.g. convergence);
- temporary support works;
- permanent support works.

The Supervisor will:

- review the investigation program and test results;
- review Contractor's design;
- perform periodical geo-structural inspections during the tunnel excavation phases in order to verify the geotechnical classification of the various stretches and the appropriateness of the temporary and permanent supports designed by the Contractor.
- perform periodical inspections to verify that the as-built corresponds to the design;
- perform rock-bolts pull out tests
- check tunnels sizes and verify their dimensional accordance with the project;
- Perform a topographical survey of the tunnels alignments;
- Analyze data of the monitoring system.

OPEN AIR EXCAVATIONS

Surface surveys are required to control the status of works and the geological conditions of the foundations. As explained in previous paragraphs, the possibility to make use of drones for the survey shall be explored, and welcomed, since it allows to obtain georeferenced photos of the inspected area and a Digital Terrain model, allowing to obtain a complete 3D model of the surveyed area elaborating all the sequential photos with engineering software.

Combining the site investigations (visual inspection, Schmidt hammer, geophysical tomography at small scale, etc.) with the superficial survey, it is possible to evaluate the main mechanical characteristics of the rock, such as:

- GSI (Geological Strength Index);
- RMR (Rock Mass Rating)
- Uniaxial Compressive strength
- rock type;
- degree of weathering of the rock;
- discontinuities in rock mass;
- etc.

and record them in a geo-referenced 3D database.

Drone and geological survey are generally carried out in local areas of limited extension, following the progress of the excavation works.

Since the information acquired with the proposed methodology is geo-referenced, it is always possible to assemble the local mapping in larger scale drawings obtaining a useful view of the foundation geology at the scale of the project.

A.2.9.5 Monitoring, Instrumentation System and Emergency Preparedness Plan

About this topics reference shall be made also to other dedicated sections of this Dam Safety Plan.

The detailed design of Monitoring and Instrumentation systems shall be carried out by the Contractor (requirements of the Instrumentation system are to be detailed in the Final Design phase) and verified by the Supervisor.

Supply and Installation of Instrumentation system shall conform to the following principles:

- instrumentation shall be of high quality, realized according to the best practice and international standards.
- all the instruments shall be subject to Contractor's acceptance procedure of inspection and testing at their arrival at the Site.
- acceptance of the instrumentation devices after installation shall derive from special procedures to be defined by the manufacturer/supplier and agreed with the Supervisor.
- testing, calibrating, installing and commissioning of the monitoring system shall be provided by supplier's skilled and qualified personnel, under the Contractor's coordination.
- all instruments shall be accompanied by Technical Specifications, Procedures for the installation and use; calculations and interpretation of the measured data (calibration curve, calculation formula and form, example of calculation); acceptance testing procedure and maintenance manuals (including list of recommended spare).

Design and review of the instrumentation system shall be ready before the commencement of the works in order to anticipate the identification of any possible interference with civil works and to plan all the installation facilities for correct placement and wiring connections of the instruments.

Moreover, some instruments shall be installed from the early stage of works in order to acquire all the necessary data regarding the performance of the Project.

The Supervisor shall review the Monitoring and Instrumentation system considering the guidelines suggested by international codes and standards such as:

- "Instrumentation for Concrete Structures" US Army Corps of Engineer, 1987;
- "Embankment Dam Instrumentation manual" USBR, 1987

-
- "Instrumentation of Embankment dam and levees", US Army Corps of Engineer, 1995;
 - "Automated dam monitoring system", Icold bulletin 118, 2000
 - "Dam foundation: Investigation, treatment and monitoring" Icold bulletin 129, 2005

Of course, the Supervisor will make use of his expertise to tailor the Monitoring System to the specific requirement of Batoka project.

The Supervisor shall be involved at the initial readings of each instrument to ensure that the methods and procedures used are correct and allow the determination of reliable "zero" values.

The Supervisor shall verify that the readings are carried out at the prescribed times and intervals, the procedures and methods of reading are correctly applied, and results are correctly registered, filed and analysed. During the First Impounding phase, as detailed in the First Impounding Programme, the rate of readings shall be increase and the data shall be elaborated in real time in order to verify the thresholds values corresponding to Alert and Alarm conditions.

Finally, as normal practice, the Emergency Preparedness Plan shall be reviewed and finalized by the BOT contractor.

A.2.9.6 Monitoring of Construction schedule

All what follows can be refined and adjusted if and when one or more contracts will be set for the construction of Batoka Project. In the case Dam and Power Plants are allocated to different Contractors, relevant construction programmes shall be analysed separately as well as together as far as possible interferences and dependences are concerned.

What follows is referred in general to the monitoring activity of the construction schedule(s).

The Supervisor shall check that the Contractor maintains a proper organization of the Works in all phases in order to keep the targets of the General Work Schedule and the final commissioning of the plant.

The Supervisor shall alert the Contractor in due time, whenever the Supervisor foresees any risk of delay and shall request the Contractor to re-analyze the programs and sequences of Works. The Supervisor will suggest partial or general adaptations of the program whenever deemed necessary.

Particular attention shall be given to the co-ordinations of the activities that imply interfaces between civil works, hydro-mechanical, electro-mechanical and mechanical equipment.

In order to ensure all the activities commented upon here above are correctly, timely and efficiently carried out by all parties, procedures and schedules for meetings on site shall be established in due time. The Supervisor shall be responsible for the enforcement of these procedures and schedules once they have been mutually agreed upon.

The basis of Monitoring activity is a work breakdown structure whereby the entire project is broken down into successive small working lots, typically over five levels as follows:

- Level 1 – Project Section;
- Level 2 – Task;
- Level 3 – Sub-Task;
- Level 4 – Work Package; and
- Level 5 – Individual Work Items.

A schedule will be built up for each project section (e.g. Diversion Works, Dam, Intakes, Tunnels, Surge Shafts, Spillway, Bottom Outlets, Power Houses, Switchyards, etc.), starting from Level 5 work items and the successive upwards aggregation to the higher levels. At the outset, the schedule will be set up based on the Contractor's submitted schedule.

The schedule will identify the critical path and will be regularly updated as construction proceeds. Should maintenance of the critical path be endangered, the schedule will facilitate early recognition of this so that corrective action can be implemented in good time.

Once the schedule has been established and construction is in progress, the Consultant shall:

- monitor the rate of progress for any given work item and the amount of resources required to achieve this rate;
- control and evaluate the data received from the monitoring process to identify the necessity of any action.

Monitoring and control thus give input to planning and result in a cycle (planning-monitoring- control-planning- etc.) which is continuously repeated throughout the duration of construction.

The Supervisor will periodically monitor the progress of the activities so to have a complete, overall picture of the situation. A valid instrument to carry out the monitoring of the progress of works will be the monthly reports and any other necessary report, as detailed below:

- Inception Report;
- Monthly Progress Reports (suggested to be integrated with short-duration drone videos);
- Quarterly Progress Reports;
- Annual Reports;
- Reservoir Impounding reports;
- Final report before waterway system filling;
- Waterway system filling report;
- Commissioning acceptance test reports;
- Specific reports on special cases as required;
- Claim assessment reports;
- Supervisor's site and home office periodic activity reports;

-
- Project Final completion report;
 - Defects Notification report.

A.2.9.7 Commissioning programme

The Contractor shall prepare the detailed programme of site tests with the overall goal of clearing the way to a successful introduction of the plant into the existing interconnected system. The programme shall outline the approach and methodology of the start-up operations, and will be subdivided in subsequent phases:

- Pre-commissioning tests;
- Commissioning tests;
- Trial operations and
- Performance and efficiency tests.

Prior to the execution of this programme, the Contractor should submit also a preliminary version of all as-built drawings and of Operation and Maintenance (O&M) Manuals.

Throughout the commissioning stage of the Project, the Supervisor will provide a Commissioning Manager and specialists in the applicable engineering disciplines to support the activities related to commissioning, performance tests and transfer to the Owner structure of systems and equipment.

The programme should define the areas of responsibility and detail technical, administrative and safety procedures. It should also define the principles for the technical requirements associated with the commissioning of individual components or of systems, including the use of commissioning check-lists to record the checks made and the tests undertaken, the results obtained, the signatures of the EPC Contractor commissioning, Specialists and of witnesses from the Supervisor and his commissioning staff.

The Commissioning Programme to be submitted by the Contractor should also include the procedures for performance and guarantee acceptance tests, specifying acceptance criteria, test parameters, instruments to be used and instrument accuracy requirements.

Moreover, all Commissioning Programme shall be approved by the Supervisor in consultation with the Client before program execution.

The Supervisor staff, will review the Commissioning Programme and the attached procedures, checking that design requirements are complied with, methods proposed are suitable to keep operations under control and all necessary verifications are carried out.

The Supervisor shall verify that all relevant parts and components are ready for the various tests and check periodically that the time-schedule to achieve critical steps of the programme are maintained, prescribing all the remedial actions required to minimize the risk of delay.

A.2.9.8 Reservoir Impounding

The First Impounding Plan (FIP) coordinates the work activities following the closure of the river diversion and, consequently, it deals with the reservoir filling, the work scheduling, the instrumental monitoring of the dam behaviour and the procedures to be adopted according to the most likely foreseen scenarios occurring during the reservoir impoundment.

Before the implementation of the First Impounding Plan the Supervisor shall receive and approve the Reservoir Operation and Maintenance Manuals prepared by the Contractor, verifying that the procedures described in the FIP are coherent with those indicated on the manuals.

The First Impounding Plan report will be structured in a similar manner to the example given below:

- **KEY ROLES**

This chapter will describe the individual roles and responsibilities of the figures who will be involved in the first impounding procedure. In particular, there will be Dam Safety Committee (DSC) that will implement the Dam Safety Program (DSP). The DSC will be responsible for all the activities related to the safety and safe performance of civil works and equipment of the project and will involve delegates of Owner/Supervisor and Contractor any other authority indicated by the Owner or Stakeholders involved.

- **DEFINITION OF THE CONDITION READY TO START**

This chapter will describe all the recommended pre-filling conditions.

In particular:

- a reliable Monitoring System shall be set up and tested before the start of impounding in order to evaluate Dam behavior under impoundment.
- All the equipment and manpower necessary to proceed with the plugging of Diversion works shall be available on site.
- All the devices necessary to release ecological flow, control the rising of the reservoir levels, protect the sensitive areas or portions of the works shall be ready and fully operative.

The readiness for the start of impounding activities will be verified by a joint inspection of the DSC based on the recommendations given by the Supervisor.

- **DESCRIPTION OF THE IMPOUNDING**

When all the activities indicated in the previous chapter have been correctly carried out, the DSC orders the start of the impoundment.

This phase of impoundment will proceed to the full filling of the reservoir or pre-defined target levels unless differently prescribed by DSC based on the observed behavior of the dam.

During the impounding all required measurements will be made (deformation, settlement, seepage, etc.) by the Contractor at the presence of the Supervisor and transmitted to the DSC.

The estimate time to perform the impounding of the Batoka Reservoir ranges between 4/5 months considering the below listed conservative hypothesis:

- Beginning of the impound process during the dry season (from November to February)
- Guarantee the environmental release in accordance to the ESIA requirements

Considering the above listed conditions and the time necessary to impounding, it possible assume that the impact of the impounding of Batoka Reservoir is negligible on the Kariba Reservoir.

- **CONTROL PLAN**

This chapter will describe the recommendations for the acquisition of measurements, which allow assessing the behavior of the dam and of the main works and to verify the hypothesis at the base of geotechnical/hydrogeological/structural models assumed at the design stage, particularly:

- level of the reservoir;
- seepage (dam drainage);
- seepage turbidity;
- piezometers readings;
- embankment settlements;
- inclinometers readings;
- topographical survey of the dam structure;
- etc.

- **INSPECTION PLAN**

This chapter will describe the inspections that will have to be carried out with regard to the works and downstream of Batoka Plant

- **ROUTINE and ALERT CONDITIONS**

This chapter will describe the normal and threshold values of the monitoring instrumentation. The following procedures will also be defined:

- Routine Procedure;
- Alert Procedure;
- Controlled Drawdown Procedure;
- Emergency Drawdown procedure.

- **CONTINGENCY PLAN**

Finally, this chapter will describe the plan of action to be taken in case of an impending catastrophic failure of the dam or a large and sudden release of stored water.

The Supervisor shall verify and approve the sequence of operation described in the First Impounding Plan to proceed with First Impounding, including monitoring program, definition of routine and alert conditions etc. and shall actively participate to the impounding process through the Dam Safety Committee.

Some of the aspects above described are already developed, at feasibility design stage, in other sections of this Dam Safety Plan.

A.2.9.9 Testing and Final Control of Equipment

The Supervisor, under the guidance of the Commissioning Manager, will take note of any faults or defects detected during the commissioning tests performed by the Contractor(s) and will monitor the interfaces with the plant operation.

Commissioning and testing procedures will include acceptance criteria, test parameters, instruments to be used and instrument accuracy requirements.

The commissioning tests will include performance, functional and operational tests. Tests on completion should usually be carried out in the following sequence:

- pre-commissioning tests, including appropriate inspections and dry or cold functional tests to verify the physical reliability of the individual equipment elements and their ability to function within their respective systems as per design;
- commissioning tests, including specified operational tests to demonstrate that the works or sections of them can be operated safely and as specified under all normal and exceptional operating conditions;
- trial operation tests (Trial Run), to demonstrate that the works or sections perform reliably and according to the contractual conditions and requirements.

At the completion of the erection and installation works, the Contractor will start carrying out the "dry" (or "cold") and "wet" functional tests, in accordance to the program submitted for the Supervisor approval.

The Supervisor is called on the field to carry out, jointly with the Contractor, the so-called "Final Inspection" of the installed equipment and plants. The aim of this inspection is to verify the compliance of the erection works to the project requirements, and to identify those items, which need small adjustment, settings or fine-tuning in view of the first energization and Trial Run of the plant.

Acceptance certificates will be issued by the Supervisor at the end of the successful acceptance tests of each unit and at the commissioning of any facility.

Acceptance Committee, consisting of delegates members from the Supervisor and the Contractor will be set up to fulfil these tasks. The Supervisor is responsible for all the preparatory verifications prior to the commissioning. Ministry of Energies of the power plant country who issues these certificates of acceptance, have typically the mandate to oversee that the facilities:

-
- conform with the approved final design and with the regulations and standards applicable internationally,
 - can be integrated to the national grid
 - are secured with respect to safety.

A.2.10 SERVICES DURING DEFECT LIABILITY PERIOD

What follows is a general guideline that shall be adapted to the type of construction contracts that will be put in place.

During the Defects Liability Period (DLP), when the Contractor is typically bound by the Contract to remedy any kind of defective works by his fault, the Supervisor will make available his own experts for hydro-mechanical, electrical equipment and Civil Works.

Supervisor' specialists will inspect the Works to determine precisely the actions that the Contractor took in accordance to the Contract and will inform the Contractor in writing about this.

During the Defects Liability Period the Supervisor will acting closely to the works for:

- the finalization of the remaining works at the date stipulated by Contract (List of Outstanding Works at the Taking Over);
- rectification of all defects during the warranty period with issuing of clearances for defects rectified as well as a prolongation of warranty for major parts, if applicable. The punch list is updated on the basis of the progress of the Contractor's activity
- preparation of a project completion report, which acceptance imply the end of the Supervisor's assignment versus the Contractor;
- overseeing compliance to contractual obligations;
- fixing of all the defects and the damages caused during the Defects Notification Period.

The Supervisor will carry out inspections as necessary, after commencement of DLP, and will prepare brief reports on any issues or defects discovered / repaired by the Contractor. Should be necessary, the Supervisor could require repetition of any test and check to be carried out by the Contractor. The Supervisor is also called to witness tests and accept relevant documentation.

The Contractor will update, accordingly to any repair work executed, the as-built drawings, documentations and O&M manuals.

The list of the remaining works to be executed during the Defects Notification Period is mentioned at the Taking-Over Report; these works should be completed within the respective deadlines. The Supervisor will monitor and notify the Contractor about any defects occurred during the Defects Notification period.

The Supervisor will inspect and verify the completion of the remaining as well as the remedying works to be executed. He will monitor the maintenance works recommended in the Operation and Maintenance Reports for the Defects Notification Period, elaborated in accordance to the Supervisor recommendations.

The Supervisor, following the approved procedures, will assist in the issue of the Final Acceptance Certificate at the end of Defects Notification Period (DNP) with respect to:

- Completion of Outstanding works as listed in the report which accompanies the Taking Over certificate;
- Listing of Construction Works with defects;
- Time schedule and activities of remedial actions
- Failure of the contractor to remedy defects;
- Conditions for approval of the site demobilization;
- Current stage of existing demands and claims;
- Previous conditions for the issuance of the Final Acceptance Certificate (FAC)

The Supervisor will ensure that the conditions for the issuance of the Final Acceptance Certificate (FAC) are accomplished at the end of the Defects Notification Period.

A.2.11 HANDLING OF CLAIMS

What follows is a general guideline that shall be adapted to the type of construction contracts that will be put in place.

The Supervisor will provide all efforts to settle any conflict with the Contractors. In case any dispute, controversy or claim arise with the Contractors relating to or arising from the relevant contractor's agreement (contract), or the breach, termination or validity thereof, the Supervisor will be aimed to resolve such matters amicably through negotiations.

Should such negotiations not lead to a mutually acceptable resolution of the dispute, the dispute, controversy or claim shall be settled according to the general conditions of contract and/or special conditions of contract. The Supervisor will verify that notice of claim has been given in due time after becoming aware of the situation giving rise to the claim. Should the notice be given too late or be not supported by the required information, the Contractor will not be entitled to any extension of time or additional payment.

After the inspection, the Supervisor will prepare an assessment of the Contractor's contemporary records and with his preliminary conclusions about the potential outcome of the claim and will define any instruction to issue to the Contractor about further contemporary records.

A.2.12 MANAGERMENTS OF PAYMENTS

What follows is a general guideline that shall be adapted to the type of construction contracts that will be put in place.

The Contractor is generally required (for instance as per typical FIDIC Conditions of Contract) to submit periodic applications for Interim Payment Certificates, together with supporting document and calculations, of the value of Works executed for which he considers himself entitled to payment. Each application should be based on the joint measurement and agreement of quantities of work performed by the Contractor and accepted by the Supervisor.

The Contractor will be required to submit progress payment requests, based on measurement, on a scheduled basis (usually monthly) throughout the construction phase. The supervision team will maintain adequate records to review and check the measurement and progress payment requests in detail. The supervision team will also review payment requests and prepare payment certificates recommending that a certain progress payment amount is due.

FIDIC places responsibility upon the Client and his Client's Representative (if any present) to perform a measurement after reasonable notice from the Contractor that he requires any part of the Works to be measured for purpose of interim payment.

FIDIC requires the Contractor to attend and assist the Client's Representative in making such measurement, failing which the Contractor has limited opportunity to dispute the Client's determination. In practicality and to avoid disputes the Supervisor will establish procedures whereby the intent will be jointly to perform and agree the measurement prior to the Contractor's submission of each and every monthly statement.

Based upon the information he has gathered during the month in question, and in accordance with the Conditions of Contract, the Client's Representative will determine monthly interim conformity to payment certificates for work completed and approved. Parallel with these activities, the Contractor is required to submit to the Client's Representative monthly statements, supported by relevant documents, calculations, sketches and drawings, of the works executed for which he considers himself entitled to payment.

In his preparation of Interim Payment Certificates, the Supervisor will apply the Contract provisions in respect of:

- schedule and percentages on the Bill of Principal Quantities of the Permanent Works established for civil, hydro mechanical and electrical Works stipulated in the EPC contract
- provisional and Lump Sum items;
- value of any day-works performed for which the Supervisor has issued prior instructions;
- payment for work undertaken by nominated sub-contractor(s) (such payment requires evidence that prior payment has been made to the nominated sub-contractor(s));

-
- materials on site;
 - deductions in respect of recovery of any Advance Payment made to the Contractor;
 - deductions in respect of retention monies;
 - application of any adjustment factors allowed for in the Contract to allow for escalation of prices;
 - deduction in respect of any statutory taxes or levies applicable under the Contract;
 - deduction in respect of any Liquidated Damages applicable;
 - any corrections required to previous Interim Payment Certificates;
 - any interest to which the Contractor is entitled as a result of previous late payments; and any other costs to which it has been determined that the Contractor is entitled; for example claims and/or extensions of time.

The Supervisor will ensure that Interim Payment Certificates will be fully supported by back-up calculations (and sketches where necessary) indicating the location and scope of works measured and certified for payment.

After receiving the Performance Certificate, the Contractor shall submit to the Supervisor a draft of the final statement with supporting documents in an approved form indicating the value of the works done in accordance with the Contract and any further sums that the Contractor considers to be due to him under the Contract.

After the review of the Supervisor, the Contractor could be requested to provide additional information and then prepare and submit the Final Statement.

A.2.13 TRANSFER OF KNOWLEDGE

The optimal management and operation of dams over the years can be pursued only by employing highly qualified engineers and technicians and with a broad experience.

In the case the Owner will recur to the assistance of an international consultancy firm for Batoka Supervision, the training program and transfer of knowledge and technology are important aspects of such assignment.

The main goal of this task is to use the opportunity of the Design Review and Construction Management Supervision of Batoka Plant to transmit the international experience of the hired experts to Client Project Team staff nominated by the Owner.

What above and what follows is indicated for the Dam Owner, but as far as necessary in the case different contracts are put in place for the two Plants of Batoka Project, the guidelines provided can be applied for specific training activities for each of the Plant (and relevant Owners or operators).

In that case what is most important is that the Consultant will provide an on-the-job training to the Client's personnel on all aspects of the Consultancy during construction and commissioning stages, as illustrated here below.

Furthermore, the training program will be composed of workshops and presentations where not only Owner's Project Engineers and technical staff but also external personnel, for example, university students may actively participate.

A.2.13.1 Approach and Methodology

At the beginning of the assignment, the international Consultant will establish an updated training program for Owner's approval. The timing and content of the training program can be modified at Owner's request in order to benefit in the best possible way the transfer of knowledge at different stages of the project implementation.

The organization of the training program will basically include three major activities:

- on-the-job training to personnel of the Owner to ensure hands-on experience during construction and commissioning of the dam;
- presentations carried out by Consultant experts during their missions on site;
- technical workshops at the different milestones of the project

A.2.13.2 On-the-Job Training to Owner's Personnel

This activity will be carried out through continuous day-to-day collaboration of Owner's staff and consultant's experts, working together at the site.

The Owner will typically provide a Core Team of Assistant Engineers plus an Additional Staff of Assistant Engineers to participate to the Consultant's project team while working at the project site.

The training program will be designed specifically to the needs of staff. The rhythm and style of learning will be adapted to the needs of participants.

The training will be supported by examples from the concrete experience of the Consultant, illustrating the critical aspects encountered in the implementation of major dam projects. The presentation of existing cases will be extremely useful for the transfer of knowledge and will be done using videos, photos, drawings, diagrams, etc.

During these on-the-job training sessions, engineers will transfer to their counterparts the technical knowledge on many aspects related to construction, assembly, testing and commissioning of hydropower plants and transmission lines.

This on-the-job training will be specifically organized in different phases of the assignment, in order to include the following key aspects especially valuable for the construction and commissioning of the dam but also administration of the works contract:

- General Dam Engineering, in particular foundation treatment, RCC dams, embankment dams;
- Geotechnical mapping of underground and open-air excavation;

- Electrical and Mechanical engineering;
- Hydraulics of spillways;
- Dam Monitoring and Maintenance;
- Site supervision, management of claims during dam construction and dam rehabilitation projects;
- Quality Assurance Plan procedures during dam operation and maintenance
- Optimization of the design of the main components of the project;
- Environmental and social issues related to construction supervision, best international standards.

Moreover, during construction controls, the Consultant can train the Owner personnel on use of instruments (such as Differential GPS, drones, sclerometres, Permeameters, Flow measurement vessels, etc.).

A.2.13.3 Workshops and Presentations Carried out by Consultant Experts

This activity will be carried out especially through the presentation of case histories experienced by the Consultant that can be similar to the Batoka Project case.

It will be defined in collaboration with the Owner the detailed program of the proposed workshops and short presentations, considering the field specializations of the Owner's personnel and Owner's needs.

A.2.13.4 Technical Presentation at the Different Milestones of the Project

For each milestone of the project the findings of all the Consultant's activities will be illustrated through a specific presentation to which will follow a debate/discussion.

Together with the main findings of the studies, the most critical aspects will be especially illustrated in detail.

PART B - INSTRUMENTATION PLAN

B.1 INTRODUCTION

B.1.1 CONTENT AND STRUCTURE OF THIS PART

This is the **PART B "INSTRUMENTATION PLAN"** of the Batoka Dam Safety Plan.

This part of the document outlines the operation and maintenance activities and procedures relevant to the Batoka Dam MONITORING SYSTEM.

It describes the monitoring system of Batoka Dam, and it contains the instruction for measurements to be collected by the instruments, for their presentation, use and assessment.

The part B is divided in two sections:

- **DAM INSTRUMENTATION OPERATION AND MONITORING**
describing (at feasibility Design level) the Batoka instrumentation and the monitoring activity.
- **DAM INSTRUMENTATION MONITORING RESULTS ASSESSMENT**
providing indications on how to deal with the results collected by the instruments, together with some guidelines for the instrument monitoring assessment.

The drawings showing the location and relevant bill of quantity of the instruments foreseen will be provided in the feasibility design report.

This document shall be integrated and developed, when the detailed design and construction will be carried out, annexing the following:

- Detailed design of Batoka Plant instruments
- As-Build drawings showing the location and name of each instrument
- Instruments installation sheets (Manual and Automatic)
- Instruments data sheets & manuals
- Instruments Calibration sheets and certificates
- Software manuals

This part of the report is in fact specifically focused in the instruments monitoring activities. The whole Operations and Maintenance Plan for the Batoka Plant is provided in the Parts C and D of the report, to which reference is made for all the operation and maintenance activities and procedures relevant to the Batoka Plant.

B.2 DAM INSTRUMENTATION OPERATION AND MONITORING

B.2.1 INTRODUCTION

This chapter describes the monitoring activities that shall be carried out during the operation of the Batoka Plant.

They are referred to the period of operation of the plant, they are applicable also for the dam construction and first impounding periods (as far as applicable), for which any further specific instructions can be added during the detailed design and construction process.

In the following paragraphs the instructions dedicated to the dam instrumentation monitoring for the plant operation period are provided, describing which measures shall be carried out with which instrument, where and when.

In the next chapters there are indications on how to evaluate the results gathered by the instruments, and the instructions on how to proceed in case of routine or alert conditions.

All that follows is at feasibility design stage of knowledge, therefore to be considered preliminary and to be detailed and updated before coming into operation.

B.2.2 INSTRUMENTS CONTROL PLAN SUMMARY TABLE

For an easier control and implementation of the monitoring procedure a summary table is to provided indicating all the instruments to be used on site, along with the type and frequency of measures to be carried out.

Here below a format for this table is provided, with first indications on instrumentation, to be integrated during the detailed design and construction process.

The instruments object of monitoring, that will be recalled in the table below, are assumed will be illustrated in detail in relevant drawings before the plant enters in operation, and will make part of this document and will provide, where possible, indication of the number and position of each type of instrument installed. All the as built instrumentation drawings will be documented inn dedicated documents.

All the prescriptions mentioned in the table and in the following paragraphs refer to the standard systematic monitoring activities. Prescriptions can be modified as needed if measurements show some anomalous trend or some indication of concern for the dam stability.

The routines conditions and alert conditions are detailed in the second paragraph of the next chapter.

Initials	Instruments Type	Position			Scope	Notes	Monitoring schedule (1)		
		Area	Ref. dwg	Elev.			Routine	alert	
				m a.s.l.					
WL	LS	LEVEL STAFF	Dam upstream face	(*)	(*)	reservoir elevation manual reading		Weekly manually whenever LR is not in function	Twice daily
	LR	Water LEVEL RECORDER	Dam upstream face	(*)	(*)	reservoir elevation digital reading and registration		Daily	Twice daily
Pz	Ex	PIEZOMETER external to the dam body	downstream of the dam and of the reservoir	(*)	(*)	registration of deep aquifer and groundwater levels	they are fed by batteries, which functioning shall be periodically checked.	Daily automatically; monthly manual	Twice daily
	B	PIEZOMETER inside dam body (fixed) installation	Dam foundation	(*)	(*)	registration of water pressures at defined elevation below dam		Daily automatically; monthly manual	Twicedaily
DF (2) (4) (5)	V	V NOTCHES	inside dam galleries (and wherever applicable)	(*)	(*)	measures of amount of leakages through the dam and through the dam foundations. Measures of leakages through the rockmass around the Power Waterways.	The measurements shall be carried out and presented separately for drains attaining the dam upstream face (included dam joints drains) and drains crossing the dam foundations, in turn divided in bottom, right abutment and left abutment zones.. (4)	Monthly, or in any case every 10m of reservoir level raising.	Daily
	D	WATER LEVEL INDICATOR (data logger)	at pits in correspondence of dam galleries exit and in dam bottom gallery pump pits	(*)	(*)	measures of levels to quantify the amount of leakages through the dam and through the dam foundations	see above.	Daily	Every hour

Initials		Instruments Type	Position			Scope	Notes	Monitoring schedule (1)	
			Area	Ref. dwg	Elev.			routine	alert
					m a.s.l.				
L		WATER LEVEL GAUGE STAFF at galleries exits.	at pits in correspondence of dam galleries exits	(*)	(*)	measures of levels to quantify the amount of leakages through the dam and through the dam foundations	see above.	Monthly, or in any case every 10m of reservoir level raising.	Daily
	P	DRAIN FLOW measurement by means of PUMPS at bottom galleries pits	at dam galleries exit	(*)	(*)	measures of leakages through the dam and dam foundations recollected below tailrace water level	the operating criteria and conditions and alarm system for the dam drain pumping system is to be automatically implemented, to be integrated with pumps supplier operation manual. (4) (5)	Daily automatically or manually (with Staff) in case the automatic system is out of operation.	Twice daily
T	TC	THERMOCOUPLES	inside the dam body	(*)	(*)	registration of punctual temperature inside dam body.		Montly	Daily
	FO	FIBER OPTIC CABLES	inside the dam body	(*)	(*)	continuous registration of temperature inside dam body.		Monthly	Twice daily
DS (6)	Cl	COLLIMATORS	Internal: inside dam galleries alignments. External: alignments on dam crest and on d/s face	(*)	(*)	check of dam displacements (overall dam displacement or single block movements)		Monthly	Daily

Initials	Instruments Type	Position			Scope	Notes	Monitoring schedule (1)		
		Area	Ref. dwg	Elev.			routine	alert	
				m a.s.l.					
DS (6)	Fa Ma	FIXED AIM and MOBILE AIM	inside dam galleries and on dam crest	(*)	(*)	see above	to be used for displacements check together with collimator basements and mobile aims.	see above	Daily
	Jm	JOINT DEFORMOMETER automatic and manual types	inside dam galleries and on dam crest	(*)	(*)	check of joint movements		Daily	Daily
	PI	Inverted PENDULUM	On specific dam Instrumented Sections (IS)	(*)	(*)	Registration of relative displacement between dam and foundation.	Automatic readings by the Automatic Fixed Coordinometer	Daily automatic; monthly manual	Twice daily
	PD	Direct PENDULUM	On specific dam Instrumented Sections (IS)	(*)	(*)	registration of horizontal displacements at several elevations along the IS dam block.	Automatic readings by the Automatic Fixed Coordinometer	Daily automatic; monthly manual	Twice daily
E	EB	EXTENSOMETERS in boreholes	On specific dam Instrumented Sections (IS)	(*)	(*)	registration of foundation deformations in respect to the dam structure		Daily automatic	Daily
WL	MS	Meteo Station	(*)	(*)	(*)	Meteo data (temperature, wind, rain) records	Data need to be discharged from the instrument and elaborated on monthly basis.	Data discharge and elaboration on monthly basis	Weekly
	LR	Water levels Radar recorded	(*)	(*)	(*)	River level measurement		Data discharge and elaboration on monthly basis	Weekly

Initials		Instruments Type	Position			Scope	Notes	Monitoring schedule (1)	
			Area	Ref. dwg	Elev.			routine	alert
					m a.s.l.				
WL	LS	WATER LEVEL STAFF at Dam downstream face	Dam downstream face	(*)	(*)	River level of plunge pool	Measures to be correlated with radar levels and turbine outputs	Manually on daily basis.	Twice daily
	AC	Accelerographs	Dam, inside galleries at location to be defined (*)	(*)	(*)	Seismic movements	Measures to be considered and examined only in case of seism. Recorded automatically.	Continuously in automatic, until seismic event is recorded.	Continuously in case of seism

- (1) These are the frequencies of measuring activities.
- (2) Flow-meters, manometers, drain pipes extensions, other tools and adaptors are at hand at Dam control building, available for spot measurements where occasionally required on single drains or piezometers holes registering important leaks.
- (3) For DS instruments all reading devices equipment shall be at hand at Dam control building.
- (4) Flow measurement of individual drains that are discharging important leaks shall be monitored with same criteria of the general monitoring of drainage system of the Dam.
- (5) Drains recollecting warm water springs in foundations, if any, shall be possibly identified and monitored as separate datum also.
- (6) Reading devices equipment shall remain at hand at Dam control building.
- (*) To be filled at detailed design and construction stage.

Table 1 - SUMMARY TABLE of Instruments CONTROL PLAN

B.2.3 INSTRUMENTS MEASUREMENTS REPORTING

The measuring activity (that can be commenced during the impounding period) shall continue during the period of operation of the plant.

All data gathered shall be always available on site. A REPORT presenting all data gathered by the instruments shall be prepared on MONTHLY basis.

Several data of instruments installed in the dam body can be extracted from the synoptic panel of the Acquisition Unit that is assumed will be provided to gather all data at Dam Control Building, without need to inspect the single instruments unless for specific punctual verifications. The Acquisition Unit is assumed provided with dedicated software that allow selection and extraction of data in tabular and graphical format and combination of readings of different instruments at same time.

The report shall include and organize the data and information described for each type of measurements. The data required to be presented are listed along this chapter for each type of instrument, to be provided in tabular and graph format.

Typical graphical representations shall be provided during monitoring for the most relevant type of records, where necessary combined with or referred to the reservoir water levels, plant operation data or rain data, and also referred to relevant design reference graphs when available (for instance for dam uplift), to allow a prompt evaluation of the results, and consequently definition of actions to be taken if required.

The following indicative list of data to be presented is provided for reference:

- 1) TEMPERATURE
 - a. Thermocouple: reading & charts
 - b. Optic Fiber: reading & charts
- 2) DRAIN FLOW
 - a. Piezometer inside Dam body: reading & charts
 - b. Piezometer outside Dam body: reading & charts
 - c. Dam Instrumented Sections: Piezometers Water level
 - d. Drain: water flow monitoring
 - e. V-notch: water flow monitoring
- 3) LEVEL
 - a. River, impounding and RCC levels: reading & charts
 - b. Plunge Pool water level readings
- 4) STRESS
 - a. Multi-Points Extensometers: reading & charts
 - b. Single-Point Extensometers: reading & charts

- c. Mechanical Strain Gauges: reading & charts
- 5) DISPLACEMENT
 - a. Inverted Pendulum: reading & charts
 - b. Direct Pendulum: reading & charts
 - c. Dam absolute movements: from inverted and direct pendula data elaboration
 - d. Joint Deformometer (3D tern manual): reading & charts
 - e. Joint Deformometer (3D tern automatic): reading & charts
 - f. Collimator alignment: reading & charts
- 6) VARIOUS
 - a. Weather report: meteo station data & charts
 - b. Rainfall historical sequences: reading & charts

The report in ROUTINE or ALERT conditions (see par. 1B.3.2 CRITERIA FOR ROUTINE OR ALERT PROCEDURE APPLICATION also next chapter) shall be forwarded MONTHLY to the contacts reported in a table constructed as follows:

Plant Management Structure				
Name	Position	Telephone	E-mail	Mail address

Table 2 - Typical table of Contacts for Routine or Alert procedure implementation

For both conditions this task is a responsibility to be assigned to the manager of the PMS.

In case of need to trigger an ALARM condition, or in case of need to implement the CONTINGENCY PLAN, described in Part E of the Dam Safety Plan, the contacts reported in par. E.7.4 of the Dam Safety Plan shall be immediately contacted.

The table above as well as the tables reported in par. E.7.4 of the Dam Safety Plan shall be filled by all the parties within the Owner organization involved in the Plant operation.

B.2.4 METEO and RIVER LEVELS MEASUREMENTS

The Meteo station is foreseen to be installed near dam and shall continue to record the meteo data (rain, wind, temperatures) from the automatic acquisition unit on monthly basis, for correlation with other measurements, and finally presented in a yearly report (possibly without interruption since the construction period).

Readings of river levels downstream of the dam shall be plotted on the river rating curve to obtain flow data. This rating curve shall be updated (during the construction and impounding period, as well during the operation period) by calibration with direct measures of flow in both dry and wet season conditions.

Levels records (in automatic downstream of river diversion) shall be taken on daily basis.

Levels and flow data shall be gathered and presented in a monthly report, correlated to the Power House, Spillway, Middle Outlets and Ecological discharge valves outflows (as far as it is the case).

B.2.5 RESERVOIR WATER LEVEL MEASUREMENTS

The reservoir water levels measurements shall be carried out by means of automatic (Level indicators) and manual (graduated level staffs) instruments.

During the operation of the plant the automatic level indicators will record water levels in the reservoir, and will transmit the data to the acquisition unit system, that is supposed to be present to gather the results at Dam Control Building. Whenever the automatic acquisition does not work, manual and visual readings of the reservoir water levels on the staffs that are installed along the dam upstream face shall be carried out.

The levels records shall be available immediately on site for all the purposes requiring decisions or actions linked to the reservoir water levels.

The plot of the river levels shall be always included in the monthly reports associated to all the other instruments measurements, for correlation purposes.

B.2.6 OUTFLOWS AT POWER HOUSES

This applies for each Power House.

The Power House Outflows are automatically continuously measured on each unit outlet and results gathered at Power House control building.

This measurement is firstly used in automatic by the control system of the plant for the energy production and for the management of each of the unit.

The daily records of the overall flow discharged at Power House shall be also gathered and reported in the monthly report of the instruments monitoring for comparison (also with tailwater levels) and overall understanding purpose.

Together with this datum, whenever the Middle Outlets and/or Spillway is in function, the relevant outflow, derived by the use of the reservoir level measurements (see previous paragraph) and by the relevant rating curves, shall be also provided in the monthly report of the instruments monitoring.

B.2.7 WATERS MONITORING: SPRINGS

The existing natural springs, if any, are required to be identified by:

- position
- water flow
- water temperature

A regular record (possibly on monthly basis) of water flow for the springs shall be carried out. Data shall be presented correlated to the river and reservoir levels and to the rain records, as measured in the closest available meteo-station.

The data shall be presented in graph and tabular format in the monthly report.

B.2.8 WATERS MONITORING: DAM PIEZOMETERS

A) PIEZOMETERS INSIDE THE DAM BODY

The piezometers inside the dam body are to be monitored automatically by the Acquisition Unit that is supposed to be present to convey the data at Dam Control Building.

Measures of pressures (water levels) at each piezometer shall be done daily in automatic and manually on monthly basis. This frequency can be modified in occasion of important rain events, rapid raising/lowering of the reservoir, as well as in case of seism.

Measures of drain discharge shall be plotted versus the time on monthly basis, and presented in the monthly report, correlated for comparison purposes with other following outputs:

- foundation drains flow;
- dam drains flow;
- river levels;
- dam piezometers readings;
- readings of other piezometers located in the Batoka site area (see next paragraphs);
- rain records at the meteo-station;

- reservoir levels.

The data shall be presented as far as possible grouped along different alignments with water levels plotted on transversal and longitudinal dam vertical sections to visualize correlations and trends along the dam foundation. Measurements from external piezometers (see next paragraph) aligned along these sections shall be also shown on the same drawing.

B) PIEZOMETERS OUTSIDE THE DAM BODY

The water table in the flanks of the river valley below the maximum reservoir level downstream of the dam shall be monitored also by means of external piezometers, whose number and position will be defined during detailed design and construction stage and reported in a table constructed as follows:

No	ID	Length	Easting	Northing	Elevation	Type	Position
		m	m	m	m.a.s.l.		
1							
2							
...							

Table 3 - Typical table with positions of piezometers

The monitoring shall be regular (daily measurement in automatic, on monthly basis manually) and shall cover dry and wet season period.

Every month the measurements shall be collected by means of portable reading units and provided in graphical and tabular format, together with all the other information pertinent to the meteorological conditions and dam as indicated in the previous paragraph.

B.2.9 DAM DRAIN MONITORING

Monitoring of dam galleries conditions and relevant drainage system is very important to be carried out during the plant operation period.

The amount of water coming out from the Dam drain gallery shall be monitored by means of the water level sensors (divers) and V-Notches purposely foreseen.

The overall amount of water discharged at each gallery level shall be also measured at each gallery exit, where automatic (with diver in a dedicated pit) and manual (with V-notch, meter, or pit of known volume) measurements can be made.

For the galleries under tailrace level the same measure shall be taken recording the water levels in the pit and the pumps operation records.

Samples of the drain water, flowing out of the drainage pipes crossing the dam foundation, must be also taken in order to check the turbidity.

Frequency of turbidity test will be revised on the basis of flow measurements. At any significant increase of seepage, it will correspond an increase of test frequency.

The measurements shall be carried out and presented separately for drains attaining to the dam upstream face (see also prescriptions of next paragraph), the dam joints drains, and drains crossing the dam foundations, in turn divided in bottom, right abutment and left abutment zones.

Calibration of V-notch will be checked by means of a graduated bucket and a stopwatch.

In case of necessity (when there is evidence of significant or anomalous outflow from a single drain), measurements of single drains outflow can be carried out manually with a bucket after installing a bent pipe extending the drain pipe, as foreseen in design documents.

Adaptors, pipes extensions, flow-meters and manometers shall be available at Dam control building store to be used for spot measurements on single drains when needed.

The following additional aspects shall be considered in organizing such activity:

1. Consideration should be given to monitoring the depth and type of sediment at the gallery weirs before cleaning each gutter, rather than just removing and discarding it. This shall be done on monthly basis.

Samples of the sediment should be analysed on occasion for grain size, plasticity, pH, and composition. This information can be very useful if any piping or erosion starts in any of the foundation drains. The pH can be used to indicate if some of the seepage is coming from internal drainage of the dam itself, picking up calcium hydroxide (basic) on the way. Consideration should also be given to using a hand held "pistol" type temperature indicator to check the temperature of water coming from foundation drains. Rather than rely only in keeping complex records that are not always readily available, a simple method of documentation can be also used to just write the date and temperature on the wall next to the drain with a pencil. If the temperature changes, the date and new temperature should be noted

2. Consideration should be given to recording the volume of water pumped per week or month from the gallery sumps. Seepage flows shall be measured using weirs in the gallery gutters, but the pump records can also be used as a check. Also, it is possible on very high dams to observe a

sudden increase in gallery flows sometime during the life of the structure due to a failed waterstop, a sudden crack, or a significant change in foundation seepage, that could flood the gallery gutter and weirs. In this case, checking the pumping records (time and capacity, or by a flow meter) can provide an idea of the amount of flow.

Monitoring of dam galleries drainage system shall be carried out monthly in routine conditions, as far as the manual readings are concerned.

Water levels indicators (data loggers) shall be recorded in continuous the levels in the pits at the exit of the galleries, and send the records to the control center.

The pumps pits can be equipped with a system of recording and progressive starting of pumps (details to be defined with the supplier)

All the records shall be presented on a monthly report.

Data shall be presented correlated to the impounding levels and with the rain records as measured in the meteo-station.

Graphs of following outputs (related to water measurements) shall be provided in the same plot, for comparison purposes:

- Foundation drains
- Dam drains
- Reservoir levels
- Springs drains
- Dam piezometers
- Readings of other piezometers located in the site area
- Rain records at the meteo station.
- Power Houses operation (turbines in function, discharged flow).

B.2.10 THERMOCOUPLES

At feasibility design stage, thermocouples are foreseen to be installed in the dam.

The output of the thermocouples installed during the dam construction shall be acquired (as far as possible) on monthly basis.

The results shall be plotted versus time on monthly basis, with indication of the location and RCC zoning characteristics at that location (placing temperature and time, cement content, etc.).

The results shall be compared with the expected trend of temperatures in the dam body as defined in the next chapter.

B.2.11 FIBER OPTIC CABLES

At feasibility design stage, fiber optic cables are foreseen to be installed in the dam. The prescriptions for the fiber optic sensors readings are recalled hereinafter.

The output of the installed fiber optic cable sensors (FBG) shall automatically acquired in routine conditions on monthly basis.

The results shall be plotted versus time on monthly basis, with indication of the RCC characteristics (placing temperature and time, cement content, etc.).

Graphs of thermocouples and fiber optic sensors output shall be provided in the same plot, for comparison purposes, and compared with the expected trend of temperatures in the dam body defined in the next chapter.

B.2.12 EXTERNAL BENCHMARKS

External benchmarks are foreseen to be available around the dam site. They will be used during construction and they are not object of systematic monitoring during the operation period, however the Operator shall know their existence for any willingness of re-calibrating at large scale existing monitoring system basepoints (for instance after a seism, if it is deemed necessary to re-check the position of the collimators basepoints on the dam abutments, or the one on the dam crest, in respect to points more distant from the dam structure). The position of available external benchmarks shall be provided in a dedicated drawing before plant enters in operation.

B.2.13 COLLIMATORS WITH FIXED AND MOBILE AIM

Fixed and mobile aims with collimator are foreseen to be installed in the dam.

Measurements shall be carried out manually by means of an optical collimator and fix and mobile aims by a skilled surveyor, registering horizontal and vertical displacement on each aims alignment and for each aim (typically one for each dam block).

Measurements shall be done for routine conditions on monthly basis, or in case of sudden important change of levels occurred in the reservoir.

Records shall be presented on a monthly report, recorded and plotted on the longitudinal section where they are measured and on the cross sections of the Dam, together with the reservoir water levels and the following instruments measures (described in the next paragraphs):

- External Targets displacements
- Invert and direct pendula
- Extensometers
- Joint deformometers

The measurements must be always reported separately for each settlement-measuring device.

The results shall be assessed as described in the next chapter.

B.2.14 JOINT DEFORMOMETERS

Joint deformometers are foreseen to be installed inside the inspection and drainage galleries of the dam.

Joints deformometers automatic readings shall be carried out, registering horizontal and vertical displacement on each joint, with the Acquisition Unit, and manually with Portable reading units whenever a defect or interruption or anomalous trend is observed in the automatic readings.

Measurements shall be done on monthly basis, or in any case every 10m of sudden reservoir level raising.

Results shall be provided in a monthly report, organized and presented as done for the external targets and collimators displacements (see previous paragraphs).

B.2.15 PENDULA

The INVERT pendula are foreseen to be installed with the head mounted in the galleries above tailrace water level.

The DIRECT pendula will be installed in the dedicated shafts.

All pendulum measurement record is foreseen to be daily and automatic.

A monthly basis check by manual reading is by default required.

Measurements shall be recollected on monthly basis, recorded and plotted versus the time.

Records shall be provided, together with other displacements and deformation measures, plotted along the dam sections pertinent to the pendula, for an immediate comparison with the expected values of settlements (see next chapter).

B.2.16 EXTENSOMETERS

Extensometers are foreseen to be installed in the dam.

Extensometers automatic readings shall be carried out with the Acquisition Unit, and manually with Portable reading units whenever a defect or interruption or anomalous trend is observed in the automatic readings.

Measurements of extensometers shall be recollected on monthly basis (default automatic readings).

Results shall be provided in a monthly report, recorded and plotted versus the time with indication of the reservoir water levels, correlated to the other displacement measures (data available from external targets, collimators, pendula) for an immediate check, as described in the next chapter.

B.2.17 ACCELEROGRAPHS

Strong motion measurement record is continuous and automatic in case of seismic event. The Acquisition Unit is typically set to also register such measurements.

Measurements, whenever acquired by the instrument, shall be recorded and plotted versus the time and presented together with the other dam instrumentation measurements.

Any exceptional or anomalous record shall be transmitted as soon as possible to the National Authorities deputed to the seismic events monitoring of the region, and they shall be made available for comparison, for study and evaluation purpose, with the accelerographs of the seismic cases used for the dam stability verifications.

In case of seismic event, further specific measures for structural control of specific parts of the works will be decided on case by case basis.

B.2.18 DOWNSTREAM WORKS INSPECTION

The inspection of the works and the downstream areas aim to find and measures any signal of potential leakage or static problems to the structures connected with the operation of the Plant.

A careful visual inspection of the works should be carried out with particular attention to the hydraulic steel structures when they operate and Dam upstream zone (as far as possible to inspect it from upstream and from the galleries).

The inspection of the works (object, methodology, frequency, timing and reporting requirements) is described in more detail in Part D of the Dam Safety Plan, dedicated to the Plant maintenance, to which reference shall be made.

B.3 DAM MONITORING RESULTS ELABORATION: ROUTINE AND ALERT CONDITIONS

B.3.1 INTRODUCTION

This chapter:

- illustrates the principles of how to evaluate and assess the results of the measurements carried out with the instruments,
- consequently individuate the conditions to implement the procedures associated to the ROUTINE or ALERT and, in case, to the DRAWDOWN conditions.
- Describes the ROUTINE, ALERT, CONTROLLED DRAWDOWN and EMERGENCY DRAWDOWN procedures.

During the normal operation of the plant, within the PMS, an instrumentation monitoring reporting shall be organized and continued as done in first impounding period.

For some kind of measurements, there is not a fixed *a priori* specific threshold that marks the passage from routine to alert condition. In any case it is necessary to define or adjust threshold values after first (and subsequent) period of impounding and operation according to the first (and subsequent) measures, as well as the first assessment of the dam behavior and of any anomalous record of any instruments carried out during the first impounding period.

A general criterion for the application of the Routine or Alert procedure is in any case generally fixed as follows:

- When the reservoir level is stable (not raising or lowering), the alert procedure is activated if there is a trend of increasing with time of the datum recorded.
- When the reservoir level is raising or lowering, the alert procedure is activated if there is a trend of increasing of the datum recorded that is time dependant and not level dependant.

The assessment is focused and organized in this chapter on the following main aspects dealing with the dam stability and safety:

1. UPLIFT PRESSURES ON DAM FOUNDATIONS
2. GROUNDWATER CIRCULATION
3. LEAKAGES
4. DAM FOUNDATION SETTLEMENTS and DAM DISPLACEMENTS
5. DAM THERMAL CONDITIONS

The table at par. B.3.2 CRITERIA FOR ROUTINE OR ALERT PROCEDURE APPLICATION summarises the criterion of Routine or Alert procedure application. It shall be updated and detailed during detailed design and construction and first impounding phases.

B.3.2 CRITERIA FOR ROUTINE OR ALERT PROCEDURE APPLICATION

In order to evaluate the Dam behavior the criteria stated in the following tables shall be followed, for the most important parameters to be controlled, namely:

1. Dam **uplift pressures** and groundwater
2. Dam and Power Waterways **leakages**

Other parameters that shall be controlled are:

3. Dam foundation settlements
4. Dam displacements
5. Dam RCC temperatures

Such parameters will be controlled by means of some of the instruments available, as described in previous chapter 1 "

DAM INSTRUMENTATION OPERATION AND MONITORING", and assessed as described in this chapter.

The most critical parameters are the ones at points 1 and 2 above, that shall be firstly checked in respect of possible triggering of alert procedures.

Records of instruments devoted to the control of the other parameters will be collected systematically, but used only whenever necessary to analyze the possible causes and effects in case an unforeseen event or anomalous trend is found.

In the following tables, the threshold and acceptable limits, where indicated, are the ones defined in the subsequent paragraphs of this chapter.

STABLE WATER LEVEL IN THE RESERVOIR		
	<u>Routine Procedure (1)</u>	<u>Alert Procedure (2)</u>
UPLIFT PRESSURES ON DAM FOUNDATIONS	Within the threshold limit defined in the detailed design of the dam (see par. B.3.3 below). Stable	Exceeding threshold limit defined in the detailed design of the dam (see par. B.3.3 below). Increasing with time, independently from season trend.
GROUNDWATER	Stable or following season trend.	Increasing with time, independently from season trend.
LEAKAGES THROUGH DAM FOUNDATIONS, DAM BODY, POWER TUNNELS	Stable or (for foundation drains) variable according to rain/dry season trends.	Increasing with time (for foundation drains only if independently from season trend). For local drains when jetting continuously.
DAM FOUNDATION SETTLEMENTS	Stable.	Increasing with time.
DAM DISPLACEMENTS	Stable.	Increasing with time.
RCC DAM TEMPERATURES	Within acceptable limits fixed by the detailed design of the dam	Increasing above acceptable limits fixed by the detailed design of the dam

Table 4 - Criteria for Routine or Alert procedure application – case of stable reservoir water level

CONTROLLED RISING OF WATER LEVEL IN THE RESERVOIR		
	<u>Routine Procedure (1)</u>	<u>Alert Procedure (2)</u>
UPLIFT PRESSURES ON DAM FOUNDATIONS	Level dependant increasing with ratio <1. In any case within the threshold limit defined in the detailed design of the dam (see par. B.3.3 below).	Time dependant increasing. Above the threshold limit defined in the detailed design of the dam (see par. B.3.3 below).
GROUNDWATER	Level dependant increasing	Time dependant increasing.
LEAKAGES THROUGH DAM FOUNDATIONS, DAM BODY, POWER TUNNELS	Level and (for foundation drains) season dependant increasing	Time dependant increasing. For local drains when jetting continuously.
DAM FOUNDATION SETTLEMENTS	Level dependant increasing.	Time dependant increasing.
DAM DISPLACEMENTS	Level dependant increasing.	Time dependant increasing.
RCC DAM TEMPERATURES	Within acceptable limits fixed by the detailed design of the dam	Increasing above acceptable limits fixed by the detailed design of the dam

- (1) for the application of the ROUTINE PROCEDURE all conditions stated in the table shall be verified;
(2) the ALERT PROCEDURE will be activated as soon as one of the conditions will be verified, or the Reservoir water level is higher than maximum operating level.

Table 5 - Criteria for Routine or Alert procedure application – case of raising reservoir water level

If above the Spillway sill level uncontrolled reservoir filling occurs due to an exceptional flood event that do not allows to maintain the water level in the reservoir within the maximum operating level:

- alert procedure will be firstly activated;
- then the procedure "OPERATION CRITERIA IN CASE OF EXCEPTIONAL HIGH FLOODS (RESERVOIR ROUTING) described in Part E of the Dam Safety Plan will be implemented;
- then, as far as necessary, the Emergency drawdown procedure described in this and in Part E of the Dam Safety Plan can be activated.

If according to the results of observations carried out during the Alert Procedure, an emergency state is triggered, the Controlled Drawdown Procedure or the Emergency Drawdown Procedure will be activated, as described in last paragraphs of this section.

B.3.3 UPLIFT PRESSURES ON DAM FOUNDATIONS

The levels registered in the piezometers inside the dam body intercepting the dam foundations, correlated with the upstream and downstream water levels reached during the impounding, shall be compared with the value of uplift pressure assumed in the dam stability calculations at the position and depth of the piezometer itself, scaled in proportion to the reservoir water level.

In principle, wherever the observed levels in the piezometers exceed the values assumed in the design, the ALERT procedure shall be activated, unless for minor deviations or local anomalies that can be imputed to local geological features or specific reasons, that can be evaluated on case by case basis.

In sake of simplicity for an easy first appraisal of the phenomenon the comparison can be made on the instrumented sections, in respect to the assumptions made on design uplift water levels for the Normal Operating Conditions in the Dam stability analysis that will be developed during the detailed design, from which the following figure represent a typical example.

Uplift pressures considered varying from the hydrostatic pressure relative to US Army Corps of Engineers, "Gravity dam design", EM 1110-2-2200, 1995:

- *at u/s toe* $H1 = \text{the reservoir water level}$
- *at d/s toe* $H2 = \text{tailwater level}$
- *at drainages* $H3 = 0.33 \times (H1 - H2) \times (L - X) / L + H2$

as illustrated in the following figure:

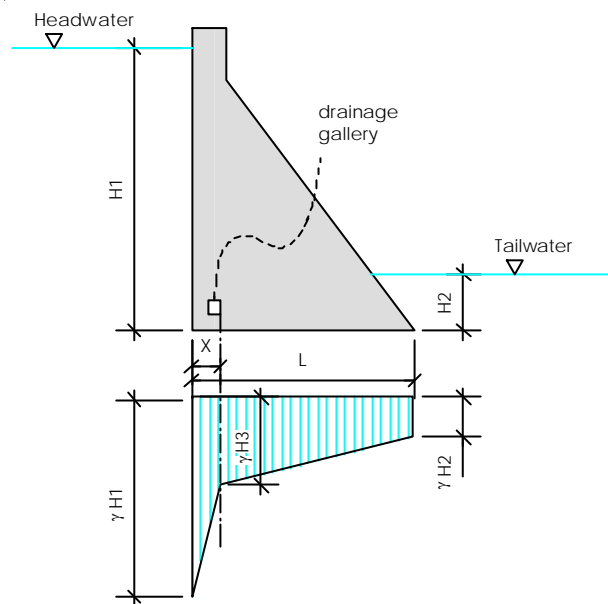

$L =$ dam base length

$X =$ drain distance from u/s toe

$H2 =$ tailwater depth

The readings of the piezometers shall be plotted and compared with the uplift design reference line (in the figure above shown in blue, as example) This kind of outputs shall be provided for all instrumented sections, to easily individuate any anomalous value exceeding the assumptions made in the dam design.

It's also important to observe the pressure increase versus reservoir level for the various piezometers; data shall be presented showing the water level in the piezometers installed at different galleries versus the time and the reservoir water level. If deemed necessary, correlation curves (H piezometers versus reservoir water level) may be drawn.

It is recommended that before operating the plant the present document be integrated with a table in which for each piezometer there are provided the following values of total head (expressed in meters above sea level) used for the purpose of calibration of the instruments:

1. ALERT TRESHOLD

This is the value above which the monitoring of the piezometer shall pass from ROUTINE to ALERT conditions (see next dedicated paragraphs)

2. ALARM TRESHOLD

This is the value above which an alarm shall be activated, being the head reaching about 90% of the value assumed in the design for the stability of the dam.

Of course in such case an analysis and check shall be made on the specific piezometer also in relation to the trends of other and adjacent piezometers.

Piezometers can be dependent from reservoir water elevation. For this reason the above threshold values shall not be univocally defined, but instead given as function of reservoir water level (H).

The software of the instruments acquisition unit can be already programmed to have inserted the following values, as function of H, for the automatic monitoring of the piezometers levels.

PIEZOMETERS typical threshold values		
Piezometer ID	1= ALERT TRESHOLD	2=ALARM TRESHOLD
-	m a.s.l.	m a.s.l.
1	$> z1 + k1 * (H - z1)$	$> z1 + k1' * (H - z1)$
2	$> z2 + k2 * (H - z2)$	$> z2 + k2' * (H - z2)$

Table 6 – Piezometers typical threshold values

B.3.4 GROUNDWATER CIRCULATION

The monitoring activities of the groundwater is aimed at detecting potential anomalous or local unexpected trend of pressure or water flows increasing in connection to the progress of impounding or reservoir fluctuations.

The analysis will be made through the combined assessment of measurements of external waters (rain, river flows, springs) and the deep piezometers available. A table like the following shall be prepared with all the available piezometers listed, and the ones possibly intercepting any aquifer highlighted.

Piezometer	location	Top elevation	Bottom elevation	Notes
1
...

Table 7 – Typical list of piezometers

Typical outputs of the monitoring to be provided are plots of deep aquifer piezometers level versus time and versus impounding water level, allowing to check the criteria for routine or alert procedure application.

Anomalous records of leakages from the drains, among the ones listed in the table above, intercepting the dam foundation in correspondence of possible special or weak zones, shall be linked and correlated to the above observations.

All the above is mainly related to the dam structure, but at the same time useful information about the groundwater circulation and its dependence from the reservoir water level shall be acquired by the measurements available from the available drainage system/ other external drainages on all the Batoka site.

A table analogue to the one envisaged for the Dam piezometers shall be prepared, in which for each piezometer there are provided the following values of total head (expressed in meters above sea level) used for the purpose of calibration of the instruments:

1. ALERT TRESHOLD

This is the value above which the monitoring of the piezometer shall pass from ROUTINE to ALERT conditions.

2. ALARM TRESHOLD

This is the value above which an alarm shall be activated, in the case the deep piezometers level gets close to the limit compatible with the dam or other structure stability (according to the detailed design assumptions).

Of course in such case an analysis and check shall be made on the specific piezometer also in relation to the trends of other and adjacent piezometers and on the reservoir.

Also these piezometers can be dependent from reservoir water elevation. For this reason the above threshold values are not univocally defined, but shall instead be given as function of reservoir water level (H).

Also in this case, the software of the instruments acquisition unit can be already programmed to have inserted the following values, as function of H, for the automatic monitoring of the piezometers levels.

As far as groundwater circulations (deep aquifers) no direct measures of the total seepage flow are supposed to be available and the influence of the groundwater, the surface water flow, of the precipitation and of the impounding process or reservoir fluctuations on the seepage flow is quantitatively unpredictable, making definition of sharp seepage threshold values unreliable.

As far as the flow is concerned, indicatively, the total amount of recollected water from these drains should remain in the range of some liters per second which, in terms of volume, cannot be considered critical at the scale of the project.

The temperature of the drained water shall be measured, to gain information about its origin.

B.3.5 LEAKAGES

LEAKAGE (SEEPAGE) THROUGH DAM FOUNDATIONS

The measurements gathered from the drains crossing the dam foundations will be analyzed considering the sum of contribution of all the drains crossing the dam between two subsequent galleries, and where necessary correlated to specific ground or foundation features or local weak zones.

As far as possible the total flow value sum of contribution of all the drains catching possible springs on dam foundation shall be recorded and assessed separately from other drains or water outputs.

Indicative threshold value of leakage through dam foundations will be provided after observations relevant to the first year of impounding and the specificity of the dam foundations, the flows will be monitored and any anomaly at local scale of a single drain as well as distributed or total leakage flows will be recorded and assessed. As far as the impounding and plant operation go on and further data and information are gathered and interpreted, leakage flow alert threshold values will be updated or refined, if necessary.

In any case, the monitoring of the leakage trends (that in normal conditions shall follow the reservoir level trends and generally be stable in absence of variation of the reservoir levels) is much more important than the absolute value of recorded leaks.

Whenever water is clearly flowing (and not dripping or oozing) from a specific drain or point, such drain shall be object of monitoring with alert procedure.

LEAKAGE THROUGH THE RCC DAM

Any water incoming in the dam body from RCC dam drains or from vertical joints drains shall be object of local monitoring.

Whenever water is clearly flowing (and not dripping or oozing) from a specific drain or point, such drain shall be object of monitoring with alert procedure.

As far as the overall flow measured at the exit of the drain galleries, threshold values can be established if needed during the operation of the plant, taking into account the monitoring results of the prior phases and on their interpretation.

The extreme limit threshold value of the total flow recollected at lowest gallery can be limited to the overall capacity of the pumps that will be installed (this applies also for the flow coming from drains crossing the foundations). The pumps in the pits will be set with a progressive water level based functioning and alarm system. If the maximum capacity flow is exceeded the contingency plan shall be triggered.

Typical outputs of leaks monitoring relevant to both leakages through foundations and through RCC dam are graphs reporting the amount of leaks versus the time, presenting the distinct contributions of V-notches and single drains and their location and type, allowing an immediate understanding of the correlation with the reservoir fluctuations and detection of possible local or generalized anomalous trends.

Additionally tabular outputs shall be also gathered with indication of water temperature, where measured (especially in drains through foundation).

B.3.6 FOUNDATION SETTLEMENTS and DAM DISPLACEMENTS

The dam foundation settlements, measured with the extensometers foreseen to be installed in boreholes and with the collimators along the dam downstream face, are assumed will be compared with the expected deformations resulting from the dam stability analysis at design level for the typical (calculation) sections and for different reservoir levels.

The comparison will be conducted using the nearest calculated section available, considering the scenario closest to the reservoir level at the moment of the measurement.

The assessment will be conducted considering, with engineering judgment, all possible causes of any movement recorded, and the levels of the impounding and of the dam at the moment of the measurements.

The same approach is foreseen for the dam overall displacements measured with direct and invert pendula and the relative displacements of dam single blocks or vertical joints measured by direct pendula or by collimators located on dam downstream face, that will be compared with the expected displacements resulting from the dam stability analysis carried out in the detailed design phase.

As a general indication, displacements and movements of few millimeters are considered negligible at the scale of the project and in consideration of the accuracy of the instrumentation used.

Typical outputs of the monitoring present displacements continuously plotted versus the time (in both upstream to downstream direction and left to right direction) and the same for pendula readings, together with reservoir elevations, allowing their interpretation and correlation.

Whenever significant anomaly, abrupt isolated displacements or a trend not following the rate of reservoir level fluctuations (ref. table at par. B.3.2 CRITERIA FOR ROUTINE OR ALERT PROCEDURE APPLICATION) and substantially not consistent with the assumptions made in the design will be detected, the alert procedure will be activated, and possible actions decided on case by case basis.

B.3.7 DAM THERMAL CONDITIONS

The readings of the thermal records provided by the thermocouples and fiber optic sensors in the dam body during the impounding shall be compared with the value of maximum temperatures assumed in the dam design thermal analysis to be carried out at detailed design stage at the position of the measurement.

To this purpose specific plots for temperature readings comparison are to be provided, for main sections and most representative scenario analyzed in the detailed design.

Data extracted in tabular format from manual or automatic readings of both thermocouples and fiber optic sensors can be used to make such check. At the same time contours of temperatures can be plotted in significant sections and compared with the temperature field assumed for design calculations, to detect possible macro zones of possible temperature deviation.

Whenever the observed temperatures reach values out of the designed range expectation, the ALERT procedure shall be activated.

B.3.8 ROUTINE PROCEDURE

During Routine procedure, instruments reading and reporting activities, are executed as described in this report (see in particular *Table 1* of par. B.2.2).

B.3.9 ALERT PROCEDURE

Instruments readings are incremented as follow:

- Daily readings will be carried out not less than twice per day (also during night time);
- Other readings will be carried out not less than daily.

More details are provided in see in particular *Table 1* of par. B.2.2.

The data, only pertinent to the instruments readings falling in the alert conditions, shall be promptly organized in reports for engineering evaluation.

If deemed necessary, according to the analysis of the results of observations carried out during the Alert Procedure, the Controlled Drawdown Procedure or the Emergency Drawdown Procedure will be activated.

B.3.10 CONTROLLED DRAWDOWN PROCEDURE

The Controlled Drawdown Procedure (CDP) is finalized to lowering the reservoir level without causing damages to the outlet structures such as Spillway, Power Waterways and Middle Outlets.

If according to the results of observations carried out during the Alert Procedure, an emergency state is triggered but any impending hazard is excluded, the Controlled Drawdown Procedure will be activated to perform inspections and repair works on the submerged structures as necessary and as far as possible (no dewatering is physically possible below the Middle Level Outlet minimum operating level).

This is valid only for a limited range of reservoir water levels and within the limits of capacity of the available discharging devices versus the incoming flows (therefore also depending on the season and on the duration of the emergency state).

In case it is required, for instance in order to inspect lower portions of dam upstream face or the portals of Power Tunnels, or for decisions consequent to the results of the instrumentation monitoring, to operate a reservoir drawdown aimed to maintain as much as possible the water level to the minimum possible level, the CONTROLLED DRAWDOWN PROCEDURE will be carried out in accordance to the instructions of the Contingency Plan provided in the Part E (Emergency Preparedness Plan) of the Dam Safety Plan.

It is to be noted that in exceptional conditions the Middle Outlets can be temporary work up to a exceptional minimum elevation, but it is to be reminded that maintenance operation in dry conditions in the reservoir and dam areas below this elevations are not physically possible.

B.3.11 EMERGENCY DRAWDOWN PROCEDURE

If the results of observations highlight an impending hazard for the dam safety, the Emergency Drawdown Procedure will be carried out in accordance to the instructions of the Contingency Plan described in the Part E (Emergency Preparedness Plan) of the Dam Safety Plan.

PART C - OPERATIONAL PLAN (Preliminary Plan)

C.1 INTRODUCTION

C.1.1 CONTENT AND STRUCTURE OF THIS PART

This is the **PART C "OPERATION PLAN (Preliminary Plan)"** of the Batoka Dam Safety Plan.

This part of the document, and its references, provides the feasibility design guidelines for the operation of the Batoka scheme, including the dam, power waterways, power house and other appurtenant structures.

It outlines the operation activities and procedures relevant to the Batoka Dam and Hydro Power Plants, to be detailed and implemented by the Project Management Structure that will be appointed by the Owner(s) of the Plant.

Being the design at Feasibility stage, this document has a Preliminary nature, being necessary to be developed and detailed during project implementation. The final plan is due prior to 6 months before initial filling of the reservoir according to the development and detail of the design, and further on according to the construction of the plant itself.

According to the structures of Ownership and Operation that Zambian and Zimbabwean countries and ZRA will put in place, the responsibility of operation of the dam and of the two plants can be assigned to different PMSs, that, in the frame of development of the manuals and of relevant implementation rules and structures, will organize (dividing and coordinating as appropriate) the work to be done and the limits and coordination of responsibilities. At the present stage of the design, and considering the importance to have an overall view of the Batoka scheme operation requirements, the document is developed as one manual for the whole scheme.

As far as the Batoka Plant OPERATION instructions are concerned, this part includes:

- The description and instructions for the OPERATION of the plant in normal condition of power production
- The instructions for the proper and safe operation of the hydraulic device and the use of the civil works.
- Other specific prescriptions for the use of civil works.

The instruction for measurements to be collected by the instruments available at Batoka, and for their presentation, use and assessment, are provided in Part B of the Dam Safety Plan.

This part of the report is divided in the following chapters:

- 1) INTRODUCTION

Describes the content of the report and its structure.

2) ROLES and RESPONSABILITY

Outlines the general frame of roles and responsibilities for the Batoka HEP operation and maintenance activities.

3) SYNTHESIS OF RESERVOIR AND PLANT OPERATING CONDITIONS

In this chapter is provided a synthetic description of:

- the plant operating rules and conditions,
- the reservoir operating conditions,
- the system of power supply feeding the Plant.

4) PLANT HYDRAULIC CONTROL DEVICES OPERATION

In this chapter it is provided a description, for ordinary and exceptional cases of operation, of the opening and closure manoeuvres for each hydraulic control equipment (valves, gates, bulkheads, stoplogs) for all the hydraulic devices (Middle Outlets, Spillway, Power Waterways, Draft Tubes, etc.) of the Plant.

The prescriptions for the environmental flows release are also reported, associated to the specific hydraulic devices devoted to the environmental releases.

5) HYDRAULIC CONTROL DEVICES RATING CURVES

In this chapter it is mentioned that it will be provided a description of the hydraulic rating curve of each of the hydraulic devices of the Plant, including the reservoir rating curve.

6) OTHER PRESCRIPTIONS FOR CIVIL WORKS OPERATION

In this chapter some specific prescriptions for the use of specific civil works at Batoka Plant are provided.

7) INSTRUCTIONS FOR PLANT OPERATORS FIRST TRAINING

In this chapter there are guidelines and indications for the Operators, as well as a format for the spare parts check.

Drawings illustrating all the works are the ones of the Feasibility Design, separately issued.

C.2 ROLES and RESPONSIBILITY

C.2.1 LEGISLATIVE FRAMEWORK

The project has a transboundary nature, having the dam shared between Zambia and Zimbabwe.

The Zambezi River Authority (ZRA) is a transnational authority that deals with the Zambezi river, formed by the Council of Ministers of Zambia and Zimbabwe, the Board of Directors and the Executive Management.

The history of the Zambezi River Authority (ref. www.zaraho.org.zm) may be said to have begun in November 1964 when the Central African-Council appointed the Inter-Territorial Hydro-Electric Commission.

In May 1951 the Commission recommended the development of a dam at Kariba and hydro-electric power station. In June 1954 the Hydro-Electric Power Act was passed which provided for the establishment of the Federal Hydro-Electric Board charged with the function of Coordinating the generation and supply of electricity within the Federation.

In May 1956 the Federal Power Board was established pursuant to the enactment of the Electricity Act. This was a reconstitution of the Federal Hydro-Electric Board. The new Board was vested with the power to construct dams and power stations, to transmit electric power and sell same to Electricity undertakings. A hydrological data collection organization operating in each territory was also established.

In 1963, the Federation was dissolved. The integrated systems for the control of generation of power and its transmission continued to be operated and was fully developed as a single system under joint ownership and control of the two Governments of Northern and Southern Rhodesia under the Central African Power Corporation (CAPCO) which was established in the same year.

CAPCO was vested with the assets and liabilities of the Federal Power Board. The general function of CAPCO was to supply electricity to Electricity undertakings in the two territories while its conduct was regulated by a higher authority for power comprising two ministers appointed by each of the two Governments.

In 1987 the Zambezi River Authority Act was passed simultaneously in the two states of Zambia and Zimbabwe dissolving CAPCO and reconstituting it as Zambezi River Authority (ZRA).

CAPCO was divested of its electricity production and bulk distribution assets which were allocated to the National Electricity undertakings of the two states.

The ZRA was therefore left with the responsibility of the operation and maintenance of Kariba Dam Complex, investigation and development of new dam sites on the Zambezi River and analyzing and disseminating hydrological and environmental information pertaining to the Zambezi River and Lake Kariba.

ZRA is therefore assumed to be the dam Owner, intended as the organ charged to be responsible of the operation and maintenance of Batoka Dam.

The two national Plants linked to the dam can have different structures of Ownership and Operation, and that when will be appointed (by ZRA or by Zambia and Zimbabwe governments), will take the responsibility of the operation and maintenance of the Plant(s).

According to the structures of Ownership and Operation that Zambian and Zimbabwean countries and ZRA will put in place, the responsibility of maintenance of the dam and of the two plants can be assigned to different PMSs, that, in the frame of development of the manuals and of relevant implementation rules and structures, will organize (dividing and coordinating as appropriate) the work to be done and the limits and coordination of responsibilities. At the present stage of the design, and considering the importance to have an overall view of the Batoka scheme operation and maintenance requirements, the document is developed as one manual for the whole scheme.

It is assumed and recommended that the dam Owner (ZRA) is organized to be capable to manage, operate, maintain and protect the dam. In addition to this recommendation it should be noted that the dam Owner has liabilities to others under civil law.

C.2.2 MANAGEMENT STRUCTURE

The Owner of the Dam and of the Plants, within its structure or appointing external consultants, will build up one or more Plant Management Structure (PMS) that will be responsible of the management, operation and maintenance of the Dam and of the Plants. Such structure shall be such to cope with the need to properly operate and maintain the plant as described in parts C and D of the Dam Safety Plan, and to fulfill the reporting requirements described in Part D of the Dam Safety Plan.

C.2.3 SITE STAFF SKILLS AND TRAINING

The Batoka Dam and the two Power Houses are expected to be manned 24 hours per day.

Operation, inspection and maintenance of all aspects of the plant is to be undertaken by suitably qualified staff.

Training requirements related to operations of electrical and mechanical plant is described in dedicated section of this report. Training of staff is very important to achieve successful implementation of these Safety Plans. Surveillance inspections are to be conducted by staff trained and certified as competent in dam safety inspections. Surveillance data assessments and dam safety decisions are required from qualified engineers experienced in dam safety management.

C.3 SYNTHESIS OF RESERVOIR AND PLANT OPERATING CONDITIONS

C.3.1 GENERAL

All that follows has to be revised and updated with the development of the detailed design and construction of the Plant.

The characteristics of the plant summarized below are referred to the current status of the feasibility design.

The main components of Batoka HES basically include:

- A dam, about 180 m high, hosting middle outlets and spillway with plunge pool
- no. 4 underground power waterways, two on each abutment, with intakes, tunnels, shafts, penstocks
- no. 2 outdoor power houses, one for each bank, for a total installed power of 2400 MW.

The dam body hosts on its central part a spillway divided into several independent channels controlled by gates, returning the floods into the river into a pre-excavated plunge pool in the river bed. Two middle outlets are also hosted into the dam body.

Each bank hosts No. 2 underground power waterways that including:

- Four intake structures, two on each abutment, all located close to the dam
- four power tunnels, two on each bank, about 600-700 m long each with a diameter of 9.5 m
- four high surge shafts and 200-300 m penstocks, ending into manifolds that feed the powerhouse.

The two outdoor powerhouses are located downstream of the pre-excavated plunge pool, currently about 450 m from the spillway lip. The powerhouse building is about 175 m long and 40 m wide, disposed quite parallel to the steep rock front and slightly rotated with the river alignment.

The two powerhouses host No. 12 turbines (No. 2x6x200 MW) obtaining a total installed capacity of 2400 MW. Six main step-up transformers are located in "open air" at the back of each Power House, on a dedicated deck.

C.3.2 PLANT OPERATING CONDITIONS AND FACILITIES DESCRIPTION

This chapter describes the operating conditions of the power plant in respect of:

- hydraulic constraints
- availability of those equipment which contributes to the minimum requirements of the safety of the power plant

For what the hydraulic conditions are concerned, the power plant is in normal operation whenever the following conditions occur:

- Reservoir water level (RWL) between Full Supply Level (FSL) and minimum operating level (MOL)
- generating units in operation
- no ecological flow released through the ecological discharge valve

An "exceptional" operating conditions is identified whenever the above conditions are not met, and in such case we can have different scenarios as indicated in following table.

<i>CONDIITON</i>	<i>Description</i>	<i>event occurrence</i>	<i>RWL, m a.s.l.</i>	<i># units in op.</i>	<i>Q in each power tunnel, (max value in m³/s)</i>	<i>MLO release</i>	<i>SPILLWAY release</i>
A	normal op	continuously	MOL ÷ FSL	12=(1 ÷ 6)+(1÷ 6)	Yes (411.2)	no	no
B	Controlled flood release	possibly yearly	< Spillway sill	12=(1 ÷ 6)+(1÷ 6)	Yes (411.2)	yes	no
C	Controlled flood release / flood event	possibly yearly	< FSL	12=(1 ÷ 6)+(1÷ 6)	Yes (411.2)	if needed (*)	if RWL > Spillway sill (*)
D	Flood event	possibly yearly	> FSL	12=(1 ÷ 6)+(1÷ 6) (if possible, (*))	>= (411.2) if plant operates (*)	if needed (*)	Yes (*)

Table 8 - Operation of Batoka - hydraulic condition

(*) Following OPERATION CRITERIA IN CASE OF EXCEPTIONAL FLOODS (RESERVOIR ROUTING) to be included at par. C.4.6.

For ordinary and exceptional cases of operation, the description of opening and closure manoeuvres for each of the hydraulic devices (valves, gates, bulkheads, stoplogs) of the Plant is preliminarily indicated and shall be provided in detail at further design and construction stages in the next chapter C.4 of this report and in the relevant manufacturer's specific operation and maintenance plans.

In the same chapter C.4 the environmental flows prescriptions are reported, associated to the specific hydraulic devices devoted to the environmental releases.

The reservoir rating curve, that shall be used to find out at any moment the incoming flows and reservoir volumes from the readings of the reservoir levels will be included in detailed design phase in chapter C.4 of this report, together with all the rating curves of each hydraulic device.

The most important hydraulic features, such as spillway, middle level outlet, ecological release valves, etc. of Batoka HEP are described in the Feasibility Design, to which reference is made.

Each of the two power plants is provided with the following generating facilities and equipment:

- No.6 Francis turbines with a rated output of 200 MW

- No.6 Main Inlet Valve, Butterfly type
- No. 6 synchronous generators
- No. 6 main step-up transformers

C.3.3 NORMAL OPERATIONS DESCRIPTION

The operating conditions of the power plant can be assumed to be "normal" whenever the plant is operated:

- within the equipment capabilities in respect to their nominal hydraulic, mechanical, electrical conditions
- with all the safety measures fulfilled by the Operator, according to
 - the O&M manuals of each single part/equipment/system of the power plant provided by the original manufacturers
 - the emergency preparedness plan specifically prepared for Batoka project
- without any outage or out of service of those facilities and systems which grant the safe operation of the equipment, such as
 - fire-fighting system
 - water drainage system of the Dam and Power House
 - Dam monitoring devices
 - Dam pumping station
 - SCADA system, HVAC system for ventilation and air conditioning, etc.

The "emergency" condition operation refers to a status of the plant wherein the occurrence of some events could affect the overall safe operation of the plant. For example, the prolonged outage of the generating units compels the running of the back-up supply (i.e. Emergency Diesel set and DC batteries system) in order to guarantee the availability of safety devices, such as the Dam Pumping system, the fire-fighting and HVAC systems, etc. The configuration of the power supply in such an event is given in the next paragraphs.

SURGE SHAFTS

Four (4) surge shafts, one per each waterway have been introduced into the system with the aim of reducing the amplitude of pressure fluctuations by reflecting the incoming pressure waves and providing stability to the system with respect to the small load variations.

The shaft diameter, the maximum and minimum water level in the surge shaft and the proper throttle orifice size were defined according to the results of the hydraulic calculations at feasibility design stage.

In the development of the detailed design further hydraulic analyses are assumed will be conducted, adopting the most severe combinations of turbines opening and closure maneuvers, with some freeboards considered. Whenever, in order to improve the stability in isolated operation condition of only one group of units (one

power waterway) a control signal device (Level Bias) will be introduced in the turbine governing system, the functioning, setting and operation requirements of this device shall be inserted in this report.

C.3.4 EXCEPTIONAL OPERATIONS DESCRIPTION

In principle, and considering the limited excursion of levels available at Batoka project, the power plants are not envisaged to work outside of the range of reservoir water levels indicated for normal operation case.

LARGE TRANSIENTS

The occurrence of the so called "large transients" are to be considered within the "exceptional" operating conditions of the power plant.

On each power waterway a throttled type surge shaft is adopted in order to improve the efficiency in damping oscillation due to load rejection or load acceptance. A throttling orifice, placed in the T junction between the final section of the power tunnel and the shaft itself, can increase the damping effect of friction losses.

In the development of the detailed design it is assumed that specific simulations will be carried out, considering the inputs of wicket gate closure time provided by the turbine supplier and different most critical scenarios of opening/closure of turbines.

Any prescription of possible requested time before reloading each unit (that in principle can be reloaded as quick as possible, without any time restrictions) that might come out from the detailed design hydraulic analysis shall be inserted in this document.

C.3.5 POWER SUPPLY FOR BATOKA PLANT OPERATION

This paragraph depicts the power supply sources available for the proper and safe functioning of the Batoka Plant, fed by main and backup power systems.

INTRODUCTION

The auxiliary power system in BATOKA HPP is conceived in such a manner to grant the supply in either "normal" and "emergency" operating conditions, whereas these conditions are defined in terms of (n-1) contingency. Whenever the outage of the "main" feeder occurs, the system will be able to automatically switch over the back-up feeder maintaining the supplied loads in service.

The "core" of the distribution system consists of a medium voltage (MV) bus, fed from different sources, namely:

- some of the turbine-generator units of each power house, via distribution transformers of adequate rated capacity
- the Diesel Emergency set installed in each Power House
- the unit auxiliary transformers in each power house, feeding their own auxiliary equipment

- the Dam auxiliary board, through a MV line, fed by the MV distribution board of the each Switchyard via MV overhead lines;
- the Diesel Generating Set installed at the dam

Each MV bus is configured in double-busbars with a coupler breaker for automatic transfer switching.

For the purpose of this document, some critical loads have been identified for the safety of the plant operation, i.e.:

- the Dam Pumping Station (DPS): this station provides drainage and pumping service for water collected by the drainage galleries of the dam
- the Dam Auxiliary System (DAS), which feeds the equipment relevant to the hydraulic structures equipment (service gate, hoists, etc.), emergency lighting, etc.
- the Power House general auxiliary system, which feeds the main equipment and device pertinent to unit auxiliary system, SCADA and communication system, HVAC system, emergency lighting, firefighting system, dewatering system, DC supply

The above identified loads will be fed in any operating status of the power plant (with/o the turbine-generators running). At the DAS, there is the provision of a spare bay for an additional Diesel set.

EMERGENCY OPERATION OF THE DPS AND DAS

In normal service, the two switchgears (i.e. the Dam Pumping Station and the Dam Auxiliary Board) are foreseen to be fed from the Power House through MV lines. In this case, dam and switchyard auxiliary loads are fully fed, and power flows from PH to DPS and DAS.

The emergency condition is intended to be a condition where both PH generating units and relevant distribution system are not available. The control system of the power plant, under recognized operating conditions, will automatically put the Diesel Generator Set, located at the Dam Pumping Station, in operation. In doing so, the control system will also provide to shed the non-essential loads, to allow energisation of the essential (and, among these, critical) loads.

Therefore, the LV switchgear of the Dam Pumping Station can be fed by the Diesel Emergency set and energise the DPS and the DAS. The control system (or the operator) shall then close the breakers corresponding to the loads at both switchgears (DPS and DAS). Power flows from DPS to DAS and SWY.

C.4 PLANT HYDRAULIC CONTROL DEVICES OPERATION

C.4.1 GENERAL

Description of operation for opening and closure manoeuvres for any hydraulic control device at Batoka (valves, gates, bulkheads, stoplogs, and relevant cranes and lifting devices) will be provided in the frame of the detailed design, and shall be then duly included in this report.

In this chapter the guidelines and basic principles assumed for the operation of the hydraulic devices are given. It is recommended that specific operating procedures are implemented by the PMS, on the basis of the instructions provided in the present chapter, taking into account also the information and inputs of the O&M detailed manuals and drawings made available by the suppliers, to which reference shall be always made. Such procedures shall include at least the following scenarios:

- Hydraulic control devices operation under main power supply - remote and local control;
- Hydraulic control devices operation under back-up diesel power supply - remote and local control;
- Operation of back-up diesel generator and switch-over of power supply.
- Special conditions, if any, for first impounding.

It is worthwhile to recall that any maintenance or repair operation on gates or stoplogs shall be programmed and executed by qualified competent staff, possibly during dry season, avoiding as much as possible potential concomitance with floods events.

The calculation, verification, calibration etc. of the rating curves pertinent to the various discharge and control structures of Batoka project are described in the hydraulics analysis report of the Feasibility Design, to which reference is made.

The rating curves will be refined during the detailed design and construction phases, and for ease of reference and use they will be gathered here, including:

1. RIVER rating curve (at Power Houses location)
2. RESERVOIR rating curve
3. ECOLOGICAL DISCHARGE VALVES rating curve
4. MIDDLE LEVEL OUTLETS rating curve
5. SPILLWAY rating curves
6. POWER TUNNELS rating curves

C.4.2 INSTRUCTIONS FOR ECOLOGICAL FLOW RELEASE

The requirements for environmental discharge will be provided in the ESIA study.

The minimum discharge defined by the above-mentioned study, according to the water levels available in the reservoir within the minimum and maximum operating levels and to the Plant Operator choice, will be released by means of:

- the Power House units in operation (if at least one is maintained in operation 24 hours per day),
- the Ecological Discharge Device.
- the Spillway,
- the Middle Outlets.

Until the minimum operating level in the reservoir is not reached, the flood release shall be foreseen to be discharged:

- through the River Diversion scheme, until possible;
- through the Middle Outlets, as soon as possible compatibly with the Dam construction and reservoir water levels;
- through the Ecological discharge valves for reservoir levels above minimum operating level.

C.4.3 MIDDLE OUTLET UPSTREAM GATE OPERATION

GENERAL

Two Middle Outlet upstream gates are foreseen, one for each Middle Outlet.

The purpose of the upstream gate is to isolate the Middle Outlet waterways from the reservoir and allow inspection and maintenance activities on Middle Outlets structures and gates.

The upstream gate is operated the from the dam crest.

In normal conditions each upstream gate can remain closed or opened, upon the Plant Owner choice. The closed position is safer for the dam because avoids to maintain the water pressure inside the dam. It has the disadvantage that the gates remain for long period under water.

The layout and description of the upstream gate with relevant hoist and auxiliary equipment will be indicated here as developed in detailed design by the supplier.

OPERATION

The bulkhead will be closed whenever an inspection/maintenance/repair of the Middle Outlet steel lining and/or gates has to be carried out.

The gate shall be operated **under balanced pressure** conditions.

Before lifting the gate, the by-pass valve shall be opened in order to equalize the water pressure (time required to fill the whole waterway will be provided by the gate (and by-pass) supplier in detailed design).

When the water flows through the Middle Outlets, the upstream gate must be lifted as necessary (about 15 to 20m minimum above the bottom sill, to have the whole intake of the MLO fully opened (time required to lift the gate above the bottom sill, including the time to remove one rod, will be provided by the gate (and by-pass) supplier in detailed design).

Typically a locking device will allow the removal and the insertion of the lifting rods of the gate. Only for its inspection, maintenance or repair purposes the upstream gate can be raised up to the dam crest.

Before closing the gate, the MLO downstream gates must be closed. The gate will be lowered by gravity, from the dam crest.

C.4.4 MIDDLE OUTLETS DOWNSTREAM GATES OPERATION

Each Middle Outlet device will be equipped with two downstream gates, named gate no. 1 upstream and gate no. 2 downstream, both at the outlet section:

- The **gate no. 1** is an emergency gate that shall be closed only in extraordinary need of gate no. 2 maintenance, and it normally works fully opened. The gate will operate in balanced condition, but in case of need of sudden closure, the gate shall be able to work in unbalanced condition.

This kind of exceptional closure shall be carried out only in case of real emergency, and after having made all attempt to release the gate no. 2, because such operation implies high risk of cavitation and dangerous pressure pulsation in the whole downstream portion of the Middle Outlet conduit.

In case of necessity of closure in unbalanced condition, the operation shall be programmed to be executed minimizing its duration.

In case of need of gate no.1 inspection or maintenance, the gate no. 2 shall be closed to empty the Middle Outlet conduit.

All the operations gate no. 1 and gate no. 2 are conducted by means of the pertinent hydraulic units that are foreseen to be commanded directly locally and also connected to the Dam Control Building for remote control.

- The **gate no. 2** shall work fully closed or fully opened. It is normally closed and it is opened and closed in unbalanced conditions, at any need of Middle Outlet use. This gate is placed d/s the gate no. 1 and shall have a circular cross section.

In case of need of gate no. 2 inspection or maintenance, the gate no. 1, that is upstream, shall be closed to empty the Middle Outlet conduit between the two gates.

From an operational point of view, the Middle Outlets can operate within their operating levels, in pressurized conditions, with jet falling in the Plunge Pool.

For lower levels MLO flows can pass from pressurized conditions to free flow conditions, with progressive reduction of water jets and, in the transient conditions, with possible entrainment of air in the conduit. The possible temporary or exceptional use of MLO out of the design range of operation shall be object of investigation at detailed design phase (possibly through physical model tests).

It is therefore recommended to **use the Middle Outlets in pressurized conditions**, keeping them closed by means of the downstream gates for reservoir water levels below their minimum pressurized operating level. **Below such level the use of Middle Outlets is not recommended**, and in any case shall be limited in time to minimize risks of possible damages to the dam downstream face and Middle Outlet conduit.

It is recalled again that:

- The **upstream gate** shall be **opened always in balanced conditions**.
- The **downstream gate no. 1** can work only **in fully closed or fully opened conditions**
- The **downstream gate no. 2** can work only **in fully closed or fully opened conditions**. It shall **usually** work in **balanced conditions**, and **only in emergency case** it can work **in unbalanced conditions**.

The closing speed for both gates will be defined by the supplier, for any normal or exceptional condition.

C.4.5 RESERVOIR DRAWDOWN

The reservoir drawdown is foreseen in two cases:

- During the dry season to allow the rafting activities on the Zambezi river upstream the dam
- In case of necessity to inspect:
 - lower portions of dam upstream face or
 - the first portion of Power Tunnels upstream of the gate shafts

The reservoir drawdown operations shall be carried out according to specific procedures that will be defined during the frame of the detailed design of the hydraulic structures.

The requirements for lowering of the reservoir during dry season for rafting activities will be provided in the ESIA study.

The reservoir will be lowered, according to the water levels available in the reservoir within the minimum and maximum operating levels and to the Plant Operator choice, by means of:

- the Power House units in operation (if at least one is maintained in operation 24 hours per day),
- the Ecological Discharge Device.
- the Spillway,
- the Middle Outlets.

Same criteria for lowering the reservoir can be applied in case of necessity of inspection of lower portions of dam upstream face or the first portion of Power Tunnels upstream of the gate shafts.

C.4.6 SPILLWAY GATES OPERATION

The Spillway gates can operate from el. 738.6 to el. 762 m a.s.l.

The operation of the Spillway shall be programmed by the Plant Owner in function of:

- Power Production and energy market requirements;
- flood release requirements;
- water availability, monitored through the river and reservoir water levels.

OPERATION

The sequence and degree of aperture that shall be adopted for gates opening and closure will be defined in detailed design phase, considering the Spillway physical hydraulic model tests that are assumed will be conducted, and taking into account that for ordinary flows the use of the spillway can be limited to some gates only, while for higher flows in principle all gates will be required to function simultaneously.

Analogue procedure will be reversely defined and applied for gate closure when the incoming flow decreases. The automatism for this procedure will be implemented by the gate supplier.

The control of the gates will be made locally (on the control unit foreseen near each gate) and remotely from the Dam Control building.

In case of one gate is blocked, or for any reason out of operation, when the Spillway shall be used, depending on which gate is out of operation the sequence defined for the normal operation criteria shall be rearranged consequently, with the aim to obtain the configuration of jets discharging in the pool as close as possible to the one originally envisaged.

The intervention of release, inspection, maintenance or reparation on a blocked gate shall be conducted by isolating the bay upstream side by means of the stoplogs, which use and operation is described in the next paragraph.

C.4.7 SPILLWAY STOPLOGS OPERATION

GENERAL

The purpose of the Spillway stoplogs is to allow the inspection of the Spillway structure and radial gates.

The stoplogs set will be made of **multiple interchangeable elements**. The elements will be designed to be lowered or raised in the slots in a vertical position after the release of the lifting beam by suitable grappling beam, of a self-latching and unlatching type.

OPERATION

The Spillway stoplogs will be operated by the crane, running along the dam crest structure.

The lifting and lowering of the stoplog elements is done only **under balanced head**, under zero flow. This means that, before opening or lowering of the stoplog, the radial gate must be completely closed.

The Spillway Stoplog **INSERTION PROCEDURE** is articulated as follows:

1. Ensure that the Spillway radial gate is closed
2. Engage the lifting beam with the crane
3. By mean of the crane, lower the lifting beam and engage the stoplog element which lies in the stored position.
4. Lift the stoplog element and check for correct stoplog engagement
5. Lower the stoplog element in the sluice till it reaches the sill
6. When the stoplog rests on the sill beam (the lifting beam automatically disengages)
7. Lift the beam and repeat steps from (3) - (7) with the others stoplog elements

The Spillway Stoplog **REMOVAL PROCEDURE** is articulated as follows:

- Ensure that the Spillway radial gate is closed
- Engage the lifting beam with the crane hook
- Lower the lifting beam in the sluice to engage the upper stoplog element
- Lift the upper stoplog element under unbalanced conditions for 100mm approximately
- Wait until balanced pressure condition is established.
- Lift the stoplog until the operation level and store it in the proper structure (the lifting beam automatically disengages).
- Lift the beam and repeat steps from (2) - (6) with the others stoplog elements

The details and procedures for operating lifting beam and the movement of the hook during insertion and removal of the stoplog will be provided by the supplier in detailed design phase, and included in the final version of the operation manual, as well as the stocking area and stoplogs handling and stocking details and procedures.

C.4.8 INTAKE BULKHEAD GATES OPERATION

GENERAL

The bulkhead gates will be installed in the intake tunnels upstream from the intake wheel gates. The main purpose of these gates is closure of the waterways to allow **maintenance** and **inspection** of:

1. the intake wheel gates
2. the power tunnels
3. the penstocks
4. the Main Inlet Valves.

OPERATION

Bulkhead gate is foreseen to be of slide type operated by stationary cable hoist, placed at the shaft top. Gate and hoist are assumed to be connected directly.

The bulkhead gates shall normally be kept in open position. For this reason locking devices are foreseen at the upper floor of the shaft.

Closing of the bulkhead gates shall be done **under balanced pressure** condition. For this reason, before the bulkhead are closed, the closure of the fixed wheel gates and/or main inlet valves must to be assured.

Opening of the bulkhead gate shall be done **under balanced pressure** condition.

In order to equalize the water pressure on both side, one by-pass valve is foreseen to be incorporated into the upper gate leaf. Before the bulkhead is lifted, the by-pass valve must be raised as necessary to equalize the water pressure filling the gap between the bulkhead and wheel gate. The gate normal opening speed will be set by the gate supplier, it is however recommended to maintain as far as possible low velocities (in the range of 0.5 m/min).

C.4.9 INTAKE WHEEL GATES OPERATION

GENERAL

Two gates of wheel type are foreseen to be placed in each power waterway of the power plant. These gates are installed in the intake tunnel downstream from the bulkhead gates.

The main purpose of these gates is the closure of the waterways to allow:

1. **maintenance** and **inspection** of:
 - the power tunnels
 - the penstocks
 - the Main Inlet Valves
5. **emergency closure** in case units are under load rejection and wicket gates and main inlet valves fail to close.

OPERATION

Each wheel gate will be operated by an oil pressure servomotor, mounted at the top of the shaft. Connection between the gate and piston rod is foreseen to be made by means of flexible connected lifting rods.

The wheel gates shall be normally kept in open position, by means of locking devices on gate shaft roof.

The wheel gate shall be used as an emergency gate. Closing of the wheel gate is done **under unbalanced pressure** condition. The wheel gate is foreseen to be capable to close under the full flow in case of emergency. For this reason, the wheel gate will be designed to be able to close by its own weight (including lifting rods) and by water column on the top of it, under any flow condition. While closing, the servomotor can act as a brake.

The gate is opened by oil pressure of the servomotor. Opening of the bulkhead gate must be done **under balanced pressure** condition. In order to equalize the water pressure on both side, one by-pass valve is foreseen to be incorporated into the upper gate leaf. Before the wheel gate is lifted, the by-pass valve must be raised to equalize the water pressure. The gate normal opening speed of the gate will be set by the supplier, it is however recommended to maintain in any case low velocities (in the range of 0.1 m/min).

C.4.10 POWER WATERWAYS EMPTYING AND FILLING OPERATION

The **EMPTYING PROCEDURE** of one waterway shall be defined in the detailed design, identifying what are the steps of closing and opening of each hydraulic or electric device, and relevant timing or possible constraints, taking into account the rate of velocity for the opening and closure procedure of the gates, and details about gates functioning as will be provided in relevant EM-HSS equipment operation and maintenance manuals.

In case power waterways emptying is necessary, a large amount of water (until the river water level is reached) can be discharged in any condition through the Power House.

Thereafter penstocks emptying pipes, foreseen for each of the manifold branches, provided with gates valves manually operated, allow to discharge only the last volume of water inside penstocks, below the river level. Water inside draft tube, downstream of main turbine valves, will be drained by the dedicated pipes.

The details and the hydraulic calculations of the penstocks emptying procedures and relevant time requirements will be developed at detailed design stage.

The **FILLING PROCEDURE** of one Power waterway after an emptying process shall be defined in the detailed design, identifying what are the steps of closing and opening of each hydraulic or electric device, taking into account that the selection of the water pressure rising rate in the Power Waterways system shall be fixed considering any requirement of the steel penstocks prescribed by the Plant Contractor.

C.4.11 ACCESS TO EMPTY POWER WATERWAYS FOR INSPECTION & MAINTENANCE PURPOSES

The inspection of the horizontal part of tunnels downstream of the gate shafts can be made, once empty, getting access from the watertight doors foreseen to be available on the external side of each tunnel, upstream of the steel lined portion.

Inspection of steel lining of penstocks e Manifolds, as well as the surge shaft can be done accessing through:

1. Tunnels Watertight doors above mentioned, for their horizontal stretch (the surge shaft crest can be reached by stairs from external side).

2. Manholes on the upper bend of the steel lining penstocks (a chamber with hoist is foreseen to be available for each penstock, accessible from the dedicated upper access tunnel serving also as drainage tunnel).
3. Manholes upstream of the Main Inlet Valve, accessible from the Power House.

Access must be restricted to qualified people appointed and authorized by the PMS. A strict control shall be done in such exceptional maintenance operations that no free access is given to the empty tunnel.

Before entering the empty tunnel it must be verified that (if water level of the reservoir is not maintained below the tunnel invert level) the upstream gates are closed and don't leak, and that the conditions of water presence, temperature and humidity conditions inside the tunnel are compatible with the safety of the workers. It shall be implemented a mobile communication system between people entering in the tunnel and people governing and monitoring the gates and the reservoir.

The exceptional inspection of the portal upstream of the gate shaft can be made only if the reservoir is lowered and maintained below the invert level of the tunnel.

Unless it is possible and convenient to lower the reservoir level (by means of the MLO) below the invert level of the tunnels, and to maintain such condition for the whole period needed for maintenance, the inspection and maintenance operations in the tunnel shall be conducted having closed the gate shaft gates, and being verified the certainty of such closure before entering in the tunnel.

Detailed procedures will be developed in detailed design phase and inserted in the final operation manual. As a general prescription, it is here recalled that the inspection of the tunnel should be programmed preferably dewatering one tunnel at the time, or in any case two at the time but not the two tunnels of the two plant simultaneously (unless strictly necessary), and in any case this exceptional operation shall be programmed in advance to allow to manage the consequences of a long period of plant(s) stop, and any period of water discharge through the Spillway/Middle Outlet.

The inspection of the main tunnel (and the eventual repair or maintenance operations required) shall be done only by skilled personnel, instructed and authorized by the Plant Owner for the operation required, with the assistance of a design specialist.

C.4.12 MAIN INLET VALVES OPERATION

GENERAL

Ten main inlet valves (MIV) are foreseen to be placed upstream each hydraulic unit.

The main purposes of these main inlet valves are the following:

- **Emergency closure**, with maximum flow under all extreme conditions, including the transient forces caused by water-hammer. Such condition occurs with a turbine accident as well as the guide vane

fails to close. The prompt closure of the valve assures safety of the turbine unit and avoid the turbine over-speed.

- **Closure for Normal shut down** of the unit, under balanced pressure conditions with the wicket gates completely closed. The closure of the valve prevents the leakage of the wicket gates for a longtime and reduces the water loss.
- Closure for **maintenance** of the unit, under balanced pressure conditions with the wicket gates completely closed.

DESIGN

The MIV is made by two major parts:

2. Valve body that includes the driving mechanism, valve body, valve disc, valve shaft, shaft seal components, automatic locking oil cylinder, hydraulic system and so on.
3. Auxiliary components, that includes bypass valve, bypass pipe, inlet pipe, outlet pipe and expansion joint, the hydraulic system and so on.

The MIV has two seals: the main seal (also named work seal) and maintenance seal. When the main seal is working normally, the maintenance seal is released. If the valves need maintenance, the maintenance seal is used.

OPERATION

The MIV opening is driven by oil operated servomotor; during the valve opening, the counterweight is lifted up to provide energy for closing. In fact the MIV closure is done by **gravity**, with counterweight.

Normal opening and closing will be **under balanced pressure**, with the by-pass valve opened and wicket-gates in closed position: suitable interlocks prevent the valve opening when pressures have not the same values.

When the valve is fully opened, the pressure of hydraulic system is maintained automatically. The hydraulic system will keep the oil pressure automatically when the valve is full open. The pump will stop when the oil pressure reaches the upper limit whereas the oil pump will start when the oil pressure drops below the lower limit. This function is available when the full open signal is sent out.

The hydraulic system has a redundancy closing function. This function allows the oil pressure to enter into the piston rod chamber with the purpose to help the valve closure. This function is not activated for normal or emergency closures. The redundancy function shall be activated when the friction force will increase, typically after many years of operation.

C.4.13 DRAFT TUBE GATES OPERATION

GENERAL

What follows refer to one power house and it is applicable of both Power Houses of Batoka Project.

Each powerhouse has six hydraulic turbines. Downstream of each turbine there is a draft tube that, after the elbow, is divided in two parts by a pier. Each draft tube has two sliding draft tube gates, one for each sluice of the draft tube.

The draft tube gates will serve for maintenance purposes only, in fact their main purpose is to isolate the turbine and draft tube from the tailrace. During normal operation these gates will be kept in the fully open position by a self-engaging and disengaging safety latch conveniently located either on the servomotor top cover or on its bottom pedestal.

The draft tube gates will be closed to dewater and to carry out maintenance in the turbines and draft tubes.

OPERATION

The gates will be raised and lowered by an oil operated servomotors. The draft tube gates are usually operated under **balanced pressure** on upstream and downstream sides. To this purpose each gate will have its own by pass system provided to allow the filling of the draft tube (with times that will be indicated by the gate supplier in detailed design phase). When the pressure on both sides of the gate is balanced, a pressure switch gives the consent for opening.

The control of operations of the draft tube gates can be done from local control panels and from Power House control building.

In case of maintenance the gate is lifted by a monorail crane.

C.4.14 DRAFT TUBE STOPLOGS OPERATION

GENERAL

For each draft tube two draft tube sliding gates are foreseen (see previous paragraph). Downstream these gates there is a slot for the draft tube stoplogs. There are typically two sets of draft tube stoplogs that will allow maintenance for two units at the same time.

The purpose of the draft tube stoplogs is to allow the inspection and maintenance of the draft tube sliding gates and draft tubes.

Each stoplog set of the draft tube is divided in elements. The bottom and top elements are typically not interchangeable because the top element is designed with a top seal against the sluice upper face. The elements are designed to be lowered or raised by suitable grappling beam, of a self-latching and unlatching type, they are operated by the draft tube crane from upper floor of PH.

In normal condition, when the generating units are working, each element of the stoplog is stocked in the relevant storage area. Steel grid covers are foreseen for closure the stoplogs slots at power house upper floor. During maintenance of powerhouse electro-mechanical equipment, the stoplogs are placed on both sluices of any draft tube, to close the water flow from the tailrace side.

OPERATION

The draft tube stoplogs will be operated by the relevant crane, running along the power house deck structure at upper floor. The storage area for the draft tube stoplogs is in the close proximity of the sluices and accessible by the hoisting facility.

The lifting and lowering of the stoplog elements will be done only **under balanced head**, under zero flow. This means that before opening or lowering of the stoplog it has to be sure that units are stopped and, preferably, draft tube sliding gates are closed.

The Draft tube Stoplog **INSERTION PROCEDURE** is articulated as follows:

- Ensure that the unit is stopped
- Ensure that the draft tube sliding gates are closed
- Engage the lifting beam with the draft tube crane
- By mean of the draft tube crane lower the lifting beam and engage the stoplog element which lies in the stored position.
- Lift the stoplog element and check for correct stoplog engagement
- Lower the stoplog element in the sluice till it reaches the sill: during this operation make sure that the beam guide shoes are properly engaged with the rails fixed in the concrete.
- When the stoplog rests on the sill beam, the lifting beam automatically disengages
- Lift the beam and repeat steps from (4) - (8) with the others stoplog elements

The Draft tube Stoplog **REMOVAL PROCEDURE** is articulated as follows:

- Engage the lifting beam with the crane hook.
- Lower the lifting beam in the sluice to engage the upper stoplog element: during this operation make sure that the beam guide shoes are properly engaged with the lateral fixed in the concrete.
- Lift the upper stoplog element under unbalanced conditions for 100mm approximately
- Wait until balanced pressure condition is established.
- Lift the stoplog until the operation level and store it in the proper structure: the lifting beam automatically disengages.
- Lift the beam and repeat steps from (2) – (6) with the others stoplog elements

The description of the lifting beam and the movement of the hook during insertion and removal of the stoplog will be provided by the supplier in detailed design.

C.5 OTHER PRESCRIPTIONS FOR CIVIL WORKS OPERATION

C.5.1 GENERAL

The inspection of the works and the areas downstream of the dam shall be frequently conducted with the aim to find and measures any signal of potential leakage or static problems to the structures connected with the operation of the plant.

The monitoring of all the instrumentation foreseen shall be regularly conducted, following all the prescriptions that are provide in part B of this Dam Safety Plan (to which reference is made for all instrumentation monitoring activities), and that shall be updated and detailed during the development of detailed design and construction phases.

In addition, particular attention shall be paid to the hydraulic steel structures when they enter into operation, and to the Dam also in the upstream zone (as far as possible to be inspected from upstream and from the dam galleries).

All the above mentioned maintenance requirements are described in the Part D of the Dam Safety Plan (to which reference is made), and that shall be updated and detailed during the development of detailed design and construction phases.

Other specific prescriptions for the use or operation of the civil works will be typically provided during the detailed design and construction phases, to be included here.

C.5.2 RESTRICTED AREAS

In general is mandatory to restrict the access to the Plant to the authorized people only.

A tentative preliminary list of specific locations that require to be locked for safety reasons is provided hereinafter. The PMS shall maintain in good status and available for inspection of authorized people the accesses, the gates or doors or fences and relevant locking devices.

- Dam galleries
- Dam cable shaft
- Dam control building
- Dam crest and abutment yards
- Dam spillway gates control room
- Dam middle outlet gates control room
- Dam pumping system control building
- Dam pumping system pits
- Power Tunnels access tunnels to watertight doors and manholes

- Power Houses
- Power Houses diesel generator buildings
- Switchyards
- Switchyards control building
- Gate shafts and relevant yards
- Surge shafts and relevant yards
- Reservoir slopes around the Power Tunnel intakes.

It is to underline that the specific transboundary nature of Batoka Project implies the possible necessity of having border control posts on dam abutments, and specific regulations and rules for the access to the dam (for personnel working at Batoka Plant) and for persons that want to cross the border, to be defined and detailed by the Zambian and Zimbabwean Governments and implemented by the relevant Authorities.

The access inside the Power House, Switchyard and Dam control building and to the zones where there are EM equipment in tension (like the transformers) shall be restricted to the only persons authorized by the PMS, that shall be aware of the functioning of the equipment and control system.

At site, in visible places, panels shall be provided to inform clearly about the above prescriptions and limitations.

The control room of the Power Houses shall be manned, to allow adequate control of the Dam and Power Houses behavior in real time.

All the EM and HSS equipment present in the Power Houses shall be object of operation and maintenance activities as prescribed in the relevant manuals of the supplier.

The ordinary maintenance and cleaning of civil works and architectural components is required for the functionality and durability of the Dam, Shafts, Power House, Switchyard, as well as for all the other civil work structures, and it shall be therefore considered and planned as a part of the plant operation program, as described in part D of this report.

C.5.3 LOADS AND ACCESS LIMITATIONS

There are typically some restrictions for the loads allowed on the Power House erection bays and on dam crest loading areas.

Some zone are not designed for heavy loads and in others there are loads limitations and special prescriptions (for instance in power house erection bay for the exceptional case of two units erected simultaneously), or specific areas for stoplogs or other heavy equipment stock.

Also there will be restrictions for the access to vehicles on some areas: some zones will be not designed for vehicular loads and in others there will be loads limitations.

The stoplogs for the Power House tailraces shall be stocked in the specific areas identified by the detailed design, and the same applies for the stoplogs for the Dam spillway.

The prescriptions will be provided in detailed design and included in this manual with appropriate plan drawings showing areas and limits of loads, as required.

At site, in visible places, panels shall be provided to inform clearly about the above prescriptions and limitations.

C.5.4 TRANSFORMER OIL WATER RECOLLECTION SYSTEM OPERATION

Here below there is a brief typical description of the Power House transformers oil recollection and disposal system that will be defined and sized in detailed design.

Below each transformer a small basin partially filled with gravel will recollect in case of fire event the firefighting system waters and any oil leakage.

The basins will be connected to a steel pipe that conveys all the oil and water in a dedicated tank, buried at the extremity of the Power House.

In the tank the oil and the water are separated by gravity. Oil is foreseen to be recollected and disposed appropriately, water to be discharged in the river.

The final recollection tank will have a volume capable to contain the maximum possible amount of fire extinguishing waters, plus the transformer oil.

Two internal walls are also foreseen to facilitate the oil water separation, in order to avoid in any case that the oil is discharged directly in to the river.

There is a water bottom scour pipe on the bottom of the final recollection tank, for water discharge, discharging directly into the river. A portable pump is foreseen for oil disposal.

Two cases will be considered:

Case 1) Transformers oil leakage:

Should any one of the transformers have some oil leakage, the basin beneath transformers will collect the oil and dispose it in the final recollection tank. Such oil will be not pumped out by the water pump, since the corresponding volume is considered in the dead capacity of the final recollection tank.

In case of important leakages oil must be recollected from the final recollection tanks by means of portable pump, as described in the next case.

Case 2) Transformers fire:

Should any of the transformers be damaged by fire, the tanks beneath transformers will collect the oil that is discharged, together with the water used for the fire extinguishing, and dispose the oil and the water in the final recollection tank.

After some time, once oil and water are separated, the floating oil stratum in the final recollection tank will be removed by use of a portable pump on hand at the PH Mechanical Store.

Such pump is utilised by the appointed personnel who will manually insert the pump into the tank and position it to pump out only the oil which will be disposed of in barrels.

After this operation the water still present in the tank is foreseen to be discharged by manually opening the valve of the bottom outlet pipe.

C.5.5 PLUNGE POOL AND TAILRACE CLEANING

The tailrace hole (in front of the exit of the Power Houses draft tubes) shall be maintained free of stones and debris, to avoid clogging of the waterways of turbine outlets.

To this purpose periodic check of the tailrace hole shall be conducted (see Part D of the report), and in case it is found material accumulated in the bottom of the tailrace hole, at the exit of the draft tubes, if such deposited material is above the invert level of the draft tube canal, it shall be removed.

Material can be removed by using a barge or by similar equipment. Such operation shall be done with the correspondent unit not in operation.

Debris, loose rock elements or boulders accumulated in the plunge pool bottom do not constitute a problem, until they remain inside the pool. If, for instance after a flood event or a severe condition of use of the spillway, such material is transported by the currents out of the pool, if it falls inside the tailrace the above recommendations of tailrace cleaning apply.

After a flood event or a severe or prolonged condition of use of the spillway, it is recommended to check the status of the dam downstream toe. See Part D of the Dam Safety Plan.

C.5.6 USE of RESERVOIR FLOATING BARRIER

Floating barrier is typically conceived as instrument to protect from entrance of debris and trunks the following hydraulic works:

1. Middle Outlet,
2. Power Tunnel Intakes
3. Spillway.

Its use is not strictly necessary but recommended for the first impounding (especially to protect MLO and Power Waterways intakes) and also for the operation period, especially for the protection of the spillway.

Also for the emergency case (exceptional events) of reservoir drawdown, it can be used for the subsequent re-impounding.

If a barrier is adopted, maintenance and periodic cleaning of the material accumulated against the barrier shall be executed by the PMS, accessing to it by means of access roads surrounding the reservoir in the zone near the dam, or by barge, with frequency depending on the ground condition (floods, accumulation of debris), as set in Part D of Dam Safety Plan.

More details in this regard are assumed will come from the detailed design and construction phases.

C.5.7 ACCESS TO DAM AND RELEVANT GALLERIES

The access to the galleries inside the dam body will be permitted by the access galleries foreseen on both banks. From the dam crest (near the abutments) there will be the entrance to the upper gallery, from which also the cable shaft inside the dam and the pendula shafts will start.

It is strongly recommended to do not access with any vehicles the dam downstream face benches, with the exception of the wider ones designed as access roads for the galleries or HSS devices.

In any case access inside the galleries with vehicles shall not be allowed, because the galleries are usually not ventilated to cope with vehicles gas emissions.

All benches of the dam downstream face are typically not protected with any guard rails or fences, therefore if it is needed to pass with any vehicle on the dam, also along the access roads, in case of need for maintenance or repair works, a temporary fence shall be built where it is intended to get access, adequately sized to prevent any accident or falling down.

The gates giving access to the dam galleries shall be kept closed, for safety reasons, and the entrance shall be allowed to authorized persons only.

The lowest galleries usually have no direct access at their level. They are accessible only from the dam downstream face by shaft, typically equipped with stairs, for pedestrian access, and with a hoist, to lower equipment for maintenance, drilling or grouting operations. Here also no permanent ventilation system is usually present; it shall be provided on temporary basis in case equipment are introduced and prolonged works shall be carried out inside these galleries.

The same shafts serve the pumps pits on their bottom.

A cable shaft, equipped with a lift (for tools, not for persons) and staircase, puts in communication the galleries at different elevations. In case of emergency it can be used to enter or escape from another gallery.

In occasion of the periodic monitoring of the drainage system inside the galleries, it is recommended to carry out a cleaning of any obstruction, debris or other element that can be an obstacle to the discharge of the water.

C.6 ORGANIZATION, TRAINING AND FACILITIES FOR PLANT OPERATION

C.6.1 ORGANIZATION OF THE PLANT MANAGEMENT STRUCTURE

Details of the operational structure are defined by the Plant Owner and Plant Management Structure (PMS).

The PMS will be responsible for the maintenance of the dam, including the dam safety aspects. PMS will also be responsible for the operation of the dam and coordination of operation of the power houses, and in particular the operation of the hydraulic control devices.

They will prepare the reservoir operating rules for the power supply, reservoir and river base flow demand rules, taking into account the needs of an integrated operation of both Batoka Power Houses as well as the Batoka-Kariba cascade.

They will fill the formats provided at par. E.7.4 and they will use them for all needs.

Within this frame PMS will also develop daily operating arrangements for water releases from the reservoir.

The PMS defines how much staff shall be employed for the operation and maintenance of the plant. The following is a minimum anticipated requirement to carry out the basic dam maintenance and safety requirements for Batoka Plant:

- For operation of the flow control gates, valves and hydraulic devices, one operator (preferably two men for safety reasons) available when required.
- Monthly inspections and reports will require one man (preferably two men for safety reasons) to carry out the inspection and monitoring.
- It is recommended that the main valves and gates maintenance (both mechanical and electrical) are covered by a maintenance contract under PMS.

Additional people will be required as and when necessary to carry out larger maintenance work or specialist work.

C.6.2 OPERATORS TRAINING

The operators shall undergo a training programme covering the technical aspects of the dam and plant equipment and their operation. In view of the new commercial model where the scheme will be developed under the BOT and the possibility of an independent operator being engaged to run the plant for the agreed operation period, the training that will be conducted for the BOT O&M Contractor should include the Operators from the utilities and the Authority.

The programme shall cover both the features and performance of the equipment and their operation, to be illustrated both through off-site theoretical and on-site practical training sessions. These training sessions

should be carried out by the manufacturers of the equipment or someone else with an intimate knowledge of the equipment and of the plant functioning.

Specific training to learn how to use, monitor and maintain the instrumentation installed at dam is required.

Operators must have a certificate of competence, which will be recorded in a training register.

Maintainers must have a certificate of competence, which will also be recorded in a training register.

Both the operators and the maintainers must attend training courses covering:

1. The dam safety in emergency situations, through which they should gain a comprehensive awareness and competence in emergency identification and emergency actions.
2. Personal and general safety in the workplace.

The above training should be fully documented in a training register.

C.6.3 EQUIPMENT AND FACILITY REQUIREMENTS FOR BATOKA PLANT

In addition to the equipment installed (gate hoists, controls and emergency diesel generator) in detailed design it will be identified if there will be other equipment needed for operation and maintenance of the plant, for instance items (like for instance mobile cranes, or barges, or special tools) that might be required for exceptional maintenance cases.

A full list of the spares provided by the manufacturers and suppliers shall be added to this O&M manual by the PMS for a prompt consultation in case of need.

The list shall be carried out after check of all the items present on site filling a format like the one provided in sake of reference in the next paragraph.

C.6.4 FORMAT FOR SPARE PARTS LIST

Add lines and duplicate as far as necessary.

BATOKA SITE SPARE PARTS LIST											
LOCATION		ITEM		AVAILABILITY							
area	room	Description	Quantities	Taken in date	By (insert name and signature)	Returned in date	By (insert name and signature)	Used or consumed in date	By (name and signature)	To be re-ordered. Ordered in date	By (name and signature)
<i>PH</i>	<i>Mechanical Store</i>	<i>Pumps for oil dewatering</i>									
<i>Dam</i>	<i>Control Building</i>	<i>Mechanical tools box</i>									

Table 9 - Table of Batoka Site spare parts list format

C.6.5 CONTACTS FOR ROUTINE OR ALERT PROCEDURE IMPLEMENTATION

The data gathered from the instrumentations, as described in the Parts B, D and E of the Dam Safety Plan, and other reports and data collected in ROUTINE or ALERT conditions (ref. Part B of Dam Safety Plan) shall be forwarded to the following contacts:

Plant Management Structure				
Name	Position	Telephone	E-mail	Mail address

Table 10 - Contacts for Routine or Alert procedure implementation

C.6.6 CONTACTS FOR EMERGENCY or ALARM CASES

In case of need to trigger an ALARM condition, or in case of need to implement dedicated procedures described in Part E of the Dam Safety Plan, the addresses reported here below shall be immediately contacted:

Plant Management Structure				
Name	Position	Telephone	E-mail	Mail address

Local/Governmental Authorities				
Name	Position	Telephone	E-mail	Mail address

Table 11 - Table of Contacts for emergency or alarm cases

PART D - MAINTENANCE PLAN (Preliminary Plan)

D.1 INTRODUCTION

D.1.1 CONTENT AND STRUCTURE OF THIS PART

This is the **PART D "MAINTENANCE PLAN"** of the Batoka Dam Safety Plan.

This part of the report, and its references, comprises the guidelines for the Maintenance Plan of the Batoka Plant, including the dam, power waterways, power house and other appurtenant structures.

It outlines the operation and maintenance activities and procedures relevant to the Batoka Dam and Hydro Power Plants, to be detailed and implemented by the Project Management Structure that will be appointed by the Owner(s) of the Plant.

Being the design at Feasibility stage, this document has a Preliminary nature, being necessary to be developed and detailed during project implementation. The final plan is due prior to 6 months before initial filling of the reservoir according to the development and detail of the design, and further on according to the construction of the plant itself.

The project has a transboundary nature, having the dam shared between Zambia and Zimbabwe.

The Zambezi River Authority (ZRA) is a transnational authority that deals with the Zambezi river, formed by the Council of Ministers of Zambia and Zimbabwe, the Board of Directors and the Executive Management, and it is assumed to be the organ charged to be responsible of the operation and maintenance of Batoka Dam. The two national Plants linked to the dam can have different structures of Ownership and Operation, and that when will be appointed (by ZRA or by Zambia and Zimbabwe governments), will take the responsibility of the operation and maintenance of the Plant(s).

According to the structures of Ownership and Operation that Zambian and Zimbabwean countries and ZRA will put in place, the responsibility of maintenance of the dam and of the two plants can be assigned to different PMSs, that, in the frame of development of the manuals and of relevant implementation rules and structures, will organize (dividing and coordinating as appropriate) the work to be done and the limits and coordination of responsibilities. At the present stage of the design and considering the importance to have an overall view of the Batoka scheme operation and maintenance requirements, the document is developed as one manual for the whole scheme.

As far as the Batoka Plant MAINTENANCE instructions are concerned, it is firstly illustrated the procedure to be adopted for the inspection and maintenance of the Plant, and in the subsequent chapters procedures are provided, as far as civil works are concerned, dedicated to each single work constituting the plant.

It is assumed that Electromechanical and Hydraulic steel structures equipment and devices detailed Operation and Maintenance manuals will be provided by relevant suppliers before Plant Commissioning: such manuals will be gathered and make part of the detailed Operation and Maintenance manual of the Plant.

D.2 PROCESS OF INSPECTION AND MAINTENANCE

D.2.1 GENERAL APPROACH

The global process of operation and maintenance of a Hydro Power Plant is articulated through two types of actions: the preventive maintenance and the extraordinary maintenance.

While the second one is applied in a specific case of malfunction or accident on a part of the plant, the preventive maintenance is ordinarily applied during the normal operation of the plant.

In general terms, the guiding principle of preventive/predictive maintenance is the regular and systematic application of engineering knowledge and maintenance attention to equipment and facilities to ensure their proper functionality and to reduce their rate of deterioration.

In addition to dedicated engineering, preventive/predictive maintenance encompasses regular examination, inspection, lubrication, testing and adjustments of equipment without prior knowledge of equipment failure. Preventive/predictive maintenance also provides the framework for all planned maintenance activity. The result is a proactive (rather than a reactive) environment, optimizing equipment performance and life.

It includes actions which extend the life of equipment and avoid unnecessary failures by substituting selective programmed effort for "fix it when it fails" maintenance.

The aim of any intervention is to promote cost-efficient decisions, to minimize the overall maintenance costs by means of preventive maintenance, following decision logic in terms of cost efficiency:

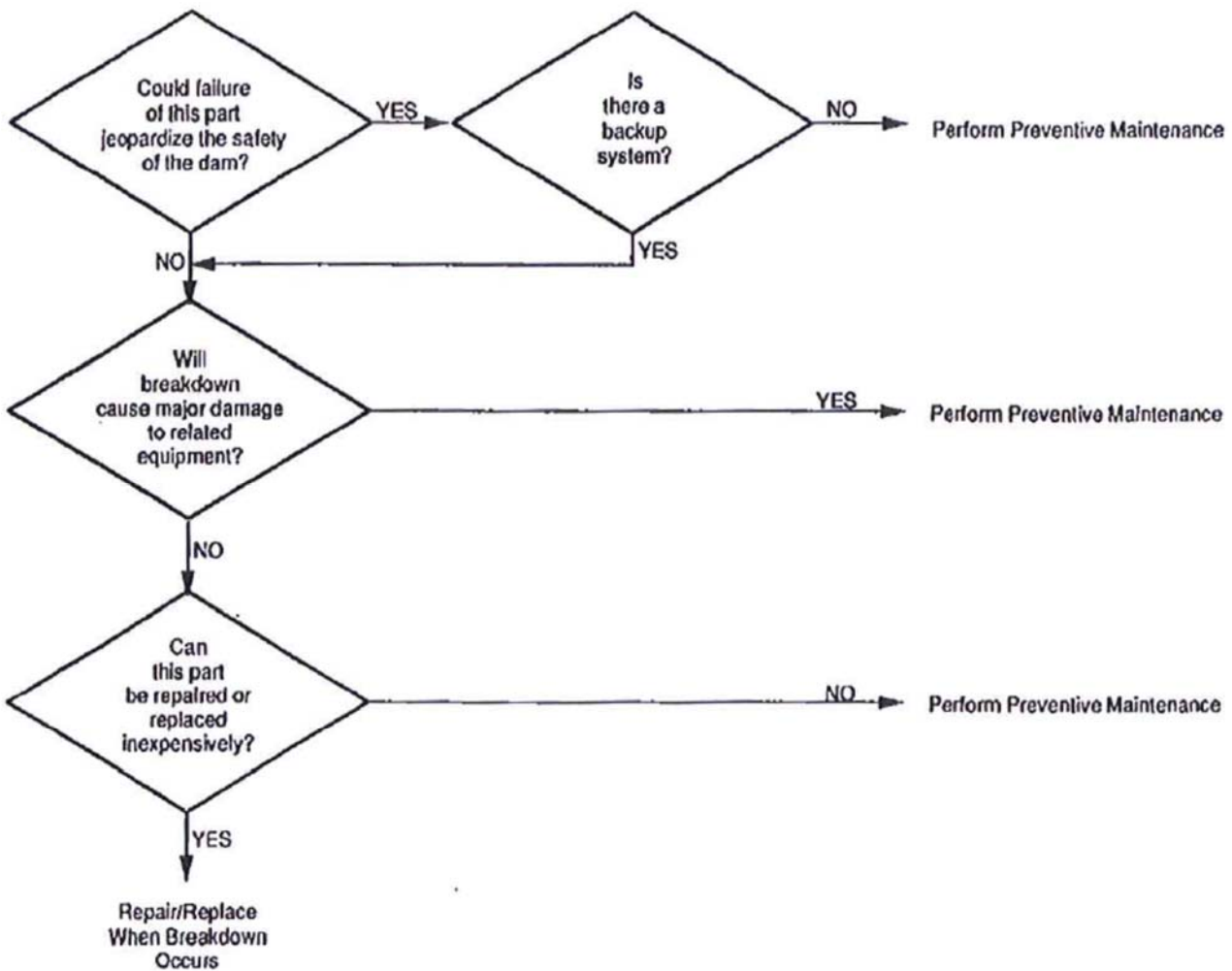

The conceptual process of implementing the Operation & Maintenance program is recalled here below for the benefit of understanding the general principal phases of the process.

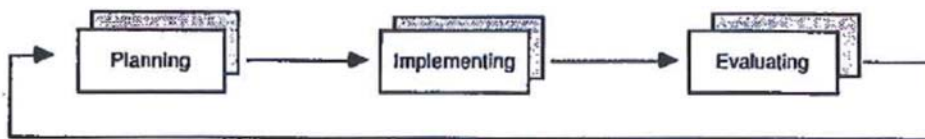

Planning: During the planning phase, the O&M activities to be performed are identified. The frequency of each O&M activity is determined.

Implementing: During the implementation phase, the resource requirements for performing the O&M activities are identified, and the O&M activities are performed. Systems are established for monitoring and tracking O&M activities and expenditures. Finally, information is collected and records are maintained.

Evaluating: During the evaluation phase, the O&M Program is assessed. The costs and benefits of the Program are identified. Program strengths and weaknesses are identified. The assessment information is used to plan new actions for improving the O&M Program.

D.2.2 ROLES AND RESPONSIBILITY

Roles and responsibilities for the activities of operation and maintenance of the Plant are assumed to be assigned by the Plant Owner(s) to the "Plant Management Structure" (PMS), structured taking into account the Owners needs, the two Plants operation needs, and the transboundary nature of the project.

It is here recalled that monitoring inspections are to be conducted by staff trained and certified as competent in dam safety inspections; maintenance operations shall be conducted by skilled staff, and monitoring data assessments and dam safety decisions are required from qualified engineers experienced in dam safety management.

D.2.3 PROCEDURE FOR CIVIL WORKS INSPECTIONS AND MONITORING

Inspections are foreseen to be carried out periodically on dam and other plant structures, in order to:

- 1) carry out a DAM SAFETY MONITORING

For the dam safety monitoring the inspections mainly consist in the periodic (typically on monthly basis) visual inspections and monitoring of the installed instruments, as described in the Operation manual of this report to which reference shall be made.

The goal of monitoring is to confirm ongoing safe performance or to identify changes from usual performance so that corrective actions can be taken before a catastrophic failure occurs. The management of emergency events is the object of the Emergency Preparedness Plan provided in separate dedicated part of the Dam Safety Plan.

- 2) Identify MAINTENANCE NEEDS

A Periodic visual inspection of all the main civil works and components of the Plant shall be conducted to check their status and identify maintenance needs. Such inspection can be combined with the one of point 1 above. The maintenance of the works will be conducted according to the results of these inspections.

Ordinary routine cleaning and maintenance activities are expected to be carried out systematically as far as needed to maintain in good and proper status the structures and their functionality.

Such routine maintenance is that which can typically be scheduled on the basis of time (weekly, monthly, etc) usage (Number of cycles hours of operation, etc) or observed condition from periodic visual inspections that identify dirty, small damages, excessive wear, corrosion etc.

Additional inspections should be carried out after significant events such as large floods or seismic events.

Specific items to be checked for each work or main component of the plant is provided in detailed lists in the following chapters of this report (each chapter dedicated to a specific work of the plant), with indication of minimum frequency required for the checks.

Operation and maintenance of all HSS and EM equipment pertinent to the dam structure will be detailed in relevant HSS and EM specific operation manuals. In the chapter D.3.14 "HYDRAULIC DEVICES AND MAIN CONTROL EQUIPMENT MAINTENANCE" at the end of this report it is however provided a table relevant to the basic guidelines for the proper inspection and testing of main hydraulic, mechanical and electrical devices which function is essential for the plant operation and dam safety. They shall be integrated with the dedicated detailed operation and maintenance manuals provided by the relevant suppliers.

Even with an effective preventative maintenance programme, there is a need to be prepared for emergency maintenance. This might include having critical spare parts, tools, equipment and trained competent staff ready in the event of an emergency.

A flowchart illustrating what to do if maintenance and / or dam safety issues are identified is included hereinafter. It can be further developed by the PMS according to his structure.

PROCESS DIAGRAM FOR MONTHLY DAM SAFETY AND MAINTENANCE INSPECTIONS

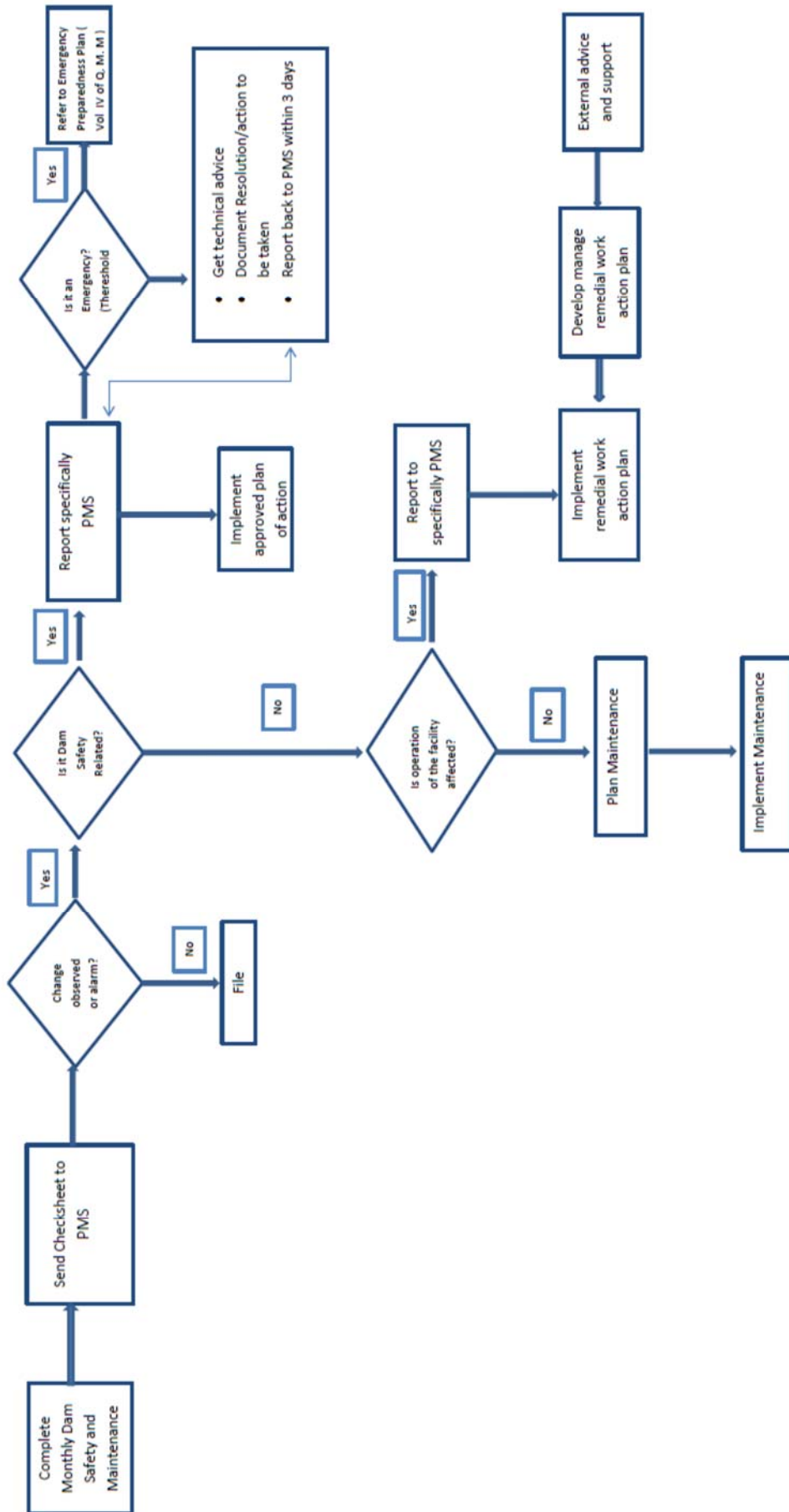

As far as the first box of the above diagram is concerned, it is to be clarified that the inspection program may not necessarily be implemented for all items on a monthly basis, but according to the required frequency that will be coordinated with the dam monitoring program implemented by the Employer taking into account the prescriptions presented in this report.

Following each inspection the inspection record should be assessed by a maintenance supervisor for organizing the appropriate maintenance activity.

Records of all maintenance activities are to be kept to provide a cross reference with the initial maintenance inspection recommendation. In the last chapter of this report a format for this task, in form of a typical CHECKLIST table, is provided.

Consequent to the inspection process described here above, the implementation of the maintenance activities or other activities linked to the dam safety shall follow the general criteria outlined in next paragraphs.

Any maintenance or repair or modification action consequent to an inspection shall be duly recorded, and archived for future use and reference, for each component of the project. The operator will organize an archive in digital and paper format, divided per parts of the work and for each part, as appropriate, for type of works (concrete, E&M equipment, HSS equipment, services, masonry, finishing, etc.)

This is a need for the benefit of anyone in the future will operate the plant, and for an easy identification of any (even minor) modification or intervention occurred during the lifespan of the plant, that allow right knowledge for subsequent maintenance and repair interventions.

Record, a part the check list compilation, can include according to the need dedicated sketches or drawings, or prescriptions/instruction of a certain element supplier, or any specific action for the subsequent monitoring and maintenance activity if some change in respect to the previous status of the works/equipment occurred.

D.2.4 GUIDELINES FOR MAINTENANCE ACTIVITIES

In each of the tables reported in following chapters, dedicated to the single civil works, there are provided also, in the last column "action-remarks", some indication of actions to be taken as consequence of observed anomalies.

As far as the DAM MAINTENANCE is concerned, the observations gathered during the inspection shall be acquired at the appropriate level according to the case, and the indication of actions to be taken integrated by the consultation of the specific maintenance manual of single components or products (if available) or by recurring to specialists or consultants if necessary for not ordinary maintenance need cases.

The ultimate aim of the maintenance activities is to ensure that the plant is capable of reliably performing its operational functions with no forced outages and at the minimum maintenance cost.

For issues concerning the dam (or other major works) safety and stability, and in general as far as the outcomes of the DAM SAFETY MONITORING inspections are concerned, the above mentioned indications shall be managed within the PMS by the personnel with adequate knowledge and decisional capacity as appropriate, on case by case basis.

Whenever deemed necessary the Designer or other specialist consultant shall be consulted.

In any case, if an emergency case has to be faced, the Emergency Preparedness Plan provided in dedicated part of the Dam Safety Plan shall be applied.

The following shall be considered in the organization/ implementation of any maintenance activity:

- it is necessary for operators to be familiar with the performance of this equipment, especially if it is otherwise infrequently used.
- The timing of plant maintenance is based on routine inspections, testing and plant history, so that maintenance work is planned and effected before the risk and consequences of failure, or declined performance become incompatible with the availability, reliability and ratings required for operation.
- Essentially the maintenance regime is a combination of preventive and predictive maintenance, which minimizes the maintenance cost and the plant malfunctions.
- The plant manufacturer's maintenance instructions and recommended intervals form the initial basis for scheduling the extent and frequency of maintenance work. However extent and frequency are subject to change in the light of in service performance.
- In particular the mechanical and electrical equipment require appropriate maintenance and testing. Gates, lifting equipment and power supplies should be continuously maintained during frequent inspections and minor maintenance works, as illustrated in the last chapters of this report and in the relevant manuals of the Plant Contractor.

D.2.5 FIVE-YEARLY DAM SAFETY VERIFICATION

Five-yearly Dam Safety Verifications should include the hydraulic structure equipment essential for operation, namely all gate structures and hydraulic devices as listed in the chapter D.3.14 "HYDRAULIC DEVICES AND MAIN CONTROL EQUIPMENT MAINTENANCE".

These comprehensive inspections should be carried out by an independent expert examination team, comprising as a minimum a civil, an electrical and a mechanical reviewer, and include the following tasks:

- Comprehensive site inspection and witnessing of gate testing;
- Review of dam and gate structure design and potential failure modes;
- Review of dam monitoring data;
- Review of operations and maintenance issues and records;
- Review of emergency preparedness procedures and documentation;
- Review of personnel training record and competencies certification.

D.3 MAINTENANCE

D.3.1 RESERVOIR MAINTENANCE

Here below are resumed the principal aspects and actions required for the maintenance plan relevant to the **RESERVOIR**. Reservoir level monitoring and the monitoring of all topographic instruments are not included, being described in other section this report.

What indicated in the table above is indicative and preliminary and needs to be detailed and updated according to the detailed design and construction process, when it will be also available a list of detailed design or as built drawings to which reference be made for each item of the table.

Pr	Civil Feature	Description of check of performance indicators	frequency	Maintenance Actions - Remarks
1	Reservoir shoreline	Clear and evident signals marking the shoreline, all around the reservoir perimeter.	First two years: 6 months. in case of absence of problems, from the third year: every 5 years , or in case of major flood or earthquake events.	Visual inspection of reservoir shoreline marks, all around the reservoir perimeter. If it is observed a defect in the proper and adequate identification of the shoreline for the main operation and flood reservoir levels, new marking or refurbishing of the existing one shall be carried out. In particular this activity is required in habituated lands areas.
2	Reservoir Slopes movements	Signal of movement or slides of reservoir slopes, all around the reservoir perimeter.	First two years: 6 months. in case of absence of problems, from the third year: every 5 years , or in case of major flood or earthquake events.	Visual inspection of reservoir slopes, all around the reservoir perimeter. In the dam proximity, topographic check with existing benchmarks can be implemented (see instrument monitoring system). If sliding phenomena or cracks opening on the ground are observed, they shall be monitored and, if necessary, slope stabilization measures considered (see NOTES)
3	Reservoir Slopes movements near dam	Signal of movement or slides of reservoir slopes in the vicinity of the dam.	First two years: 1 month. in case of absence of problems, from the third year: every 1 year , or in case of major flood or earthquake events.	Control of fix benchmarks coordinates, with a moveable sighting station and a theodolite or with a GPS. To be compared with the given coordinates given during construction. (see also instrument monitoring system). Measures shall be collected and filed in tabular (spreadsheets) and graphic format. Anomalies in trend or significant displacement and movements registered shall be reported. If necessary, slope stabilization measures reconsidered (see NOTES)
4	Floating Barrier (if present)	Damages of buoys. Rusting or damage of anchorage and steel components.	every 5 years, or in case of major flood events.	Dismantling of the floating barrier, and repair/substitution of damaged parts. Activity to be carried out with skilled people. Barge or boat required for re-installation at the end of the reparation process. Minor repairs can be conducted, if possible and convenient, without dismantling the floating barrier, directly from a boat within the reservoir.
5	Floating Barrier (if present)	Accumulation of debris or other floating elements.	First year after impounding completion: 3 months. Then every year, at the end of rainy season, or in case of major flood events.	cleaning of floating barrier by the trunks, debris or other floating elements that could be accumulate with the time. By means of small boats and racking devices accessing from dam crest or reservoir shoreline near dam (dam abutments yards)
6	Reservoir Water Cleaning	In the proximity of the spillway gates, along the dam crest, presence of trunks, debris or other floating elements that could be accumulate with the time.	First year after impounding completion: 2 months. from the following years: every year, at the end of rainy season, or in case of major flood events.	cleaning of superficial waters by the trunks, debris or other floating elements that could be accumulate with the time. By means of small boats and racking devices accessing from dam crest or reservoir shoreline near dam (dam abutments yards). Do not throw any trunk or debris through the spillway.
NOTES:				
In case of results or controls evidenced anomalies or problems, the measures shall be repeated for check, and then, if confirmed, the Plant Management Structure direction shall be immediately informed and Direction involved in the dam safety consulted. According to the case the designer or a specialist consultant shall be consulted. All operations shall be done by skilled personnel, instructed and authorised by the Plant Owner(s) for the operation required.				

Table 12 - Principal aspects and actions required for the Reservoir maintenance plan

D.3.2 DAM CIVIL WORKS MAINTENANCE

Here below are resumed the guidelines and actions required for the maintenance plan relevant to the **DAM**.

Monitoring of all instruments inside the dam are integral part of the dam monitoring and maintenance system, but they not included here, being already described in other section of the report to which reference shall be made.

The following table is mainly focused on the civil works.

What follows is indicative and preliminary, to be detailed and updated according to the detailed design and construction process, when it will be also available a list of detailed design or as built drawings to which reference be made for each item of the table.

Pr	Civil Feature	Description of check of performance indicators	frequency	Maintenance Actions - Remarks
1	Instruments monitoring	<p>The dam instruments monitoring is described in other section of this report, to which reference shall be made.</p> <p>In addition ordinary inspection and maintenance of the instruments (including the meteo station) is required:</p> <p>check of proper functioning of each installed instruments (lubrication, cleaning, greasing, software updating, connections, data acquisition and transmission)</p>	1 month	<p>Ordinary maintenance (lubrication, cleaning, greasing, software updating, check of connections) to be carried out according to the relevant maintenance manuals provided with each instrument by the supplier.</p> <p>Defect, malfunction or rupture of any instrument shall be recorded and appropriate action taken (see NOTES).</p>
2	Dam drain system pumps control	<p>Check of proper functioning of the pumps located in the downstream pits (**)</p> <p>check of proper functioning of pumps (lubrication, cleaning, power and control cables, start-stop signal system functions) and cleanliness of the output pipes</p>	<p style="text-align: center;">First two years: 1 month.</p> <p>in case of absence of problems, from the third year: every six months, or in case of major flood or earthquake events.</p>	<p>At each control of the pumps an operation of start and stop of each pump shall be done. The cleanliness of the output pipes shall be checked and eventually restored. (**)</p> <p>A part the ordinary cleaning, in case of any problem observed, follow the pumps maintenance manuals.</p> <p>Defect, malfunction or rupture of any pump shall be recorded and appropriate action urgently taken (see NOTES).</p>
3	Galleries drain ditches Cleaning	<p>The drain ditches shall be checked to be free from obstructions or mud or debris that can be obstacle to the flowing of the water. (**)</p> <p>This check applies also for pits at the side of each downstream entrance to the galleries, and for the pumps pits</p>	<p style="text-align: center;">First year after impounding completion: 2 months.</p> <p style="text-align: center;">from the following years: every year.</p>	<p>The drain ditches shall be always clean and free from obstructions or mud or debris that can be obstacle to the flowing of the water. As far as necessary they shall be cleaned by hand or mechanical tools (the same for the pits). (**)</p>
4	Drains	<p>The drains inside the dam shall be checked to be free from obstructions or calcifications that can be obstacle to the flowing of the water.</p>	Inspection and single drain maintenance: every year.	<p>The single drains obstructed shall be cleaned by mechanical means or high pressure water jets.</p>

		A systematic periodic cleaning is suggested	Systematic cleaning: 10 years	Long term periodic washing of all the drain is suggested to contrast progressive expected occlusion.
5	Illumination	Visual control and inspection of lamps and cables functioning for both external (light posts) and internal (lamps inside galleries and control buildings) illumination systems	1 year	Ordinary maintenance of all illumination system and electrical parts shall be done, as needed.
6	Concrete surfaces	<p>Visual control and inspection of the status of all concrete surfaces. In particular it shall be checked:</p> <ul style="list-style-type: none"> - Presence of cracks - Water percolations - Possible exposed reinforcement <p>In particular, as far as dam is concerned, this check shall be carried out inside the galleries, on dam downstream face and, as far as possible on the upstream face). Special attention shall be paid to the crest spillway surface.</p> <p>Analogue prescription applies for all the civil structures of the project, not only to the dam.</p>	<p>1 month.</p> <p>In any case always after exceptional flood or earthquake event.</p>	<p>Observed anomalies, if any shall be recorded, monitored and appropriate actions taken (see NOTES).</p> <p>If it is ascertained, by the Plant Management direction, that the defects registered do not involve problems for the stability and safety of the structure, ordinary maintenance activities can be carried out to repair such defect. On the contrary case, actions shall be defined on case by case basis consulting a specialist.</p> <p>Whenever reinforcement appears exposed, following measures shall be taken:</p> <ul style="list-style-type: none"> - concrete shall be locally demolished, - reinforcement brushed and cleaned from oxidations and dusts, - reinforcement protected against corrosion, - completely saturate with water the zone to be reconstructed, waiting evaporation of water in excess, -prepare a grout with water+ high resistance cement+ selected inert+ synthetic fibres admixtures gently mixing to incorporate air also, - apply no shrinkage grout, for thickness of no more than 3cm per layer, than finishing of the surface.
7	Control building, access buildings civil works finishing	<p>Visual control and inspection of the status of all concrete or metal surfaces, structures and finishing pertaining to the buildings and civil works structures. In particular it shall be checked:</p> <ul style="list-style-type: none"> - Presence of cracks in the concrete - Water percolations - Possible exposed reinforcement - leaks from the roofs - finishing deterioration - paintings deterioration - damages to tiles, if present - functioning of doors and windows - rusting of metal structures - status of steel girders, guardrails, parapets, lamp posts, stairs, ladders - status of the gutters and drains, that shall be free from obstructions. <p>For the dam this check includes the Dam Control Building, Diesel Generator</p>	<p>6 months</p> <p>In any case always after exceptional rainstorm or earthquake event.</p>	<p>Ordinary maintenance of all concrete surfaces, metal works and finishing shall be done, as needed. Steel girders must be repainted when rust will appear.</p> <p>Repair of exposed concrete can be conducted as described at point 6 above).</p> <p>If it is ascertained, by the Plant Management direction, that the defects registered involve problems for the stability and safety of the structure, actions shall be defined on case by case basis consulting a specialist.</p>

		Building, Cable shaft access Room on dam crest, Spillway gates servomotors rooms on dam piers, and other access structures also on dam crest). Similar prescription applies for all the civil structures of the project.		
8	Lift inside cable duct (if present)	Check of lift functioning. Check of proper lubrication of the mechanism, according to the supplier maintenance manual	1 year In any case always after exceptional earthquake event.	Ordinary maintenance according to the supplier maintenance manual. Repair in case of rupture, as far as to maintain it available for access inside the dam at any moment.
9	Lifting structure for access/repairs of pumps, MLO gates, and ancillary works on dam downstream face	Visual control of the status of metal structure and its anchorage Check of functioning of lifting device.	1 year, and in any case always after exceptional earthquake event. Every 10 years the test of lifting device shall be done with a load equivalent to the pump weight.	Ordinary maintenance of metal works and finishing shall be done, as needed. Any damage to the lifting device shall be reported to the Plant Management direction for action of repair.
10	Fences and Gates	Visual control and inspection of the status of fences and gates In particular it shall be checked: - rusting of metal structures - painting deteriorations - damages to fences or their anchorage - functioning of locking of galleries doors - functioning and status of restricted areas gates	1 year In any case always after exceptional rainstorm or earthquake event.	Ordinary maintenance of all metal works and finishing shall be done, as needed, to maintain them and to allow full access to authorized people inside the restricted areas.
11	Dam access roads	The efficiency and cleaning of dam access roads (including the dam crest road) and their drain ditches shall be checked.	Six months In any case always after exceptional rainstorm or earthquake event.	Ordinary maintenance and cleaning of all roads pavement and deep cleaning of all the drain system is required to maintain the functionality of the roads, metal works and finishing shall be done. Local repair of any damages is required, as needed.
12	Protection of the slopes at yards and access roads	It shall be checked the efficiency and status of the support and protection system of the slopes around the dam (in particular the excavated slopes around the abutments yard and of the access roads). In particular it shall be checked: - Defective anchors - Break of rockfall protection nets or barriers - Filling of debris of rockfall protection nets or barriers (if present) - cracks or damages to the shotcrete - Important or extended leaks from drains. - sing of movements of the excavated front - rockfalling or slides events.	Six months In any case always after exceptional rainstorm or earthquake event. Periodic cleaning of the rockfall protection nets or barriers required.	Any observed damage or anomaly shall be measured, documented and reported in all details. In case of instable wedges to be scaled, this shall be done by skilled people. Extended areas of damaged shotcrete shall be cleaned and repaired. Damaged bolts shall be replaced. In case of continuous important or extended flow of water is observed coming out from drainage holes, the flow shall be monitored (quantifying the flow and reporting it on a spreadsheet). Than a specialist designer shall be consulted. Defect, malfunction or rupture of any anchoring or protection system, as well as any sign of excavated front movement, shall be recorded and appropriate action taken (see NOTES).

				Periodic cleaning of the rockfall protection nets or barriers (where present) required.
13	Dam crest road bridges beams and spillway main crane railways beams.	All steel parts (if any) of the main deck structure shall be periodically inspected by skilled personnel. Special attention shall be paid in checking the bolted and welded junctions, and the integrity of the superstructures as well as presence of rust or paint damages.	First visit 1 year after construction than frequency of controls to be defined, in any case no more than every 5 years	Eventual anomalies or damages in steel structure and junctions shall be documented and reported in all details, where possible quantifying the extension of the damage in a dedicated spreadsheet, in relevant drawings and by a set of photos. Than appropriate actions taken (see NOTES).
14	Dam crest shock absorbers (if present)	<ol style="list-style-type: none"> 1. Visual control of the general status of the device. 2. Control on the compatibility of the stroke or the rotations occurred with the ones foreseen by the device. 3. Control of the bolts tightening and of the connections. 4. Control of any oil leakage. 5. Check of external cleaning and possible presence of rust. 6. Control that the sliding systems are not seized-up or ruined 7. Verify the integrity and efficiency of stem protection. 	First control (only check indicators 1,2 and 3) after six months from the installation. Then full check (7 check indicators) every 2 years or in case of seismic event.	<p>Eliminate possible dust and/or encrustation. Remove and restore possible rusted points.</p> <p>Contact the supplying firm in case of:</p> <ul style="list-style-type: none"> - Oil leakage - the sliding systems are not seized-up or are ruined - presence of rust in inaccessible zones. <p>Every 10 years it is suitable a verification at the workshop, by removing a number equal to 5% of the devices installed, with a minimum of one.</p>
15	Crest road bridges bearings and spillway main crane railways beams bearings (as far as present and applicable) periodic check	<p>Bearings shall be checked periodically, in order to verify:</p> <ul style="list-style-type: none"> - Correct positioning of the structures and status of bearing bed and anchorage. - Absence of movement or anomalous deformations <p>Capacity of the bearing to assure the consented movement of the structure, verifying the displacement of the bearings mobile parts during different seasons.</p> <ul style="list-style-type: none"> - Absence of ruptures - The good conservation of the devices foreseen against corrosion and against dust - The uniformity of the contact, as foreseen in the project. - The maintain of the designed geometry (parallelism and planarity of contact surfaces) - Eventual anomalies or cracks in structures near the bearings, that could be induced by a problem to the bearing. 	2 years	<p>Eventual anomalies in the bearings or cracks in the concrete structure near the bearings shall be monitored, documented and reported in all details, where possible quantifying the extension of the damage in a dedicated spreadsheet, in relevant drawings and by a set of photos. Than appropriate actions taken (see NOTES)</p> <p>Bearings must be checked and, when necessary replaced with new ones. For frequency of controls, maintenance operations and all details for replacing see relevant maintenance manual provided by the bearing supplier.</p> <p>For maintenance or replacing of part or all the bearing, the relevant bridge deck shall be lifted for this operation.</p> <p>The jacks for lifting operation shall be inserted in dedicated holes and shall have the design load and characteristics given in design drawings.</p>

Table 13 - Principal aspects and actions required for the Dam civil works maintenance plan

(**) The following shall be considered in organizing such maintenance operation:

- Consideration should be given to monitoring the depth and type of sediment at the gallery weirs before each gutter cleaning, rather than just removing and discarding it. This should be done on a regularly scheduled basis (say every 2 weeks during reservoir impounding).

Samples of the sediment should be analysed on occasion for grain size, plasticity, pH, and composition. This information can be very useful if any piping or erosion starts in any of the foundation drains. The pH can be used to indicate if some of the seepage is coming from internal drainage of the dam itself, picking up calcium hydroxide (basic) on the way. Consideration should also be given to using a hand held "pistol" type temperature indicator to check the temperature of water coming from foundation drains. It is recommended to also keep simple method of documentation for easier consultation, just writing the date and temperature on the wall next to the drain with a pencil. If the temperature changes, the date and new temperature should be noted. This could, for example, indicate that water from the reservoir is migrating to a hot spring area if the temperature of water from those drains decreases as the reservoir is raised.

- Consideration should be given to recording the volume of water pumped per week or month from the gallery sumps. Seepage flows are measured using weirs in the gallery gutters, but the pump records can be used as a check or verification.

D.3.3 MIDDLE OUTLETS MAINTENANCE

Here below are resumed the guidelines and actions required for the maintenance plan relevant to the **MIDDLE OUTLETS**.

As far as the prescriptions for the civil works regarding the check of concrete surfaces, of the reinforced concrete structures and of the status of the building and their finishing, reference should be made to the prescriptions provided in Pr.6 "Concrete surfaces" and Pr.7 "Control building, access buildings civil works and dam crest finishing " in table reported in chapter D.3.2, which are not reported again in the following table.

Pr	Civil Feature	Description of check of performance indicators	frequency	Maintenance Actions - Remarks
1	Middle Level Outlets Drains	<p>Any specific drains running around the middle outlet steel lining, exit in nearest the dam gallery, in correspondence of the two middle outlets.</p> <p>The water venues through these drains shall be monitored as prescribed and done for the other drains of the dam.</p> <p>The drains shall be checked to be free from obstructions or calcifications that can be obstacle to the flowing of the water.</p>	<p>Inspection and single drain maintenance: every year.</p> <p>Systematic cleaning: 10 years</p>	<p>Anomalous records shall be reported to PMS.</p> <p>The single drains obstructed shall be cleaned by mechanical means or high pressure water jets.</p> <p>Long term periodic washing of all the drain is suggested to contrast progressive expected occlusion.</p>
2	Gates maintenance platform	<p>Maintenance platforms and devices envisaged on the dam, outdoor, shall be checked.</p> <p>Check of good status of the steel, check of possible presence of rusting is required. Periodic test of platform opening and closing mechanism (as far as present and applicable) is required.</p>	Every year.	<p>The platform/device shall be maintained efficient by means of ordinary maintenance activity (including mechanism greasing as necessary) and periodic testing of functioning.</p>
3	Steel lining	<p>Check of alignment, status of weldings and joints, cavitation effects</p>	Every 5 years, or in any case of emergency or prolonged use of MLO.	<p>Emptying the MLO conduit by closing the upstream bulkhead is required for this operation. Any anomaly shall be duly recorded and signalled (see NOTES).</p>
4	Recess for d/s gate servomotors pumps	<p>From dam d/s berm it is possible to get access to the chamber housing the servomotors for d/s gate operation.</p> <p>Check of good status and functionality of the chambers structure, gates, drains and relevant accessibility is required. Check shall be extended to the cables corridors.</p>	Every year.	<p>Servomotors shall be used and maintained as prescribed by the specific gates operation and maintenance manual.</p> <p>Accessibility to their chambers shall be maintained efficient by means of ordinary maintenance activity.</p>
5	Sand disposal valves, by-pass valves, other auxiliary hydraulic devices.	<p>Check of good status of the valves and hydraulic devices, of their functioning and of the accessibility to their chambers is required.</p>	Every year.	<p>Valves shall be used, during or after any use of middle outlet, as prescribed by the specific gates operation and maintenance manual.</p> <p>Accessibility and functioning of the valves shall be maintained efficient by means of ordinary maintenance activity and periodic testing of the valves functioning.</p>
<p>NOTES:</p> <p>1) In case of results or controls evidenced anomalies or problems, the measures shall be repeated for check, and then, if confirmed, the Plant Management direction shall be immediately informed and Direction involved in the dam safety consulted. According to the case the designer or a specialist consultant shall be consulted.</p> <p>2) All operations shall be done by skilled personnel, instructed and authorised by the Plant owner for the operation required.</p> <p>3) For check of concrete surfaces and of the status of the building and their finishing, the prescriptions provided in Pr.6 and Pr.7 in table reported in chapter D.3.2 shall be applied.</p>				

Table 14 - Principal aspects and actions required for the Middle Outlets maintenance plan

D.3.4 SPILLWAY MAINTENANCE

Here below are resumed the guidelines and actions required for the maintenance plan relevant to the **SPILLWAY**.

The following table is mainly focused on the civil works (Gates and other EM and HSS equipment Operation and Maintenance manuals are issued separately).

As far as the prescriptions for the civil works regarding the check of concrete surfaces, of the reinforced concrete structures and of the status of the building and their finishing, reference should be made to the prescriptions provided in Pr.6 "Concrete surfaces" and Pr.7 "Control building, access buildings civil works and dam crest finishing " in table reported in chapter D.3.2, which are not reported again in the following table.

The prescriptions about civil work regarding the beams, bearings and shock transmitter units possibly present on the top of the spillway piers are provided in Pr.13 "Dam crest shock absorbers", Pr.14 "Crest road bridges bearings and spillway main crane railways beams bearings periodic check" and Pr.15 "Dam crest road bridges steel beams and spillway main crane railways beams" in table reported in chapter D.3.2, to which reference shall be made (they are not reported again here).

Pr	Civil Feature	Description of check of performance indicators	frequency	Maintenance Actions - Remarks
1	Spillway radial gates tendons	<p>Spillway radial gates piers have tendons in their body. They do not require in principle any special maintenance, being fully greased and vipped as protection against corrosion and inserted in a sleeve pipe fully embedded in concrete. However the space between tendon and sleeve pipe is not grout injected, and this allows possible intervention for possible re-tensioning operations.</p> <p>It is therefore recommended, within the ordinary inspections to the civil works, to carry out specific visual check of:</p> <ul style="list-style-type: none"> - possible presence of cracks or sign of deformation that might appear on the piers. - Misalignment of the radial gate in respect to its lateral guides. - Malfunctioning on opening or closure operation of the radial gate. 	<p>Ordinary inspections on monthly basis, or after any relevant flood event.</p> <p>Direct measures of tendons tension is recommended to be carried out 1 year after initial pulling, then 5 years after initial pulling, then every 10 years.</p> <p>In any case after any flood or earthquake event.</p>	<p>In case signs of piers deformation are detected or possible gates malfunctioning indicating possible tendons detensioning, they shall be duly reported to PMS and, upon consultation of expert, possible intervention of re-tensioning of one or more tendons can be organized and implemented (see NOTES).</p> <p>In such case the following aspects are to be considered: Wether access to the tendons heads is possible from a dedicated shaft located inside the pier The head of the tendons are typically protected with tixotropic gel (that shall be restored at the end of any intervention). Tensioning shall be carried out by adequate jack controlled by a standard multi-cables control system. A regulating ring nut can be foreseen on the head of the tendon anchor, allowing an easy intervention with the jack</p>

				<p>for tensioning and de-tensioning operation.</p> <p>This special maintenance operation, as well as other possible ordinary maintenance operations (lubrication, cleaning, greasing, software updating, check of connections) are to be carried out according to the relevant maintenance manuals provided by the tendons supplier.</p>
2	Spillway drains	The drains pipes of the drain system laying under the spillway chutes shall be checked to be free from obstructions or calcifications that can be obstacle to the flowing of the water.	<p>Inspection and single drain maintenance: every year or after important or prolonged flows passing through the spillway.</p> <p>Systematic cleaning: 10 years</p>	<p>The single drains obstructed shall be cleaned by mechanical means or high pressure water jets.</p> <p>Long term periodic washing of all the drain is suggested possible occlusion.</p>
3	Lateral walls ceiling and aerators ducts	Visual check of good status and possible movement of the structures	Every 5 years or after important or prolonged flows passing through the spillway.	<p>Damaged or moved elements shall be replaced and/or properly fixed.</p> <p>Aerator conduits if obstructed or damaged shall be cleaned or repaired as needed.</p>
4	Chute finishing	<p>Visual check of good status of the spillway chutes slabs, including check of:</p> <ul style="list-style-type: none"> • Presence of fissures or cracks; • Detachment of finishing concrete layer at the contact with lateral walls and a the chute slabs extremities • Damages (erosion, cavitation effects) on concrete surfaces 	For first two years every year, then every 5 years, or in any case after important or prolonged flows passing through the spillway.	<p>Any anomaly shall be duly recorded and signalled, possibly associated with measures of spillway discharge, meteo conditions, spillway drains outflows (see NOTES). Repairing intervention, if needed shall be properly designed (for instance making use of suitable products to repair damages induced by water passing at very high speed). and conducted by skilled people, in safe conditions.</p>
5	Radial gates lateral sealing	Visual check of possible leaks on the radial gates sides when gates are closed and reservoir is at maximum operating level.	For first two years every year, then every 5 years, or in after important or prolonged flows through the spillway.	<p>Any anomaly shall be duly recorded and signalled (see NOTES). Deeper checks (such piers alignment, water discharge and possible dependence from meteo conditions) to be prescribed on case by case basis.</p>
6	Piers upstream face, stoplogs grooves and chute waterways	<p>Visual check of presence of trunks and debris transported by the water near the gates and stoplogs grooves when gates are closed.</p> <p>Visual check of possible damages to the concrete or presence of trunks along the chutes after flood passage through the spillway.</p>	Every 5 years, or in any case after important or prolonged flows passing through the spillway.	<p>Any anomaly shall be duly recorded and signalled (see NOTES). Ordinary maintenance of civil works is required. Debris or trunks invading the stoplogs grooves or the chutes shall be immediately removed.</p>

7	Piers joints.	Visual check of presence of infilling or debris within the joints. Upstream of the water-stop alignment, the water shall be free to enter within the space of the vertical joints.	Every year, or in any case after important or prolonged flows passing through the spillway.	Any anomaly shall be duly recorded and signalled (see NOTES). Ordinary maintenance of civil works is required. Debris or trunks obstructing the joints upstream of the water-stops alignment shall be cleaned/removed.
8	Radial gates servomotors pumps rooms	From dam crest it is possible to get access to the chambers housing the servomotors for radial gates operation. It is required a periodic visual check of the good status and functionality of the chambers and cable bridge structures and their accessibility.	Every year.	Servomotors shall be used and maintained as prescribed by the specific gates operation and maintenance manual. Accessibility to their chambers and to the cable bridge shall be maintained efficient by means of ordinary maintenance activity.

NOTES:

- 1) In case of results or controls evidenced anomalies or problems, the measures shall be repeated for check, and then, if confirmed, the Plant Management direction shall be immediately informed and Direction involved in the dam safety consulted. According to the case the designer or a specialist consultant shall be consulted.
- 2) All operations shall be done by skilled personnel, instructed and authorised by the Plant owner for the operation required.
- 3) For check of concrete surfaces and of the status of the building and their finishing, the prescriptions provided in Pr.6 "Concrete surfaces" and Pr.7 "Control building, access buildings civil works and dam crest finishing" in table reported in chapter D.3.2 shall be applied.
- 4) For shock transmitters units and bearings on beams located on the top of the spillway piers, see specific prescriptions provided in table reported in chapter D.3.2.

Table 15 - Principal aspects and actions required for the Spillway maintenance plan

D.3.5 PLUNGE POOL MAINTENANCE

The pool is designed to safely withstand floods events.

The pool, and the concrete structures protecting the dam downstream toe are conceived as sacrificial barriers and are not meant to be fully stable and not subject to erosion or scouring in the long term. They are conceived as first line of defense to protect from scouring the permanent works such the dam and the power house.

A part the ordinary maintenance of the abutments slope stability supports, important to guarantee in the long term the accessibility to the dam (see prescriptions on relevant DAM chapter), the plunge pool area doesn't require specific operation and maintenance actions.

At this level of the design, no specific actions are therefore foreseen in the submerged portion of the pool during the normal operation of the plant.

Some scouring is expected to occur within the pool, and material (rock blocks) to remain in its bottom.

It has to be reminded that most of the pool will be permanently under water, and inspection and possible maintenance actions implies the use of a barge or its dewatering by means of pumps. This means that such actions shall be programmed and planned in advance and in any case shall be carried out only when strictly necessary.

It is however recommended to check its behavior and stability in the case of specific exceptional flood or extraordinary spillway discharge event, especially as far as the aspects affecting the proper functioning of the permanent structures of the plant (Power House and Dam). Such checks are described in the following table.

Pr	Civil Feature	Description of check of performance indicators	frequency	Maintenance Actions - Remarks
1	Slopes stability	<p>Visual check of:</p> <ul style="list-style-type: none"> • status of shotcrete, bolts, drainages and drain ditches foreseen on benches • potential instable wedges. • Signal of movement or slides of slopes. • Debris accumulation on benches. • Check of possible crack openings or fissures or deterioration of concrete surfaces. <p>The visual check will be ordinarily conducted on the accessible portions of the excavations (upper portion of the excavated fronts), as far as possible extending the observation to the submerged parts (for instance during dry season or possible stop of the plant).</p>	<p>After first spillway operation. After first Middle Outlets operation. Then yearly, preferably at the end of rainy season. Additionally in case of an exceptional flood event.</p>	<p>Any anomaly shall be duly recorded and signalled. Deeper checks (and check of possible dependence from meteo conditions) to be prescribed on case by case basis. If sliding phenomena or cracks opening are observed, they shall be monitored and, if necessary, slope stabilization measures reconsidered (see NOTES). Accumulation of debris on accessible benches shall be removed.</p>
2	Upstream concrete structures (dam d/s toe protection structures)	<p>Visual control and inspection of all concrete surface, as far as visible.</p>	<p>After first spillway operation. After first Middle Outlets operation. Then only in case of an exceptional flood event.</p>	<p>Any anomaly shall be duly recorded and signalled, possibly associated with measures of spillway or MLO discharge and meteo conditions (see NOTES). Repairing intervention, if needed shall be properly designed and conducted by skilled people, in safe conditions.</p>
3	Excavation profile	<p>It shall be checked the profile of the pool bottom, with the aim to check if there is no risk of damages for the permanent civil works (PH and DAM) and that it is not compromised the plant energy production. This check can be done firstly visually, checking if there is accumulation of eroded material out of the pool. In this case, and in any case on 10 years period basis, a bathymetric survey is required.</p>	<p>After first spillway operation. After first Middle Outlets operation. In any case of an exceptional flood event (Q>6500m³/s). Recommended in any case every 5-10 years (depending on Spillway and middle outlets use).</p>	<p>Any anomaly shall be duly recorded and signalled, possibly associated with measures of spillway or MLO discharge and meteo conditions (see NOTES). Repairing intervention, if needed shall be properly designed and conducted by skilled people, in safe conditions.</p>

NOTES:

- 1) In case of results or controls evidenced anomalies or problems, the measures shall be repeated for check, and then, if confirmed, the Plant Management direction shall be immediately informed and Direction involved in the dam safety consulted. According to the case the designer or a specialist consultant shall be consulted.
- 2) All operations shall be done by skilled personnel, instructed and authorised by the Plant owner for the operation required.
- 3) For check of concrete surfaces and of the status of the building and their finishing, the prescriptions provided in Pr.6 "Concrete surfaces" and Pr.7 "Control building, access buildings civil works and dam crest finishing" in table reported in chapter D.3.2 shall be applied.

Table 16 - Principal aspects and actions required for the Plunge Pool maintenance plan

For the check of concrete surfaces reference should be made to the prescriptions provided in Pr.6 "Concrete surfaces" and Pr.7 "Control building, access buildings civil works and dam crest finishing " in table reported in chapter D.3.2, which are not reported again in the previous table.

D.3.6 INTAKE GATES STRUCTURE and relevant upper yard MAINTENANCE

What follows is referred to one structure but applies for both left and right Power Waterways.

As far as the prescriptions for the civil works regarding the check of concrete surfaces, of the reinforced concrete structures and of the status of the building and their finishing, reference should be made to the prescriptions provided in Pr.6 "Concrete surfaces" and Pr.7 "Control building, access buildings civil works and dam crest finishing " in table reported in chapter D.3.2, which are not reported again in the following table.

Pr	Civil Feature	Description of check of performance indicators	frequency	Maintenance Actions - Remarks
1	Yard slopes protection devices	Visual check of the visible (not submerged) portions, in particular check of: <ul style="list-style-type: none"> • status of shotcrete, bolts, drainages and drain ditches foreseen on benches • potential instable wedges. • Signal of movement or slides of slopes. • Debris accumulation on benches. • Check of possible crack openings or fissures or deterioration of concrete surfaces. In case of continuous flow of water is observed coming out from drainage holes, the flow shall be monitored (quantifying the flow and reporting it on a spreadsheet).	After first Power waterways operation. Then yearly, preferably at the end of rainy season. Additionally in case of an exceptional heavy rain or earthquake event , or Power Waterways dewatering.	Any anomaly shall be duly recorded and signalled. Deeper checks (and check of possible dependence from meteo conditions) to be prescribed on case by case basis. If sliding phenomena or cracks opening are observed, they shall be monitored and, if necessary, slope stabilization measures reconsidered (see NOTES). In case of instable wedges to be scaled, the scaling shall be done by skilled people. Extended areas of damaged shotcrete shall be cleaned and repaired. Damaged bolts shall be replaced. Accumulation of debris on accessible benches or any obstruction of drain ditches or pipes shall be removed. Than a specialist designer shall be consulted. Ordinary maintenance and cleaning of the drain ditches, as needed.
2	Finishing of the tunnel lining downstream of the gates	Visual check of good status of the concrete surface, including check of: <ul style="list-style-type: none"> • Presence of fissures or cracks; • Detachment of finishing concrete layer at the contact with lateral walls and along the transition downstream and upstream of the gates. • Damages (erosion, cavitation effects) on concrete surfaces or near joints 	In case of Power Waterways dewatering.	Any anomaly shall be duly recorded and signalled, possibly associated with measures of spillway or MLO discharge and meteo conditions (see NOTES). Repairing intervention, if needed (for instance making use of suitable products to repair damages induced by water passing at very high speed) shall be properly designed and conducted by skilled people, in safe conditions.

NOTES:

- 1) In case of results or controls evidenced anomalies or problems, the measures shall be repeated for check, and then, if confirmed, the Plant Management direction shall be immediately informed and Direction involved in the dam safety consulted. According to the case the designer or a specialist consultant shall be consulted.
- 2) All operations shall be done by skilled personnel, instructed and authorised by the Plant owner for the operation required.
- 3) For check of concrete surfaces and of the status of the building and their finishing, the prescriptions provided in Pr.6 "Concrete surfaces" and Pr.7 "Control building, access buildings civil works and dam crest finishing" in table reported in chapter D.3.2 shall be applied.

Table 17 - Principal aspects and actions required for the Intake gate structure maintenance plan

The above applies for gate shafts concrete structures (yard, exposed structure and upper control building). Other prescriptions for maintenance inspection and operation of such structures are provided in the table here below. For the maintenance of gates and all EM and HSS equipment, see relevant section.

Of course, for this structure, the portion that during normal operation of the plant is under water can be inspected only in the case of exceptional dewatering of the Power Waterways, that, unless for other exceptional needs, is recommended to be carried out every 10 years.

During first impounding it is recommended to either clean the trash racks when water is raising at intake towers levels and trunks might obstruct them, or protect them by floating barrier temporary installed in front of them.

D.3.7 POWER TUNNEL MAINTENANCE

What follows is referred to one structure but applies for both left and right Power Waterways.

During the operation of the plant the tunnel is not accessible. No special operation and maintenance needs are foreseen for the civil works of the tunnel.

Power waterways can be inspected by dewatering the tunnels (by closing the intake gates).

The power waterways dewatering (and subsequent filling) procedures are described in relevant paragraph of operation manual section, to which reference is made.

Such operation can be decided in case of need of inspection of the tunnel (for instance decided in case of important leakages detected in the drain, or in any case recommended after 10 years of tunnels operation), instructed and authorized by the Plant Owner consulted by design specialist.

The inspection of the tunnel, shall be programmed in advance to allow to manage the consequences of a long period of plant stop and long period of water discharge through the spillway/middle outlet.

It shall be carried out by skilled personnel only, **instructed and authorized by the Plant owner for the operation required, consulting a design specialist.**

In case of such extraordinary event of inspection, the following operations can be envisaged as far as the civil works are concerned:

Pr	Civil Feature	Description of check of performance indicators	frequency	Maintenance Actions - Remarks
1	Main Tunnel lining check	<p>Complete dewatering of the tunnel, then visual check of cast concrete:</p> <ul style="list-style-type: none"> • status of lining (aging, cracks, roughness, local defects check); • Joints check; • External waterstops (alignment, fixing elements, possible detachments, possible water percolations around the waterstops) • Eventual presence of water percolations; • record and check of settlements or displacement movements. • comparison of the values measured during previous inspections. At the first inspection the comparison shall be made with the records made at the date of completion of the tunnel construction. • Presence of materials and debris inside the tunnel shall be checked. Possible correlation with defects detected during the tunnel concrete lining inspection shall be carried out. 	<p>10 years, or in any case of abnormal water leaking record in the drain tunnels or surrounding rockmass. On the upstream portion only in case of need.</p>	<p>In case of observed damage to extended areas of lining a monitoring and mapping shall be performed by skilled people (see NOTES).</p> <p>In any case all anomalies, instable phenomena and presence of water percolation shall be recorded and appropriate actions taken (see NOTES)), to be defined on case by case basis.</p> <p>In case of presence of debris they shall be removed. The material found shall be analysed to identify its provenience (if it comes from rock , from river or from concrete lining elements). Than possible appropriate actions taken (see NOTES).</p>
2	Steel lining check (For any portion of the tunnel lined with steel)	<p>Whenever the waterway is emptied, check of the integrity and alignment of the welded junctions, and check of possible presence of cavitation zones, rust or paint damages on the steel lining. Check of integrity at intersection with concrete section. Check of circularity and good alignment of the steel lining sections. Such checks shall be done visually in any case, and with the aid of instruments as far as necessary to acquire all the information.</p>	<p>Whenever tunnel is emptied.</p>	<p>Eventual anomalies or damages in steel structure and junctions shall be documented and reported in all details, where possible quantifying the extension of the damage in a dedicated spreadsheet, in relevant drawings and by a set of photos. Than appropriate actions taken (see NOTES), to be defined on case by case basis.</p>
3	Access tunnels supports check	<p>Visual check of:</p> <ul style="list-style-type: none"> • status of lining (shotcrete and or bolts or ribs); • eventual presence of accumulated debris along the tunnel, as consequence of failure of potential instable wedges; • Eventual presence of water percolations 	<p>Every six months (at the end of dry and wet seasons) during impounding, than every 1 year.</p>	<p>In case of observed damage to extended areas of lining a monitoring and mapping shall be performed by skilled people (see NOTES). Than the area shall be scaled and cleaned and shotcrete or bolts applied again.</p> <p>In any case all anomalies, extended instable phenomena and presence of water percolation shall be recorded and appropriate actions taken (see NOTES).</p>
4	Access tunnels portals and relevant gates.	<p>Visual control and inspection of steel and concrete surface.</p> <p>Gates lock opening and closure test shall be done every year.</p>	<p>Every six months (at the end of dry and wet seasons) during impounding, than every 1 year. After 5 years, every 5 years.</p>	<p>In case of corrosion or damage to steel gate painting against corrosion shall be done, if possible, or alternatively the part shall be substituted.</p> <p>For actions on concrete structures, see NOTE 3.</p> <p>Ordinary maintenance of all concrete surfaces, metal works and finishing shall be done, as needed.</p>

NOTES:

- 1) In case of results or controls evidenced anomalies or problems, the measures shall be repeated for check, and then, if confirmed, the Plant Management direction shall be immediately informed and Direction involved in the dam safety consulted. According to the case the designer or a specialist consultant shall be consulted.
- 2) All operations shall be done by skilled personnel, instructed and authorised by the Plant owner for the operation required.
- 3) For check of concrete surfaces and of the status of the building and their finishing, the prescriptions provided in Pr.6 "Concrete surfaces" and Pr.7 "Control building, access buildings civil works and dam crest finishing" in table reported in chapter D.3.2 shall be applied.

Table 18 - Principal aspects and actions required for the Power Tunnel maintenance plan

Operation and maintenance of valves, gates, grids, relevant cranes and other HSS and EM equipment and instruments, located along the power waterways, are described in relevant section.

D.3.8 SURGE SHAFT MAINTENANCE

What follows is referred to one structure but applies for both left and right Surge shafts.

As far as the prescriptions for the civil works regarding the check of concrete surfaces, of the reinforced concrete structures and of the status of the building and their finishing, reference should be made to the prescriptions provided in Pr.6 "Concrete surfaces" and Pr.7 "Control building, access buildings civil works and dam crest finishing" in table reported in chapter D.3.2, which are not reported again in the following table.

Pr	Civil Feature	Description of check of performance indicators	frequency	Maintenance Actions - Remarks
1	Surge shafts yard slopes protection devices	<p>Visual check of the visible (not submerged) portions, in particular check of:</p> <ul style="list-style-type: none"> • status of shotcrete, bolts, drainages and drain ditches foreseen on benches • potential instable wedges. • Signal of movement or slides of slopes. • Debris accumulation on benches. • Check of possible crack openings or fissures or deterioration of concrete surfaces. <p>In case of continuous flow of water is observed coming out from drainage holes, the flow shall be monitored (quantifying the flow and reporting it on a spreadsheet).</p>	<p>After first Power waterways operation. Then yearly, preferably at the end of rainy season. Additionally in case of an exceptional heavy rain or earthquake event , or Power Waterways dewatering.</p>	<p>Any anomaly shall be duly recorded and signalled. Deeper checks (and check of possible dependence from meteo conditions) to be prescribed on case by case basis.</p> <p>If sliding phenomena or cracks opening are observed, they shall be monitored and, if necessary, slope stabilization measures reconsidered (see NOTES).</p> <p>In case of instable wedges to be scaled, the work shall be done by skilled people.</p> <p>Extended areas of damaged shotcrete shall be cleaned and repaired. Damaged bolts shall be replaced. Accumulation of debris on accessible benches or any obstruction of drain ditches or pipes shall be removed. Than a specialist designer shall be consulted.</p> <p>Ordinary maintenance and cleaning of the drain ditches shall be done, as needed.</p>
2	Steel parts	The external steel ladder and fences shall be periodically inspected by skilled personnel.	First visit 1 year after construction than	Eventual anomalies or damages in steel structure and junctions shall be documented and reported in all details, where possible quantifying the

		Special attention shall be paid in checking the bolted and welded junctions, and the integrity of the superstructures as well as presence of rust or paint damages.	frequency of controls to be defined, in any case no more than every 10 years	extension of the damage in a dedicated spreadsheet, in relevant drawings and by a set of photos, than appropriate actions taken (see NOTES). Ordinary maintenance of all steel parts shall be done, as needed.
NOTES:				
<p>1) In case of results or controls evidenced anomalies or problems, the measures shall be repeated for check, and then, if confirmed, the Plant Management direction shall be immediately informed and Direction involved in the dam safety consulted. According to the case the designer or a specialist consultant shall be consulted.</p> <p>2) All operations shall be done by skilled personnel, instructed and authorised by the Plant owner for the operation required.</p> <p>3) For check of concrete surfaces and of the status of the building and their finishing, the prescriptions provided in Pr.6 "Concrete surfaces" and Pr.7 "Control building, access buildings civil works and dam crest finishing" in table reported in chapter D.3.2 shall be applied.</p>				

Table 19 - Principal aspects and actions required for the Surge Shaft maintenance plan

The above applies for surge shafts concrete structures (yard, shafts below and above ground), other prescriptions for maintenance inspection and operation of such structures are provided in the table here below. For the maintenance of gates and all EM and HSS equipment, see relevant section.

Of course, for this structure, the portion that during normal operation of the plant is under water can be inspected only in the case of exceptional dewatering of the Power Waterways, that, unless for other exceptional needs, is recommended to be carried out every 10 years.

D.3.9 PENSTOCKS MAINTENANCE

What follows is referred to one structure but applies for both left and right Penstocks.

No specific maintenance is foreseen for Manifold and Penstocks steel lined conduits, being inside the rock and embedded in concrete.

Whenever for an exceptional event one or both the power waterways are emptied (see also prescriptions reported in the operation manual section), the general check of the integrity and alignment of the bolted and welded junctions, and the check of possible presence of cavitation zones, rust or paint damages can be conducted, as shown in the following table.

Pr	Civil Feature	Description of check of performance indicators	frequency	Maintenance Actions - Remarks
1	Steel parts	Whenever one or both the power waterways are emptied, check of the integrity and alignment of the bolted and welded junctions, and check of possible presence of cavitation zones, rust or paint damages on the steel lining.	Whenever tunnel is emptied.	Eventual anomalies or damages in steel structure and junctions shall be documented and reported in all details, where possible quantifying the extension of the damage in a dedicated spreadsheet, in relevant drawings and by a set of photos. Than appropriate actions taken (see NOTES).
<p>NOTES:</p> <p>1) In case of results or controls evidenced anomalies or problems, the measures shall be repeated for check, and then, if confirmed, the Plant Management direction shall be immediately informed and Direction involved in the dam safety consulted. According to the case the designer or a specialist consultant shall be consulted.</p> <p>2) All operations shall be done by skilled personnel, instructed and authorised by the Plant owner for the operation required.</p>				

Table 20 - Principal aspects and actions required for the Penstock maintenance plan

D.3.10 POWER HOUSE MAINTENANCE

What follows is referred to one structure but applies for both left and right Power Plants.

The general rules for the Power House civil works maintenance are resumed in the following table.

IMPORTANT REMARKS FOR STRUCTURE MONITORING:

- A) Usual ordinary maintenance and cleaning of civil works and architectural components is required for the functionality and durability of the Power House, as well as for all the other civil works structure, and it shall be therefore considered and planned as a part of the plant operation program.
- B) Another aspect important to be periodically monitored is the bathymetry of the Tailrace Hole. Whenever in this stretch of the river important sedimentation or rock elements accumulation would occur, this might have possible negative consequences for the energy production.
On the contrary, local deep erosion and scouring at the base of the Power House structure might compromise its stability.
In principle scouring is not expected here, and also sedimentation should not occur during the normal operation of the plant. Very exceptional floods discharged through the spillway might imply some transfer of material from plunge pool to tailrace hole.
- C) Any restrictions for the loads on civil structures, as well prescription for loading areas, indicated in the detailed design shall be considered when programming maintenance operations.

Pr	Civil Feature	Description of check of performance indicators	frequency	Maintenance Actions - Remarks
1	All reinforced concrete structures	Visual control and inspection of concrete surfaces of all structures (included upper and lower tank and diesel and GCB buildings)	Every year, or in case of exceptional flood, heavy rain or earthquake event	See NOTE 3). The first prescription about civil work regards the check of concrete surfaces, of the reinforced concrete structures and of the status of the building and their finishing, for which it shall be applied the prescriptions that are provided in Pr.6 "Concrete surfaces" and Pr.7 "Control building, access buildings civil works and dam crest finishing " in table reported in chapter 0 " DAM CIVIL WORKS ", to which reference shall be made (they are not reported again here).
2	Steel parts	All steel parts shall be periodically inspected by skilled personnel. Special attention shall be paid in checking the bolted and welded junctions, and the integrity of the superstructures as well as presence of rust or paint damages.	First visit 1 year after construction , than frequency of controls to be defined, in any case no more than every 10 years	Eventual anomalies or damages in steel structure and junctions shall be documented and reported in all details, where possible quantifying the extension of the damage in a dedicated spreadsheet, in relevant drawings and by a set of photos. Than appropriate actions taken (see Notes).
3	Control building and yard area finishing and architecture	Visual inspection of all the architectural and finishing elements inside and outside the Power House, such as: fence, illumination posts, illumination system and lamps, windows, doors, pavements, paintings, access roads, external yard finishing, pedestrian walks, gutters, ditches, cable trenches, handrails, steel ladders and platforms, ancillary works. The inspection shall be carried out by skilled people, able to identify possible defects that may require ordinary or extraordinary maintenance works.	Every year, or in case of exceptional flood, heavy rain or earthquake event	See NOTE 3). Possible wearing out, damages or defects on architectural elements shall be recorded and appropriate actions prospected to the Plant Owner for his action (see NOTES). Ordinary cleaning and maintenance of fence, roads, illumination system, frames, steel works, platforms, ancillary works and furniture shall be done, as needed. All sliding and rolling elements shall be maintained suitably lubricated (for instance the wheels of the cover structure on the erection bay roof opening).
4	Joints	Visual check of the good status of the joints and joints cover, inside and outside (on the roof) of the Power House.	Every year, or in case of exceptional flood, heavy rain or earthquake event	Eventual anomalies or damages of the joints shall be documented and reported in all details, where possible quantifying the extension of the damage in a dedicated spreadsheet, in relevant drawings and by a set of photos. Than appropriate actions taken (see Notes)
5	Water system and fire fighting system	Visual inspection of all the water system (tanks, pipes, pipelines, valves, roof gutters, taps and all fittings) inside and outside the Power House building. Water system is described in relevant report. Test of functioning of all pumps located in the lower tank chamber.	1 year Differently only in case specific defects or leaks on the hydraulic system are observed,	Eventual filtration, damages or cracks on tank structure shall be recorded and appropriate actions taken (see Note). Exposed reinforcement bars shall be treated as indicated at point 1. On off and functioning tests on all pumps, according to the relevant supplier operation and maintenance manual.

		<p>Test of fire fighting system as specified in EM operation and maintenance manual.</p> <p>Check of potabilizer.</p>	<p>or in case of fire event.</p>	<p>Every year lamps of UV potabilizer device and filters must be changed.</p> <p>Ordinary maintenance and cleaning of pipes, pipelines, valves, roof gutters, taps and all fittings to be done periodically, as needed.</p>
6	External drainage system	<p>All around the Power House area (on yards, road and slopes) visual check of:</p> <ul style="list-style-type: none"> - Drainage pits - Ditches - Pipes <p>Ordinary maintenance and cleaning of ditches and gutters shall be carried out, especially during the rainy seasons.</p>	<p>1 year</p> <p>Always after very heavy rainfall event occurred.</p>	<p>In case of big damages to any drainage structure is observed, it shall be documented and reported in all details, where possible quantifying the extension of the damage in a spreadsheet, in relevant drawings and by a set of photos.</p> <p>Than appropriate actions taken (see Note); for damages to reinforced concrete see relevant point 1.</p> <p>Eventual obstructions (mud, debris, grass) of ditches, pits, pipes and discharging structures shall be removed by a periodic cleaning.</p>
7	Transformers oil/water system	<p>See detailed description at next paragraph TRANSFORMER OIL WATER RECOLLECTION SYSTEM DESCRIPTION</p>	<p>5 years</p> <p>Always after every firefighting event.</p>	<p>See detailed description provided in next paragraph TRANSFORMER OIL WATER RECOLLECTION SYSTEM DESCRIPTION</p>
8	Sewage system	<p>Sewage treatment and septic tank.</p> <p>In the bottom of the septic tank, the solid particles will sedimentate.</p> <p>When the level of the solids reaches half height of the tank, typically the solids must be pumped out.</p> <p>Following the first emptying, it is possible to define better the required emptying time, according to the supplier operation manual.</p> <p>Periodical visual inspection of the tank level is therefore required.</p>	<p>In the first year:</p> <p>every three months.</p> <p>After the first year, to be defined according to the results of the first inspections</p>	<p>Pumping out of the solids by means of portable pump.</p>
9	Power House slopes protection devices	<p>Visual check of:</p> <p>status of barriers and rock-fall nets and protection barriers (if present) foreseen on benches above the yard;</p> <p>accumulation of debris behind protection net;</p> <p>potential instable wedges.</p> <p>Possible crack opening on the shotcrete or rock of the exposed front of excavation.</p> <p>Shotcrete and bolts where foreseen.</p> <p>Drainage water percolation.</p>	<p>1 year</p> <p>Always after very heavy rainfall event occurred.</p>	<p>Possible problems observed shall be measured, documented and reported in all details, where possible quantifying the extension of the damage in a dedicated spreadsheet, in relevant drawings and by photos.</p> <p>Than appropriate actions taken (see NOTES).</p> <p>In case of corrosion or damage to steel parts (ropes, pillars, junctions, meshes,..) painting against corrosion shall be done, if possible, or alternatively the part shall be substituted.</p> <p>In any case all anomalies shall be recorded and appropriate actions taken (see Note).</p> <p>Excessive accumulation of debris behind protection net (if present) shall be removed by skilled people.</p> <p>Scaling of instable wedges shall be done by skilled people.</p> <p>Extended areas of damaged shotcrete shall be cleaned and repaired.</p> <p>Damaged bolts shall be replaced.</p>

				<p>In case of continuous flow of water is observed coming out from drainage holes, the flow shall be monitored (quantifying the flow and reporting it on a spreadsheet). Than a specialist designer shall be consulted.</p> <p>Ordinary maintenance of all steel and concrete parts shall be done, as needed.</p>
10	Submergible parts of the structure	In case of flood event all submerged structures shall be than inspected and visual check of all part shall be made.	Always after flood event	<p>Ordinary cleaning and drying of all floors below level of the river, inside Power House, taking water for cleaning from nearest available water taps.</p>
11	400kV line anchorage	Visual check of status of 400kV line anchors and anchorage devices behind Power House	2 years	<p>In case of corrosion or damage to steel parts (ropes, rings, junctions) painting against corrosion shall be done, if possible, or alternatively the part shall be substituted.</p> <p>In any case all anomalies or movements shall be recorded and appropriate actions taken (see Note).</p> <p>Ordinary maintenance of all steel parts shall be done, as needed.</p>
12	Yard and access roads	<p>Visual check of status of the access road and relevant cut or embankments.</p> <p>Visual check of status of the yard and relevant works (gates, nets, protection walls, barriers, architectural elements)</p>	<p>Every year, preferably after rainy season</p> <p>Always after very heavy rainfall or flood or earthquake event occurred.</p>	<p>In case of major instability phenomena are observed, they shall be monitored, documented and reported in all details, where possible quantifying the extension of the damage in a dedicated spreadsheet, in relevant drawings and by a set of photos.</p> <p>Than appropriate actions taken (see Note).</p> <p>Along the road eventual obstructions of ditches, pits, pipes shall be removed by a periodic cleaning.</p> <p>On roads and yards ordinary maintenance of all steel and concrete parts (gates, nets, protection walls, barriers) shall be done, as needed, and repaired if and when necessary.</p>
13	Tailrace Hole	<p>It is requested, in dry season, the visual check of status of the tailrace hole (for the portion outside the water) and relevant sustaining structures (walls, supports, etc.).</p> <p>It is recommended a check of the bathymetry along the tailrace hole in front of the draft tube. This check is to be done preferably in dry season and preferably in the moment of turbines stop.</p>	<p>First time 1 wet season after Plant commissioning, than every 2 years. After 5 years, every five years.</p> <p>Always after very heavy rainfall or flood event occurred.</p>	<p>In case of major instability phenomena are observed, they shall be monitored, documented and reported in all details, where possible quantifying the extension of the damage in a dedicated spreadsheet, in relevant drawings and by a set of photos.</p> <p>Than appropriate actions taken (see Note).</p> <p>Damages to the protections shall be repaired as soon as possible.</p> <p>The bathymetry shall be compared with the tailrace hole geometry indicated in design drawings and in as built drawings.</p> <p>In case of significant (more than 1m in elevation) end extended differences in respect to the design profile, or in case of obstruction of the draft tube outlet, the actual profile shall be duly recorded and reported, quantifying the extension of the damage in</p>

					relevant drawings and by a set of photos if possible. Than appropriate actions taken (see Notes).
NOTES:					
<p>1) In case of results or controls evidenced anomalies or problems, the measures shall be repeated for check, and then, if confirmed, the Plant Management direction shall be immediately informed and Direction involved in the dam safety consulted. According to the case the designer or a specialist consultant shall be consulted.</p> <p>2) All operations shall be done by skilled personnel, instructed and authorised by the Plant owner for the operation required.</p> <p>3) For check of concrete surfaces and of the status of the building and their finishing, the prescriptions provided in Pr.6 "Concrete surfaces" and Pr.7 "Control building, access buildings civil works and dam crest finishing" in table reported in chapter D.3.2 shall be applied.</p>					

Table 21 - Principal aspects and actions required for the Power House maintenance plan

D.3.11 SWITCHYARD MAINTENANCE

What follows is referred to one yard but applies for both left and right Power Plants.

The general rules for maintenance needed for the CIVIL WORKS at Switchyard are resumed in the following table.

As far as the prescriptions for the civil works regarding the check of concrete surfaces, of the reinforced concrete structures and of the status of the building and their finishing, reference should be made to the prescriptions provided in Pr.6 "Concrete surfaces" and Pr.7 "Control building, access buildings civil works and dam crest finishing " in table reported in chapter D.3.2, which are not reported again in the following table.

Operation and maintenance of electromechanical equipment and of all towers are described in relevant EM equipment operation manuals.

Pr	Civil Feature	Description of check of performance indicators	frequency	Maintenance Actions - Remarks
1	Concrete structures	Visual control and inspection of exposed concrete surfaces, relevant to: <ul style="list-style-type: none"> • EM equipment foundation blocks, • Cable trenches • control building • Water tank • Drain system structures (pits, ditches, dissipating structures) 	Every year	See NOTE 3). The first prescription about civil work regards the check of concrete surfaces, of the reinforced concrete structures and of the status of the building and their finishing, for which it shall be applied the prescriptions that are provided in Pr.6 "Concrete surfaces" and Pr.7 "Control building, access buildings civil works and dam crest finishing " in table reported in chapter 0 "DAM CIVIL WORKS", to which reference shall be made (they are not reported again here).

2	Control building and switchyard area finishing and architecture	<p>Visual inspection of all the architectural and finishing elements of the building and of the yard, such as: Fence, illumination posts, illumination system and lamps, windows, doors, pavements, paintings, access roads, external yard finishing, pedestrian walks, gutters, guardian box, fountain.</p> <p>The inspection shall be carried out by skilled people, able to identify possible defects that may require ordinary or extraordinary maintenance works.</p>	<p>First time, 1 year after impounding, then every 5 years</p>	<p>See NOTE 3). Possible wearing out, damages or defects on architectural elements shall be recorded and appropriate actions prospected to the Plant Owner for his action (see Note).</p> <p>Ordinary maintenance of fence, roads, illumination system and ancillary works shall be done, as needed.</p>
3	Sewage system	<p>Sewage treatment is made in the septic tank, located near the control building.</p> <p>In the bottom of the septic tank, the solid particles will sedimentate. When the level of the solids reaches half height of the tank, the solids must be pumped out.</p> <p>Following the first emptying, it is possible to define better the required emptying time, according to the supplier operation manual.</p> <p>Periodical visual inspection of the tank level is therefore required.</p>	<p>In the first year: every three months.</p> <p>After the first year, to be defined according to the results of the first inspections.</p>	<p>Pumping out of the solids by means of portable pump.</p>
4	Control building water system	<p>Visual inspection of all the water system (tanks, pipes, pipelines, valves, roof gutters, taps and all fittings) inside and outside the Switchyard building. Water system is described in relevant report.</p> <p>Test of functioning of all pumps located in the lower tank chamber.</p> <p>Check of potabilizer.</p> <p>Check of the air chamber of the pump inside the tank, according to the operation manual of the pump supplier.</p> <p>All these checks shall be of visual type, made by a qualified plumber.</p>	<p>1 year, preferably after the rainy season</p> <p>Differently only in case specific defects or leaks on the hydraulic system are observed.</p>	<p>Possible filtration, damages or cracks on tank structure shall be recorded and appropriate actions taken (see Note and see operation 1 above). Exposed reinforcement bars shall be treated as indicated at point 1.</p> <p>On off and functioning tests on all pumps, according to the relevant supplier operation and maintenance manual.</p> <p>Every year lamps of UV potabilizer device (if present) and filters must be changed.</p> <p>Ordinary maintenance and cleaning of pipes, pipelines, valves, roof gutters, taps and all fittings to be done periodically, as needed.</p>

NOTES:

- 1) In case of results or controls evidenced anomalies or problems, the measures shall be repeated for check, and then, if confirmed, the Plant Management direction shall be immediately informed and Direction involved in the dam safety consulted. According to the case the designer or a specialist consultant shall be consulted.
- 2) All operations shall be done by skilled personnel, instructed and authorised by the Plant owner for the operation required.
- 3) For check of concrete surfaces and of the status of the building and their finishing, the prescriptions provided in Pr.6 "Concrete surfaces" and Pr.7 "Control building, access buildings civil works and dam crest finishing" in table reported in chapter D.3.2 shall be applied.

Table 22 - Principal aspects and actions required for the Switchyard maintenance plan

D.3.12 ACCESS ROADS MAINTENANCE

Here below are resumed the main guidelines and actions required for the maintenance plan relevant to the ACCESS ROADS pertaining to the site of Batoka.

For the main (asphalted or paved) roads reaching the site, the maintenance and operation activities shall be undertaken by the national roads authorities (by Zambia and Zimbabwe, as far as their territory of competence) in the frame of their regulations and procedures.

Pr	Civil Feature	Description of check of performance indicators	frequency	Maintenance Actions - Remarks
1	Site access roads stability	<p>Visual check of:</p> <ul style="list-style-type: none"> status of shotcrete, bolts, drainages and drain ditches foreseen on benches potential instable wedges. Signal of movement or slides of slopes. Debris accumulation on benches or drain ditches. Check of possible crack openings or fissures or deterioration of concrete surfaces. <p>In case of continuous flow of water is observed coming out from drainage holes, the flow shall be monitored (quantifying the flow and reporting it on a spreadsheet).</p>	Yearly, preferably at the end of rainy season. Additionally in case of an exceptional heavy rain or earthquake event.	<p>Any anomaly shall be duly recorded and signalled. Deeper checks (and check of possible dependence from meteo conditions) to be prescribed on case by case basis.</p> <p>If sliding phenomena or cracks opening are observed, they shall be monitored and, if necessary, slope stabilization measures reconsidered (see NOTES).</p> <p>In case of instable wedges to be scaled, the scaling shall be done by skilled people.</p> <p>Extended areas of damaged shotcrete shall be cleaned and repaired.</p> <p>Damaged bolts shall be replaced.</p> <p>Accumulation of debris on roads or accessible benches or any obstruction of drain ditches or pipes shall be removed. Than a specialist designer shall be consulted.</p> <p>Ordinary maintenance and cleaning of the drain ditches, as needed.</p>
3	Kerb, parapets, masonry protection walls, retaining walls, concrete paving or ramps	<p>Visual check of good status of the concrete surface, including check of:</p> <ul style="list-style-type: none"> Presence of fissures or cracks; Detachment of finishing concrete layers Damages (erosion, holes, cracks) on concrete surfaces 	In case of Power Waterways dewatering.	<p>See NOTE 3).</p> <p>Any anomaly shall be duly recorded and signalled, possibly associated with measures of meteo conditions (see NOTES).</p> <p>Repairing intervention, if needed shall be properly designed and conducted by skilled people, in safe conditions.</p>

NOTES:

- 1) In case of results or controls evidenced anomalies or problems, the measures shall be repeated for check, and then, if confirmed, the Plant Management direction shall be immediately informed and Direction involved in the dam safety consulted. According to the case the designer or a specialist consultant shall be consulted.
- 2) All operations shall be done by skilled personnel, instructed and authorised by the Plant owner for the operation required.
- 3) For check of concrete surfaces and of the status of the building and their finishing, the prescriptions provided in Pr.6 "Concrete surfaces" and Pr.7 "Control building, access buildings civil works and dam crest finishing" in table reported in chapter D.3.2 shall be applied.

Table 23 - Principal aspects and actions required for the Access Roads maintenance plan

The ordinary frequent maintenance operation is essential to maintain functional the access to the site.

This continuous maintenance operation shall be not neglected or considered as secondary, to maintain efficient the roads, and resources and planning for such activity shall be organized by the PMS.

D.3.13 PERMANENT CAMP

What follows is referred to one camp but applies for both left and right Power Plants.

For the PERMANENT CAMPS maintenance, the following general instructions apply.

As far as the prescriptions for the civil works regarding the check of concrete surfaces, of the reinforced concrete structures and of the status of the building and their finishing, reference should be made to the prescriptions provided in Pr.6 "Concrete surfaces" and Pr.7 "Control building, access buildings civil works and dam crest finishing " in table reported in chapter D.3.2, which are not reported here again.

General prescriptions for roads maintenance described in previous chapter D.3.12 "ACCESS ROADS" are valid.

General prescriptions for maintenance of excavation fronts and local supports of excavation and backfilled areas as described at point 9 of table reported in chapter D.3.10 are valid.

The size of the camp, its facilities and schemes of its services (water and power supply) are described in relevant drawings of Feasibility Design, and are assumed will be detailed in further steps of the design.

For the detailed instructions of operation and maintenance of the houses, the services systems (water, sewage, electric, ventilations or air conditioning, fire-fighting systems) pertaining to the houses and to the common spaces (canteen, pool, guardian room, etc.) dedicated specific manuals or instructions will be provided out of this report for the perusal of the staff charged to conduct and maintain the camp, when the detailed design will be produced.

It remains a key and essential factor for the proper use and long life of the permanent camp, the ordinary frequent maintenance operation of indoor and outdoor spaces (included the green areas).

This continuous maintenance and ordinary curing operation shall be not neglected or considered as secondary, to maintain efficient the camp, and resources and planning for such activity shall be organized by the PMS.

D.3.14 HYDRAULIC DEVICES AND MAIN CONTROL EQUIPMENT MAINTENANCE

GENERAL

The operations and maintenance manuals relevant to the Electro mechanical (EM) and Hydraulic steel structure (HSS) equipment will be provided by the EM and HSS equipment suppliers.

Mechanical and electrical equipment require appropriate maintenance and testing. Gates, lifting equipment and power supplies should be continuously maintained during frequent inspections and minor maintenance works.

The ultimate aim of the maintenance activities is to ensure that the plant is capable of reliably performing its operational functions with no forced outages and at the minimum maintenance cost. The equipment must always be in good working order and be capable of both normal and emergency operation.

In this chapter guidelines for mechanical and electrical equipment main testing and maintenance operation are provided because they are of utmost importance being most of these equipments essential for the safe operation of the plant.

The maintenance of all such equipment shall be carried out in any case according to the detailed instruction provided in their relevant manuals that will prevail in case of conflict with the general instructions here reported.

What follows can be adjusted or modified or updated as needed with the development of the detailed design and of the construction.

TIME BASED TESTING, INSPECTION AND MAINTENANCE

Here below there is provided a table indicating the type and frequency of tests that are envisaged to be conducted for all the important equipment of the plant, in order to be sure that they function properly when their use is needed.

It is essential to document thoroughly the measured results and to identify any declining trend of any component of the plant.

The guidelines provided in the table are grouped where possible for the following Type of Equipment:

A) EMERGENCY POWER SUPPLY SYSTEM

- ✓ Diesel generators for Emergency Power Supply

B) HYDRAULIC GATES

- ✓ Spillway radial gates (with oleo-dynamic unit)
- ✓ Middle Outlet downstream gates (with oleo-dynamic unit)
- ✓ Power House draft tube gates (with oleo-dynamic unit)
- ✓ Middle Outlet upstream gates

- ✓ Power Tunnel upstream gates

C) STOPLOGS

- ✓ Spillway stoplogs
- ✓ Power House draft tube stoplogs

D) VALVES

- ✓ Power House Main Inlet Valves
- ✓ Power House ecological discharge pipe guard valves
- ✓ Power House ecological discharge valve
- ✓ Power House hydraulic system pipes and tanks valves
- ✓ Transformers oil-water discharge system pipes and tanks valves

E) CRANES

- ✓ Dam crest crane (for Spillway and Middle Outlet upstream gate)
- ✓ Power Waterways Intake Gates monorail crane
- ✓ Power House main crane
- ✓ Power House auxiliary crane
- ✓ Power House Erection Bay gantry crane
- ✓ Power House stoplogs gantry crane
- ✓ Power House internal monorail crane (for draft tube gates lifting)

F) HOISTS

- ✓ Power House drain system pumps hoists
- ✓ Power House diesel generator building hoist (for transformers)
- ✓ Power Waterways Intake Gates hoists
- ✓ Power Waterways Intake Gates control room hoist (for pumps)
- ✓ Dam Pumping system pits hoists
- ✓ Dam diesel generator building hoist (for transformers)
- ✓ Switchyard control building hoist (for transformers)
- ✓ Penstocks man-hole chambers hoist

G) LIFTS

- ✓ Power House lifts
- ✓ Dam cable duct lift

H) PUMPS

- ✓ Dam drainage pumping system
- ✓ Power House drainage pumping system
- ✓ Power House fire fighting and service water system pumps

HYDRAULIC DEVICES AND MAIN CONTROL EQUIPMENT MAINTENANCE				
Maintenance Category	Type of Equipment	Check Activity	Frequency (*)	Description of the tasks
Testing (*)	EMERGENCY POWER SUPPLY SYSTEM	Start, Load, Stop	Monthly	Verify start reliability of diesel generator on loss of normal power supply and lubrication oil pressure, generating set vibration, fire valve status. Ensure batteries are fully charged. After use check and refill if necessary gasoil in the tanks.
	HYDRAULIC GATES (with their Hoisting devices)	Opening/ Closing fully Partial in case of drought	Yearly	Test operate gates and record motor currents, gate positions and time during gate operation. Use normal and emergency power supply. Record power absorbed by relevant motor and lifting/closing times. Check gate and valve operation throughout the full gate and valve opening and closing stroke. If necessary gate position re-calibration and testing. Check for foreign noises and smells from motors and control equipment.
Testing (continue)	HYDRAULIC GATES (with their Hoisting devices)	Non-destructive testing of gate hoists	5 yearly	Testing of ropes, equipment attachment points
	STOPLOGS	Opening/ Closing fully	2 yearly	Test operate stoplogs, gate positions and time for their installation. Use normal and emergency power supply for their lifting. Record power absorbed by electric motor and lifting/closing times.
	VALVES	Opening/ Closing fully Partial in case of drought	Yearly	Use normal and emergency power supply. Record pressure of hydraulic servomotors, or power absorbed by electric motors and opening/closing times. Check setting of hydraulic set relief valve. Check possible leakage of water through the closed valve.

	CRANES and LIFTS	Non-destructive testing	5 yearly	<p>Testing of ropes, equipment attachment points.</p> <p>Test the movement of the main crane and its hoist for all possible configuration and extension, with and without applied loads.</p> <p>Test operate crane or lifts and record motor currents, positions and time during operation. Use normal and emergency power supply. Record power absorbed by relevant motor and lifting/closing times. If necessary crane rail alignment re-calibration and testing. Check for foreign noises and smells from motors and control equipment.</p>
	HOISTS	Non-destructive testing	5 yearly	<p>Testing of ropes, equipment attachment points. Test the movement of the monorail crane and its hoist for all possible configuration and extension, with and without applied maximum nominal load.</p>
	PUMPS	Start, Load, Stop	2 monthly	<p>Verify start reliability and functionality for the set levels of functioning, check proper functioning in relation of relevant control and floating system in the pits.</p>
	General (as far as applicable to all type of equipment)	Opening/ Closing fully	Yearly	<p>Inspect controls indications, sirens and warning lights as applicable.</p> <p>Water level sensor re-calibration and testing.</p>
Inspection	General (as far as applicable to all type of equipment)	Visual inspections and Checks	Monthly	<p>Check for any anomalies, hazards or security risks.</p> <p>Check all lubrication and top-up lubricants as required.</p> <p>Check gates and valves hydraulic system oil levels.</p>
	EMERGENCY POWER SUPPLY	Close examination of diesel generator set conditions, replace air and oil filters	Six monthly	<p>Verify coolant, motor heating, fuel supply, battery charge. Check tension of driving belts. Check electrical auxiliaries. Check all alarms and shutdown switches.</p>
	HYDRAULIC GATES (with their Hoisting devices)	Visual examination of gates, seals, guide pads, steel ropes, screws, winch, brakes, contactors.	Six monthly	<p>Check any wear and tear; measure vibration, motor electric insulation resistance. Examine ropes for broken strands, crushing, kinking. Examine gear train. Inspect paint and check any corrosion. Check gearbox oil level. Check brakes lining. Check gate lifting limit switches.</p>

	VALVES and their Actuators	Visual examination of valve seal, sliding guides, leakage.	Six monthly	Check wear and tear, paint, and water leakage. Check hydraulic set leakages and re-pumping time. Verify accuracy of their position indication instruments.
	CRANES	Visual examination of wheels, guide pads, steel ropes, screws, winch, brakes, contactors.	Six monthly	Verify mechanisms, check tension of driving belts. Check electrical auxiliaries. Check brakes and control devices. Check all alarms and shutdown switches.
	STOPLOGS	Visual examination of seals and sliding guides	5 yearly	Check wear and tear and paint. Check status of sealing elements.
	PUMPS	Visual examination of pumps and relevant guides and pipes	5 yearly	Check wear and tear and paint. Check status of sealing elements, check status of anchorage and bolts.
Maintenance	EMERGENCY POWER SUPPLY SYSTEM (**), GATES, VALVES, CRANES, HOISTS, LIFTS, PUMPS	General maintenance	Monthly/ Annually	As per supplier's O&M recommendations (Grease bearings, check for hydraulic system oil leaks, motor contactors, brake solenoid, brake pads, gate seals, gate guide pads and all other recommended tasks). Re-order any spares. (**)
	CRANES, HOISTS and LIFTS	Check lubrication of moving parts of hoists and winch units	Monthly	Grease moving parts as required. Other actions as per supplier's O&M recommendations
	General (as far as applicable)	General safety checks	5 yearly	Check condition of all handrails, ladders and other equipment critical for personnel safety
	General	Updating of documentation	Annually	Ensure operating procedures, emergency planning and contact documentation and other relevant reference documentation is up to date.

Table 24 - Hydraulic devices and main control equipment maintenance

(*) At Batoka it is likely that some valves or gates or cranes will be frequently operated under flow, in which case the corresponding formal tests may not be required. However, it needs to be ensured that the observation and data recording requirements described in the table above are met, and that at least some of these valve operations are carried out via the emergency diesel power supply.

(**) Maintenance tasks and frequency for the emergency diesel generator should be based on the diesel generator supplier's O&M manuals. As a minimum the following checks and appropriate follow-up actions would be expected:

-
- Walk around visual inspection;
 - Check engine oil and coolant levels;
 - Check fuel level;
 - Check fan belt tensions;
 - Check hoses for loose connections or deterioration;
 - Check battery connections for corrosion and check battery electrolyte;
 - Check dust and oil build-up, oil leaks and fuel leaks;
 - Check and empty bunding;
 - Check all system protection by simulating a fault;
 - Check all battery caps as applicable;
 - Tighten all electrical connections and exhaust connections;
 - Change oil and filters;
 - Start the diesel motor and check gauges and meters are working correctly;
 - Run on load bank for 30 minutes.

GENERAL GUIDELINES FOR EQUIPMENT CONDITION MONITORING

Condition assessment of equipment and condition-based maintenance are the two fundamental aspects of predictive maintenance which is aimed at carrying out maintenance activities only when the decline of equipment performance reaches a predefined level, thereby minimizing both the predictive maintenance and the occurrence of equipment malfunction.

Condition monitoring and condition-based maintenance guidelines are described below.

- **TESTING OF ELECTRIC MOTORS AND DATA LOGGING**

The following data should be recorded during all testing of electric motors:

- Date and time;
- Name of operator carrying out the test;
- Gate position;
- Motor current and voltage.

All test data should be analysed by suitably qualified personnel and compared against previous results to check for any changes in performance. The results shall be reported appropriately and any necessary corrective maintenance actions shall be undertaken.

- **INSPECTION AND DATA-LOGGING OF GATE, VALVE AND LIFTING EQUIPMENT OPERATION**

It is essential that from time to time gate, penstock inlet valve and lifting equipment operation is recorded and observed by suitably qualified and experienced personnel. In addition to an assessment of gate and valve opening and closing times, the observations should include gate sealing and seating characteristics, gate vibration, noise or any other signs of distress.

- **INSPECTION OF COATING SYSTEMS**

The life of hydraulic gates, bulkheads and associated lifting equipment can be extended significantly if their coating systems are monitored and maintained in good condition. Generally coating systems for such applications have a life expectancy of 20 to 40 years, depending on coating technique and quality of the paint system. In addition, life expectancy largely depends on environmental factors and the life may be significantly reduced in presence of sand erosion that cannot be excluded at Batoka Dam site. Frequent repairs to the coating systems are likely to be required to prevent corrosion from affecting the structural integrity of the gates.

- **MAJOR REFURBISHMENT OR REPLACEMENT**

End-of-life is considered to be the point at which either major component replacement or refurbishment is required. Typically gate refurbishment will involve gate removal, sand-blasting and re-painting, seal replacement, repair or replacement of gate rollers and/or gate roller bushes and repair work to the embedded steel work in the gate slot. Repair or replacement of components of the lifting system will be carried out as required at the same time.

D.4 TYPICAL FORMAT FOR INSPECTION CHECK SHEET

Hereinafter is provided the typical format for inspection check sheet.

BATOKA PLANT - ISPECTION CHECKLIST

Inspection	Comment
Inspector (name)	
Date and Timing	Date: Inspection start time: Inspection finish time:
Reservoir (or river ⁽¹⁾) Level	_____ m a.s.l.
Flow discharged ⁽¹⁾	_____ m ³ /s
Conditions	Sunny / Overcast / Raining / Windy / Storm / Flood / Earthquake
Rainfall over past week	High / medium / low _____ mm (if available)

(1) = only if applicable, depending on where the inspection is conducted.

Checklist n. / (a)	WORK: (b)	Observed		Significance ^(f)		
Operation /Civil Feature	Aspect inspected / Performance Indicator	Yes	No	Minor	Moderate	High
		(c)	(d)	(e)		(f)
Comments	(e)					
(c)	(d)	(e)		(f)		
Comments	(e)					

- (a) = insert the progressive number and date
- (b) = insert the part of the work checked (for instance "BRIDGE")
- (c) = insert the civil feature/operation, taking the description from the table reported in this report at the chapter corresponding to the work under check (for instance "Bearings periodic check", or adding other description as far as needed or appropriate.
- (d) = insert the description of the performance indicator or the aspect inspected (one per line), taking the description from the corresponding column in the table reported in this report at the chapter corresponding to the work under check (for instance "Absence of movement or anomalous deformations"), or adding other description as far as needed or appropriate.
- (e) = insert the observation of presence or not of the performance indicator (Place a ✓ in the appropriate box), and/or if necessary qualifying the observation in the box of the comments. Add if necessary comments on any abnormal or changed conditions.
- (f) = qualify the performance indicator as follows:
 - Minor** = The performance indicator observed but does not require maintenance.
 - Moderate** = The performance indicator observed and requires action to remediate.
 - High** = Prompt action should be taken to address the issue

Signature: _____

Date: _____

(Inspector)

Other lines can be added to this format as far as needed.

PART E - EMERGENCY PREPAREDNESS PLAN
(Framework Plan)

E.1 INTRODUCTION

E.1.1 CONTENT AND STRUCTURE OF THIS PART

This is the **PART E "EMERGENCY PREPAREDNESS PLAN (Framework Plan)"** of the Batoka Dam Safety Plan. This part contains the Batoka Emergency Preparedness Plan (Framework Plan) that includes:

- description of types of emergencies and how to identify them,
- actions to take in an emergency.
- preparedness and Emergency Response
- Dam Break analysis

Based on this framework, the Emergency Preparedness Plan will be prepared during implementation of the project, in compliance with WB guidelines (OP 4.37), not later than one year before the initial filling of the reservoir.

This part of the report is divided in the following chapters:

1) FOREWORD

Describes the content of the report and its structure.

2) STRUCTURE AND REVIEW OF THE PLAN

It outlines the structure and the purpose of the plan, the needs for its review and for its implementation in details, and the principles on which is based.

3) EMERGENCY CASES

This chapter provides a synthetic description of the type of emergencies.

4) INITIATION OF THE EMERGENCY ACTION PLAN

This chapter describes how to identify and evaluate an emergency case.

5) EMERGENCY RESPONSE AND ACTION PLANS

This chapter provides a description of the initial response and emergency inspections to be carried out in case of need, and the typical emergency action plans identified for this project.

6) EMERGENCY PREPAREDNESS PLAN

This chapter provides the plan and procedure for emergency preparedness.

7) CONTINGENCY PLAN

This chapter illustrates how to manage exceptional cases having impact on the safety of the people and of the structures, and relevant alarms triggering.

8) DAM BREAK ANALYSIS

This chapter illustrates the results of the hydraulic calculation to identify the flooded areas in case of dam break. The evaluated scenario foresees the incoming of an extreme climate event meteorological event, which causes dam overtopping and presents the study of the flood propagation for a river stretch of approximately 120 km length, along the Zambezi river, from the Batoka dam up to the Lake Kariba.

E.2 STRUCTURE AND REVIEW OF THE PLAN

E.2.1 GENERAL

This Emergency Preparedness Plan (Framework Plan) for Batoka Plant has the purpose to limit possible damage to the dam and appurtenant structures and also areas downstream and prevent loss of life by guiding personnel on what to do, when and how.

This document sets out the guidelines to:

- define, identify and evaluate events with the potential to compromise the dam and appurtenant structure safety.
- Establish procedures for declaring an event as a dam safety emergency.
- Detail actions to be taken in response to the dam safety emergency (through Emergency Action Plans (EAP)).
- Establish communications to minimise the consequences of the dam safety emergency.

It shall be integrated and detailed by the PMS that will be in charge to organize and implement it.

This document presents procedures for Emergency Action Plans (EAP) for the dam site.

Response plans for areas outside Batoka site will be developed separately by the Local Authorities.

This plan must be completed to reflect final design, actual conditions on site, and afterwards shall be reviewed and updated:

- on completion of the Plant Construction
- During operation:
 - When any significant change to the scheme occurs, including any changes to the operating rules of the Plant.
 - At intervals of 5 years.
 - Following any ownership change.

E.2.2 PRINCIPLES

The following principles underlie the emergency actions for all dam safety emergencies:

- **PERSONNEL SAFETY** must be considered **FIRST** at all times;
- The primary defence if a dam failure scenario is developing or if the dam is seriously damaged, is to **LOWER THE RESERVOIR LEVEL**. This is achieved by opening outflow controls;
- If a serious leak occurs in the Power Waterways or Power House, or they are seriously damaged, then **CLOSE THE POWER WATERWAYS GATES** to stop the water source.

This EPP assumes that the Plant is manned full time, 24 hours a day, 7 day a week, and that the dam site is occupied and managed by a full time PMS Operator working and connected with the Owner(s) of the Plant.

It is assumed that for the life of the dam the PMS/Owner(s) is responsible for ensuring that appropriate measures are taken and sufficient resources provided for the safety of the dam.

E.3 EMERGENCY CASES

E.3.1 TYPE OF EMERGENCIES and RESPONSE LEVEL MATRIX

A Dam Safety Emergency is an event that has the potential of endangering the integrity of the dam or appurtenant structures, and therefore requires immediate action.

The hazard events identified at Batoka Plant and the associated response levels are described in the following table that shall be used to initiate emergency action plan.

Some further clarifications and descriptions are given in next paragraphs, in sake of completeness.

RESPONSE LEVEL		TYPE OF EVENT								
	1a	1b	2	3	4	5	6	7	8	
Internal Alert Situation can be managed internally. Outside notification NOT required	Excessive leaks through dam. Movement of a portion of dam body along horizontal RCC surface detected through monitoring of pendula, deformometers or joint meters. Dam drains and/or piezometers monitoring displacements passes from "routine" to "alert" criteria.	Excessive leaks recorded through dam drains intercepting foundations. Movement or displacements of a portion of dam body detected through monitoring of pendula, deformometers or joint meters. Ground aquifer level and/or flow trend start to raise independently from reservoir fluctuations. Dam foundation drains and/or piezometers monitoring passes from "routine" to "alert" criteria.	Excessive leaks through power waterways drainage system. Dam drains and/or piezometers or displacements monitoring passes from "routine" to "alert" criteria.	Earthquake less than OBE recorded through dedicated instruments.	Excessive leaks detected through available drains (HILO drains, Spillway external drains, Power Waterways drain system, Power Houses drain pumping system). Local drains monitoring system passing from "routine" to "alert" conditions.	Failure of spillway gates or HILO gates, or Power Waterways gates or Power House gates, or relevant power/control systems.	Anomalous scouring recorded through specific bathymetric check after exceptional flood event or after exceptionally prolonged use of spillway/middle level outlets. Movement or displacements of a portion of dam body detected through monitoring of pendula, deformometers or joint meters. Dam foundation drains and/or piezometers monitoring passes from "routine" to "alert" criteria.	Heavy rain forecast. Reservoir level records above Maximum Operating Level. Reservoir levels monitoring passes from "routine" to "alert" criteria.	Extreme weather warning	Sabotage/accident
	Increasing rate of excessive leaks through foundation drains. Heavy seepage carrying fines detected through piezometers and dam foundation drains. Ground aquifer level and/or flow trend raising independently from reservoir fluctuations. Visible movements or cracks in the dam body. Anomalous displacements recorded through invert pendula or dam deformometers.	Increasing rate of excessive leaks through foundation drains. Heavy seepage carrying fines detected through piezometers and dam foundation drains. Ground aquifer level and/or flow trend raising independently from reservoir fluctuations. Visible movements or cracks in the dam body. Anomalous displacements recorded through invert pendula or dam deformometers.	Increasing rate of excessive leaks through left abutment drain system. Seepage carrying fines detected through left abutment piezometers and drains. Groundwater level and/or drain flow trend raising independently from reservoir fluctuations. Visible incipient movements or cracks development in the dam abutments. Abrupt change in Power House(s) generating units performance independently from the operator of the plant (like abrupt reduction of turbined flow, turbine stop, energy production abrupt decrease)	Earthquake greater than OBE recorded through dedicated instruments. Fast by all. People and animals are alarmed, and many run outside. Furniture moves, and objects fall from walls and shelves. Damage to buildings.	Increasing rate of excessive leaks through local drain system. Seepage carrying fines detected through drains. Visible incipient movements or cracks development in visible portions of the works (Visible signs of structural failures of Intake Tower, or fillside Level Outlet, or gate shaft, surge shaft, spillway piers or chute). Abrupt change in hydraulic device performance independently from the operator of the plant (like abrupt reduction or variation of discharged flow) Excessive leaks through river diversion tunnels (through visual detection, if possible, considering they will be often submerged).	Scouring in the plunge pool attaining dam downstream toe exceeding depth corresponding to dam foundation bottom gallery level (not instrument available, specific monitoring check to be conducted if necessary). Visible movements or cracks in the dam body. Anomalous or abrupt displacements recorded through invert pendula or dam deformometers.	Spillway or HILO or Power Waterways gates unable to work in conjunction with possible flood events. Reservoir level trend raising above the maximum Operating Level.	Scouring in the plunge pool attaining dam downstream toe exceeding depth corresponding to dam foundation bottom gallery level (not instrument available, specific monitoring check to be conducted if necessary). Visible movements or cracks in the dam body. Anomalous or abrupt displacements recorded through invert pendula or dam deformometers.	Heavy rain forecast. Reservoir level records above Maximum Operating Level, but below dam crest level. Reservoir level trend raising. Spillway and fillside Level Outlets already fully opened or out of operation.	Attack that threatens the integrity of the dam or spillway or Power Waterways
Response Level I Conditions might lead to downstream flooding. Outside notification required	Drained flow in lower galleries approaches the pumps capacity limits. Leaks appears on dam downstream face through RCC horizontal lifts joints. Uncontrolled movements of portions of dam	Dam foundation subject to uncontrolled seepage or piping or displacements along main joints of the rock develops a major uncontrolled outflow or source of evident movements of the dam (or of a portion of it)	Abutment(s) rock subject to uncontrolled outflow or major uncontrolled outflow or source of evident movements of the rock wedges, power tunnel lining or dam body (or of a portion of it)	Instability of dam resulting from earthquake (centimetric abrupt displacements or movements recorded through pendula, deformometers and joint meters. Visible Cracks on dam body, strong increase of leaks through dam drains)	Left or right abutments subject to uncontrolled outflow or source of evident movements of the rock wedges or dam body (or of a portion of it). Middle Level Outlet structures subject to uncontrolled leaks or movements. Spillway structure subject to uncontrolled leaks or movements affecting the dam crest and/or its retention capacity. Reservoir level trend raising, predicted to exceed dam crest level.	Spillway or HILO or Power Waterways gates unable to work in conjunction with possible flood events. Reservoir level trend raising, predicted to exceed dam crest level.	Dam foundation at downstream toe subject to uncontrolled scouring or displacements along main joints of the rock developing a major uncontrolled source of evident movements of the dam (or of a portion of it)	Reservoir level trend raising, predicted to exceed dam crest level.	As above	
Response Level II Prepare for evacuation	Dam collapse imminent	Dam collapse imminent	Dam or power waterways or abutments rock collapse imminent	Integrity of dam visibly jeopardized by earthquake	Dam or power waterways or abutments rock collapse imminent. River diversion plugs failure imminent. Dam overtopping imminent.	Dam overtopping imminent	Dam collapse imminent	Dam overtopping imminent	As above	
Response Level III Evacuation is necessary	Dam collapse imminent	Dam collapse imminent	Dam or power waterways or abutments rock collapse imminent	Integrity of dam visibly jeopardized by earthquake	Dam or power waterways or abutments rock collapse imminent. River diversion plugs failure imminent. Dam overtopping imminent.	Dam overtopping imminent	Dam collapse imminent	Dam overtopping imminent	As above	

Table 25 – Response Level matrix

E.3.2 TYPE OF EMERGENCIES

A Dam Safety Emergency is an event that has the potential of endangering the integrity of the dam or appurtenant structures, and therefore requires immediate action.

A national civil emergency is an event that has been declared either a state of local emergency or a state of national emergency by one of these institutions:

- ZRA,
- a Zambian Provincial Authority
- a Zambian Government Minister
- a Zimbabwean Provincial Authority
- a Zimbabwean Government Minister

A national civil emergency may occur due to an extreme flood which the Batoka Dam Project passes without incident.

There are substantially three categories of Dam Safety Emergencies:

- Internal Emergencies:
- Developing Emergencies:
- Imminent Emergencies.

Internal Emergency is when there is no danger of a dam failure, but flooding is expected to occur downstream. It can be dealt with internally by the operators of the PMS at Batoka Plant and no outside notifications are required.

The response level for this category of emergency is called "Internal Alert".

Developing Emergency is used when a potential dam failure situation is developing. It occurs only when there is some time still available for further analysis/decisions or corrective measures before uncontrolled release of water. The dam condition may be deteriorating but it is not judged likely to fail within hours. Notification to third parties is required.

The response level for this category of emergency is called "Response Level I".

Imminent Emergency is used when failure of the dam is considered imminent or has occurred.

It is when "time has run out" - a failure has either occurred is occurring or about to occur. This condition is declared when there is no longer any time available to attempt corrective measures to prevent failure. The dam has or is in the process of failing or is expected to fail within hours rather than days. Immediate notification to third parties is required.

Within this category of emergency falls the "Response Level II", for the evacuation preparation, and the "Response Level III" for evacuation.

The response levels for the hazard events identified (also described in next chapter) at Batoka Plant are described in the Response Level Matrix above.

E.4 INITIATION OF THE EMERGENCY ACTION PLANS

E.4.1 HAZARD CONTEXT

A dam hazard is an issue or event that has the potential to impact on the safety of the dam and the consequences downstream that the dam might influence. A hazard may be a natural event such as an earthquake, a structural problem, or an operational issue such as sudden changes of water discharge.

The hazard events relevant to Batoka are identified as follows:

- Important leakages through dam and its foundations
- Important leakages through power waterways
- Earthquake event
- Water control devices structural failure
- Gate malfunction, equipment failure, loss of power supply, fire
- Excessive plunge pool scouring endangering dam foundations
- Extreme weather warning (Rainfall / major flood event)
- sabotage

Events that would initiate the emergency action plan are summarised in *Table 25 – Response Level matrix*.

E.3.1 EMERGENCY IDENTIFICATION AND EVALUATION

Emergencies that may develop into a Dam Safety Emergency are by nature unpredictable.

This means that the response to incidents cannot be prescribed in detail. However, once an incident has occurred it can be assessed and actions taken to control and mitigate consequences by following pre-established procedures.

The initial notification of an incident that may develop into a Dam Safety Emergency may come from a number of sources:

- Regional event (e.g. earthquake, flood) recorded by national or local authorities,
- Observation by a Batoka Plant PMS staff member on site,
- Values read from monitoring site instruments by Batoka PMS staff.
- Observations by PMS operators.

In all cases actions should be based on:

1. Secure your own safety.
2. Alert others in the immediate area.

3. Notify the PMS and the Owner(s), if the case, and advise location, seriousness and nature of emergency event.

On receiving notification of an incident, the PMS Operator assesses the seriousness of the incident. If the incident qualifies as an emergency, the PMS Operator will contact the PMS structure and the Owner(s) structure to cooperate in emergency management.

The PMS shall identify clearly the roles and responsibilities of those involved in emergency management. Some emergency events may require national government resources for assistance.

Contacts for notifications shall be reported in the formats provided at the end of this report, that shall be duly filled and always be updated by the PMS since the beginning of his work.

The PMS shall then develop, within its structure and the Plant Owner structure, specific flow charts for the notification process for the different cases of Imminent Emergencies notification and Developing Emergencies notification, as well as for the internal notifications applicable to an Internal Emergency.

In the redaction of such flow charts, the following general progressive steps (as far as necessary) shall be followed:

- 1) Check threshold for emergency: *Table 25*.
- 2) Document the emergency (circumstantiating at least the type and the location).
- 3) Notify to PMS and Owner(s) deputed structures. Only in the case of an internal emergency that are unlikely to have an impact on the downstream areas, the notification to the local authorities can be omitted.
- 4) The appropriate PMS personnel shall provide advice and support, and implement, if the case, the relevant Action Plan.
- 5) Consult external advice and support, if the case.

Whenever the emergency implies evaluations and actions out of the technical, political or decisional competence of the PMS personnel, external advice is required. As far as technical or dam safety matters are concerned, consultancy of qualified engineering advice shall be seek.

As far as the particular case of the seismic event, it is here recalled that the structure is located in a seismic region.

The Seismic Hazard assessment at feasibility design level is presented in dedicated report "320 SEI R SP 001 C - Seismic Hazard Assessment, February 2016", to which reference is made, from which the following PGA values have been retained for the design:

- | | | |
|----------|------------|---|
| - 0.23 g | | SEE (Safety Evaluation Earthquake) |
| - 0.08 g | RP = 475 | DEAS (Design Earthquake for Appurtenant Structures) |
| - 0.05 g | RP = 145 y | OBE (Operating Basis Earthquake) |

This assessment is assumed will be refined during the development of detailed design.

E.5 EMERGENCY RESPONSE AND ACTION PLANS

E.5.1 INITIAL RESPONSE AND EMERGENCY INSPECTIONS

The initial response by the PMS or Owner(s) departments that will be deputed to receive the notifications of the PMS staff operating on site, in the case of a notification of an emergency event, is to assess and confirm the extent of the emergency event to enable an appropriate course of action to be implemented.

The initial response may be a decision to immediately begin lowering the reservoir level.

If failure of the dam is considered not imminent, then the initial response will involve checking operational conditions. The Director of PMS will make immediate arrangements for site inspections to be carried out.

The purpose of the Emergency Inspection is to:

- Detect physical indicators of failure modes (Imminent or Potential Dam Failure);
- Detect physical indicators limiting/preventing drawdown functionality and capability.

Emergency Inspections shall be undertaken by Surveillance Inspectors in accordance with the appropriate Emergency Inspection Checklists reported in the next paragraph. The checklists define the observations to be made and reported to the Director of the PMS structure. The list provided for the checklists is a reference format that can be integrated by the PMS staff according to the need.

Despite the emergency inspection checklists is foreseen to be carried out as routine activity, it is illustrated below for sake of completeness. The observations gathered by the instruments monitoring and provided in the foreseen inspection reports shall be combined and correlated with the visual observations and records gathered by the emergency inspection.

E.3.2 EMERGENCY INSPECTIONS CHECKLISTS

The following pages provide the inspection checklists of the main works of the Plant. They can be integrated as appropriate by the PMS.

The observations of this check shall be always correlated and integrated with the check and data available from the dam instruments.

Dam (Sheet 1 of 2)			
Emergency Inspection Checklist			
Go to Main Dam Left and Right Abutments and compare condition with photographs			
Check		Change Yes/No	Comments
Reservoir	Reservoir level steady	Y/N	
	Unusual flow patterns	Y/N	
	Landslides in reservoir surrounds	Y/N	
Insert photograph of reservoir in normal condition			
Check		Change Yes/No	Comments
Dam face upstream	Damages or cracks in the visible part of dam u/s face	Y/N	
	Damages at Dam-rock contact	Y/N	
	Any right abutment damage, slides, sink holes, depressions, erosion etc.	Y/N	
	Any left abutment damage, slides, sink holes, depressions, erosion, etc	Y/N	
	Leaks inside dam galleries	Y/N	
	Leaks from Waterstop drains	Y/N	
	Is water line against upstream face a straight line?	Y/N	
Dam Crest	Any damage, cracks, depressions etc	Y/N	
Dam bottom	Leaks inside dam galleries and possible foundations seepage	Y/N	
Insert as far as of interest photographs of upstream area, right abutment and left abutment.			
The observations of this check shall be integrated with the check and data available from the dam instruments.			

Table 26 – EMERGENCY CHECKLIST 1 sheet 1 of 2 - Dam

Dam (Sheet 2 of 2)		
Emergency Inspection Checklist		
Insert photograph of reservoir in normal condition		
Check	Change Yes/No	Comments
Dam downstream face	Leaks through RCC	Y/N
	Cracks on dam d/s face	Y/N
	Damage or sign of movements or cracks at Dam- rock contact	Y/N
	Any right abutment damage, slides, sink holes, depressions, erosion, water venues, signs of movements, etc.	Y/N
	Any left abutment damage, slides, sink holes, depressions, erosion, water venues, signs of movements, etc.	Y/N
	Seepage	Y/N
Insert photo showing right abutment downstream detail	Insert photo showing downstream toe detail	Insert photo showing left abutment downstream detail
Report to PMS general condition of dam and toe.		
Time and date of inspection:		
Inspector name:		
Received by PMS (date and time):		Operator Name:
Notified to: _____ in date: _____		by: _____

Table 27 – EMERGENCY CHECKLIST 1 sheet 2 of 2 - Dam

Spillway			
Emergency Inspection Checklist			
Go to Spillway and compare condition with photographs			
Check		Change Yes/No	Comments
Reservoir	Reservoir level steady	Y/N	
	Unusual flow patterns	Y/N	
	Landslides in the reservoir	Y/N	
	Clogging of spillway gates by trunks	Y/N	
	Recent floods occurred	Y/N	
Insert photograph of reservoir in normal condition			
Check		Change Yes/No	Comments
Spillway gates	Visible damages or blockage of gate/s	Y/N	
	Any damage or leaks or wetting in the gates concrete piers	Y/N	
	Any visible movement of a gate concrete pier	Y/N	
	Leaks from gate itself or evident damages to the oleodynamic unit	Y/N	
Spillway chutes	Damages or cracks or cavitation in the visible part of concrete	Y/N	
	Aerators clogged or damaged	Y/N	
Spillway drains	Any unusual or important leakages	Y/N	
Insert as far as of interest photographs.			
The observations of this check shall be integrated with the check and data available from the dam instruments.			
Report to PMS general condition of dam and toe.			
Time and date of inspection:			
Inspector name:			
Received by PMS (date and time):		Operator Name:	
Notified to:	in date:	by:	

Table 28 – EMERGENCY CHECKLIST 2 - Spillway

Power Waterways (applicable for each power waterway)			
Emergency Inspection Checklist			
Go to Power Waterways Drain Tunnels and compare condition with photographs			
Check		Change Yes/No	Comments
Reservoir	Reservoir level steady	Y/N	
	Unusual flow patterns	Y/N	
	Landslides or instable wedges on left abutment downstream of dam	Y/N	
	Recent floods occurred	Y/N	
Insert photograph of reservoir in normal condition			
Check		Change Yes/No	Comments
Shotcrete Lining	Damages or cracks in the visible part of lining	Y/N	
	Any abutment damage, slides, sink holes, depressions, erosion, etc	Y/N	
	Leaks through fissures in rock or shotcrete (not from drain holes)	Y/N	
	Leaks from Watertight doors	Y/N	
Drains	Any unusual or important leakages	Y/N	
	Any drains obstruction or clogging	Y/N	
Insert as far as of interest photographs. The observations of this check shall be integrated with the check and data available from the dam instruments.			
Report to PMS general condition of dam and toe.			
Time and date of inspection:			
Inspector name:			
Received by PMS (date and time):		Operator Name:	
Notified to:	in date:	by:	

Table 29 – EMERGENCY CHECKLIST 3 – Power Waterways

Gate Shafts Intakes (applicable for each power waterway)			
Emergency Inspection Checklist			
Go to Gates shafts and compare condition with photographs			
Check		Change Yes/No	Comments
Reservoir	Reservoir level steady	Y/N	
	Unusual flow patterns	Y/N	
	Landslides or instable wedges on left abutment downstream of dam	Y/N	
	Recent floods occurred	Y/N	
Insert photograph of reservoir in normal condition			
Check		Change Yes/No	Comments
Gate shaft	Visible damages or cracks or movement of the visible part of lining, including upper room	Y/N	
	Any abutment damage, slides, sink holes, depressions, erosion, etc	Y/N	
	Leaks through fissures in the shaft	Y/N	
Gates	Visible damages or blockage of gate/s	Y/N	
	Any blockage or problem to lifting devices	Y/N	
Insert as far as of interest photographs.			
The observations of this check shall be integrated with the check and data available from the dam instruments			
Report to PMS general condition of dam and toe.			
Time and date of inspection:			
Inspector name:			
Received by PMS (date and time):		Operator Name:	
Notified to:		in date: by:	

Table 30 – EMERGENCY CHECKLIST 4 – Gate Shafts (Intake)

Surge Shafts (applicable for each power waterway)			
Emergency Inspection Checklist			
Go to Surge shafts and compare condition with photographs			
Check		Change Yes/No	Comments
Reservoir	Reservoir level steady	Y/N	
	Unusual flow patterns	Y/N	
	Landslides or instable wedges on left abutment downstream of dam	Y/N	
	Recent floods occurred	Y/N	
Insert photograph of reservoir in normal condition			
Check		Change Yes/No	Comments
Surge shaft	Visible damages or cracks or movement of the visible part of lining, including upper structure	Y/N	
	Any abutment damage, slides, sink holes, depressions, erosion, instable wedges, leaks, etc	Y/N	
	Leaks through fissures in the shaft	Y/N	
	Any anomaly in functioning of turbines operation	Y/N	
Drains	Any unusual or important leakages through fissures in the surrounding rock or in drains	Y/N	
	Any drains obstruction or clogging	Y/N	
Insert as far as of interest photographs.			
The observations of this check shall be integrated with the check and data available from the dam instruments			
Report to PMS general condition of dam and toe.			
Time and date of inspection:			
Inspector name:			
Received by PMS (date and time):		Operator Name:	
Notified to:		in date: by:	

Table 31 – EMERGENCY CHECKLIST 5 – Surge Shafts

MIDDLE LEVEL OUTLETS and PLUNGE POOL			
Emergency Inspection Checklist			
Go to MLOs and PLUNGE POOL and compare condition with photographs			
Check		Change Yes/No	Comments
Reservoir	Reservoir level steady	Y/N	
	Unusual flow patterns	Y/N	
	Recent floods occurred	Y/N	
Plunge Pool	Landslides or instable wedges on plunge pool abutments	Y/N	
Middle Level Outlets	Odd or exceptional MLO operation event	Y/N	
Insert photograph of reservoir in normal condition			
Check		Change Yes/No	Comments
Plunge Pool	Visible damages or cracks or movement of the visible part of left abutment deflecting wall.	Y/N	
	Any front of excavation visible damages, slides, sink holes, erosion, instable wedges, leaks, shotcrete cracks, etc	Y/N	
	Scoured material invading and obstructing the PH tailrace	Y/N	
MLO	Blockage or serious visible damage of: Upstream gate Downstream gate Steel lining Downstream concrete block structure Protection slab at dam downstream toe Control room	Y/N	
	Visible damages to Control units or control cables of hydraulic devices	Y/N	
Insert as far as of interest photographs.			
The observations of this check shall be integrated with the check and data available from the dam instruments.			
Report to PMS general condition of dam and toe.			
Time and date of inspection:			
Inspector name:			
Received by PMS (date and time):		Operator Name:	
Notified to:		in date: by:	

Table 32 – EMERGENCY CHECKLIST 6 – MLO and Plunge Pool

Power House (applicable to each power house)			
Emergency Inspection Checklist			
Go to Power House and compare condition with photographs			
Check		Change Yes/No	Comments
Reservoir	Reservoir level steady	Y/N	
	Unusual flow patterns	Y/N	
	Recent floods occurred	Y/N	
Power House	Landslides or instable wedges on power house excavation front	Y/N	
	Odd or exceptional units operation	Y/N	
Insert photograph of reservoir in normal condition			
Check		Change Yes/No	Comments
Power House	Visible damages or cracks or movement of the visible part of structure, including external buildings	Y/N	
	Any front of excavation damage, slides, sink holes, erosion, instable wedges, leaks, etc	Y/N	
	Leaks through PH structure concrete	Y/N	
Hydraulic or control devices	Blockage or serious damage of: Generation unit Transformers MIVs Ecological Valves Draft tube gates Drain pumps Control room	Y/N	
	Visible damages to OHL transmission lines	Y/N	
Insert as far as of interest photographs.			
The observations of this check shall be integrated with the check and data available from the dam instruments.			
Report to PMS general condition of dam and toe.			
Time and date of inspection:			
Inspector name:			
Received by PMS (date and time):		Operator Name:	
Notified to:		in date: by:	

Table 33 – EMERGENCY CHECKLIST 7 – Power House

Instrumentation (applicable to each instrument)			
Emergency Inspection Checklist			
Go to Power House and compare condition with photographs			
Check		Change Yes/No	Comments
Reservoir	Reservoir level steady	Y/N	
	Unusual flow patterns	Y/N	
	Recent floods occurred	Y/N	
Power House	Landslides or instable wedges on power house excavation front	Y/N	
	Odd or exceptional units operation	Y/N	
Insert photograph of reservoir in normal condition			
Check		Change Yes/No	Comments
Power House	Visible damages or cracks or movement of the visible part of structure, including external buildings	Y/N	
	Any front of excavation damage, slides, sink holes, erosion, instable wedges, leaks, etc	Y/N	
	Leaks through PH structure concrete	Y/N	
Hydraulic or control devices	Blockage or serious damage of: Generation unit Transformers MIVs Ecological Valves Draft tube gates Drain pumps Control room	Y/N	
	Visible damages to OHL transmission lines	Y/N	
Insert as far as of interest photographs.			
The observations of this check shall be integrated with the check and data available from the dam instruments.			
Report to PMS general condition of dam and toe.			
Time and date of inspection:			
Inspector name:			
Received by PMS (date and time):		Operator Name:	
Notified to:	in date:	by:	

Table 34 – EMERGENCY CHECKLIST 8 – Instrumentation

E.5.2 EMERGENCY ACTION PLANS

The following principles underlie the emergency actions for all dam safety emergencies.

- **PERSONNEL SAFETY** must be considered **FIRST** at all times.
- The primary defence if failure of the Batoka Dam is developing or if the dam is seriously damaged, is to **LOWER THE RESERVOIR**. This is achieved by means of Spillway and/or Middle Level Outlet devices, conjunctively with the Powerhouses units if available, as described in the next chapters of this part. The extent to which it should be lowered depends on the reason for the emergency. Advice should be taken from an experienced dam safety engineer in the Hydropower Development and Dam administration directorate.
- However, if the emergency is related to damage to the Power Waterways downstream of the Gate shafts, then this action should not be forcedly taken and the **GATES SHOULD BE CLOSED** in order to isolate the damaged area. The same in case of damage to Middle Level Outlets, relevant gates shall be closed to isolate the problem.

Emergency Action Plans shall be developed to cover the situations that could lead to the development of failure modes for the dam and the associated critical structures relevant to initiating events reported in table *Table 25* and recalled in the following table.

The plan shall be developed in order to foresee the implementation of a stepped notification procedure, following the above principles and the guidelines of table *Table 25*, to be applied on case by case basis to the emergency.

A typical Action Plan is reported in next figure. Emergency Action Plans have been developed to cover the situations that could lead to the development of failure modes for the dam and the associated critical structures diagrammatically one by one in the subsequent figures.

INITIATING EVENT (ref. table at par. E.3.1)	Failure Mode	Description of failure mode
1a Excessive leakage through dam	FM 1a	Drained flow in lower galleries approaches the pumps capacity limits. Leaks appears on dam downstream face through RCC horizontal lifts joints. Uncontrolled movements of portions of dam
1b Excessive uplift pressures or excessive seepage/piping through dam foundations	FM 1b	Dam foundation subject to uncontrolled seepage or piping or displacements along main joints of the rock develops a major uncontrolled outflow or source of evident movements of the dam (or of a portion of it)
2 Excessive leakage through power waterways or left or right abutment	FM 2	Leaks of Power Waterways Left abutment subject to uncontrolled leaks, developing major uncontrolled outflow or source of evident movements of the rock wedges, power tunnel lining or dam body (or of a portion of it)
3 Earthquake	FM 3	Loss of freeboard or impairment of integrity of dam crest and spillway structure due to earthquake shaking
4 Structural failure of devices for water control (Middle Level Outlets, Spillway, Power Waterways, Power Houses, River diversion plug)	FM 4	Left or right abutments subject to uncontrolled leaks, developing major uncontrolled outflow or source of evident movements of the rock wedges, power or diversion tunnel linings or dam body (or of a portion of it). Middle Level Outlets structures subject to uncontrolled leaks or movements. Spillway structure subject to uncontrolled leaks or movements affecting the dam crest and/or its retention capacity. Reservoir level trend raising, predicted to exceed dam crest level. Structural failure of Intake tower(s). Blockage of power tunnel intake(s) opening, Obstruction of Power Waterways intake(s).
5 Gate failure/ power loss/ equipment failure/ fire	FM 5	Spillway or MLOs or Power Waterways gates unable to work in conjunction with possible flood events. Reservoir level trend raising, predicted to exceed dam crest level.
6 Excessive plunge pool scouring endangering dam foundations	FM 6	Dam foundation at downstream toe subject to uncontrolled scouring or displacements along main joints of the rock developing a major uncontrolled source of evident movements of the dam (or of a portion of it).
7 Extreme weather warning	FM 7	Reservoir level trend raising, predicted to exceed dam crest level.
8 Sabotage/ accident	FM 8	Attack that threatens the integrity of the dam or spillway or Power Waterways

Table 35 – Failure modes for Action Plans

ACTION PLAN TYPICAL GRAPH

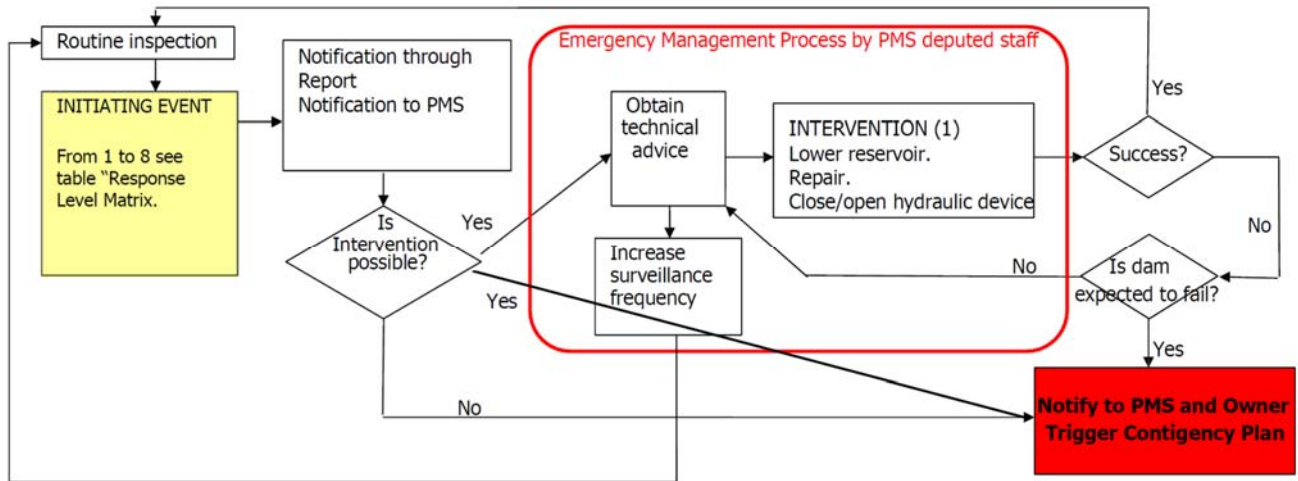

(1) The type and extent of the intervention shall be identified according to the case, taking into account the principles above indicated and in any case through the advice taken from an experienced dam safety engineer. In the next graphs the interventions for the main initiating events are shown. For Power Waterways and power house they are referred to the left abutment, but shall be considered as typical for both power plants.

Action Plan 1 – Leaks or seepage through Dams, Foundations or Abutments

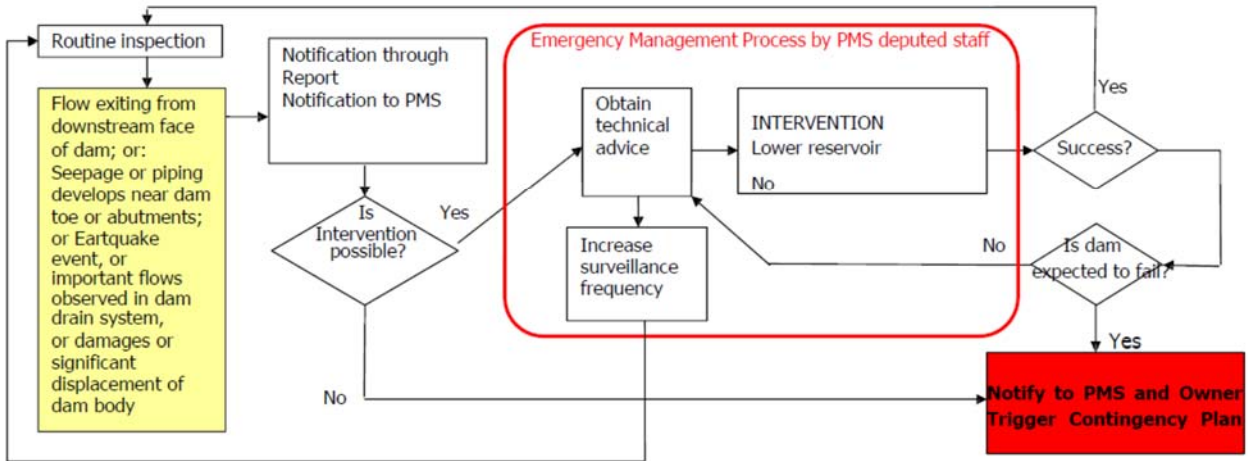

Action Plan 2 – Leaks of Power Waterways or seepage through left abutments

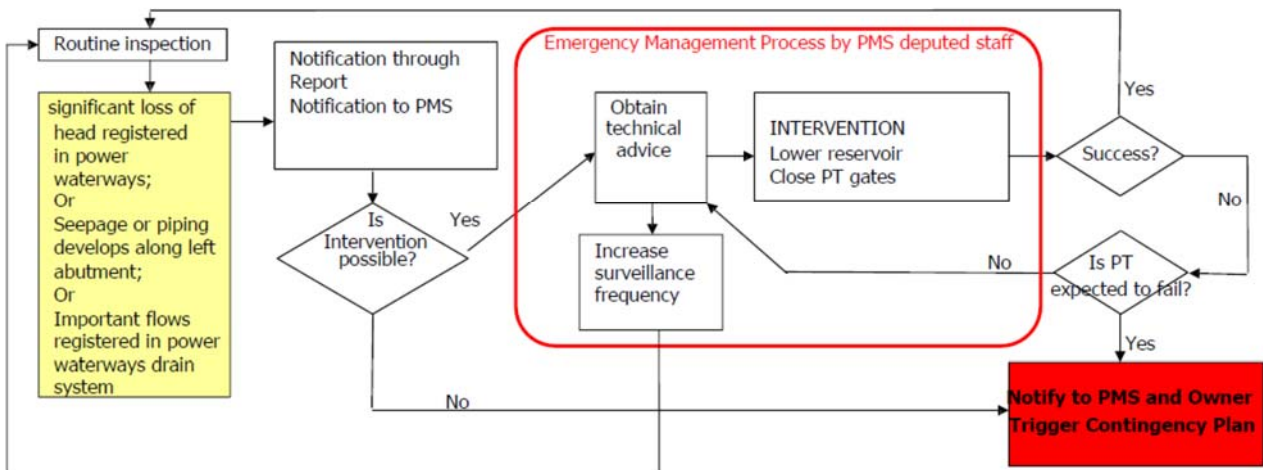

Action Plan 3 – Dam overtopping

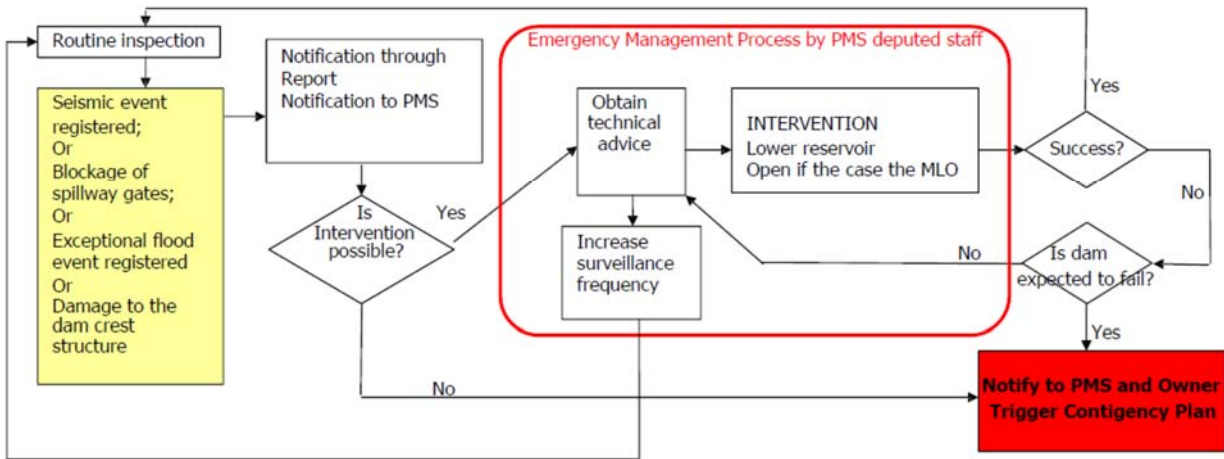

Action Plan 4 – Power Waterways inlet failure

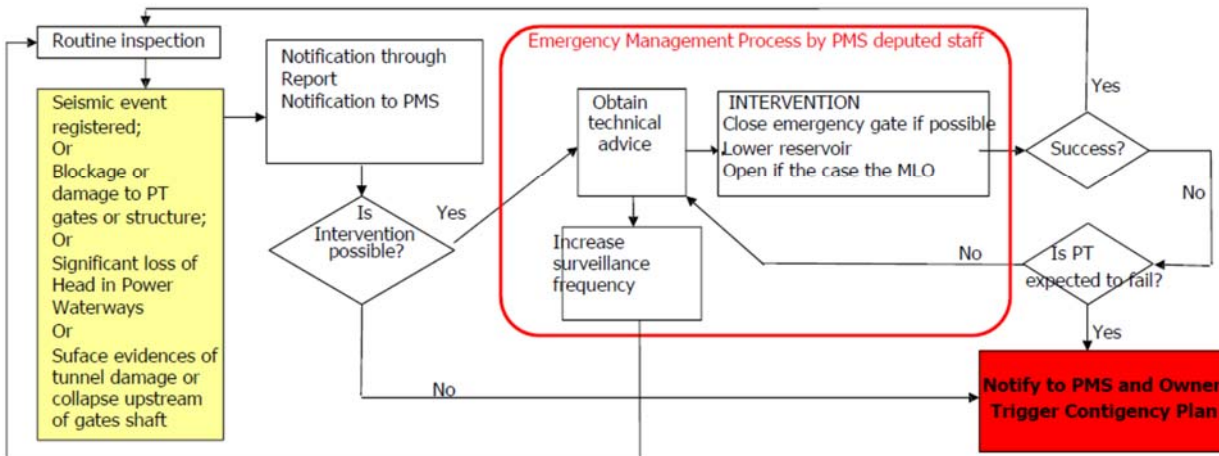

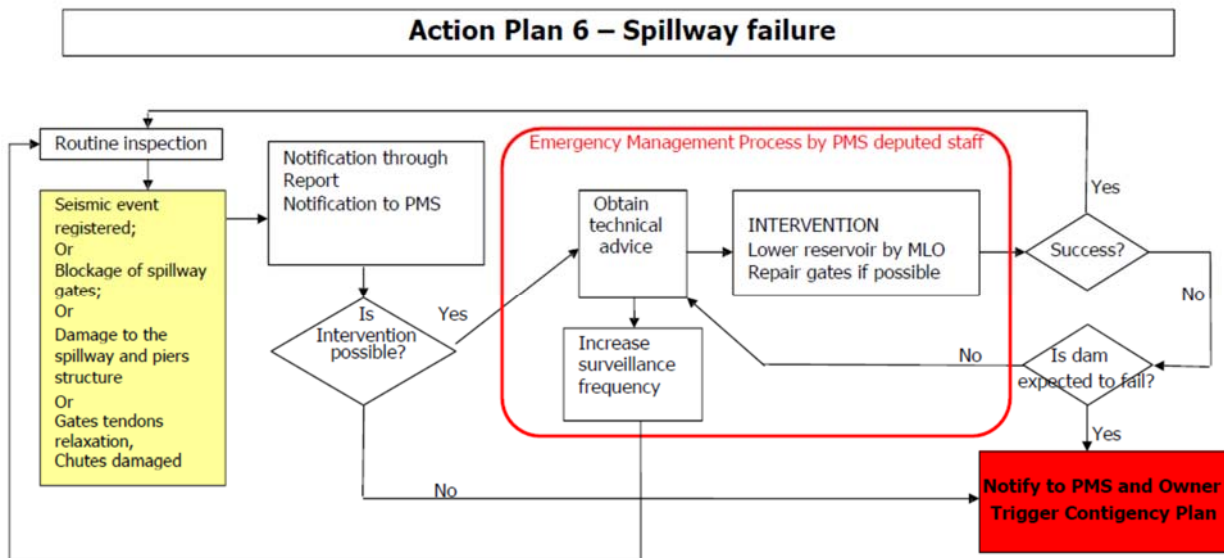
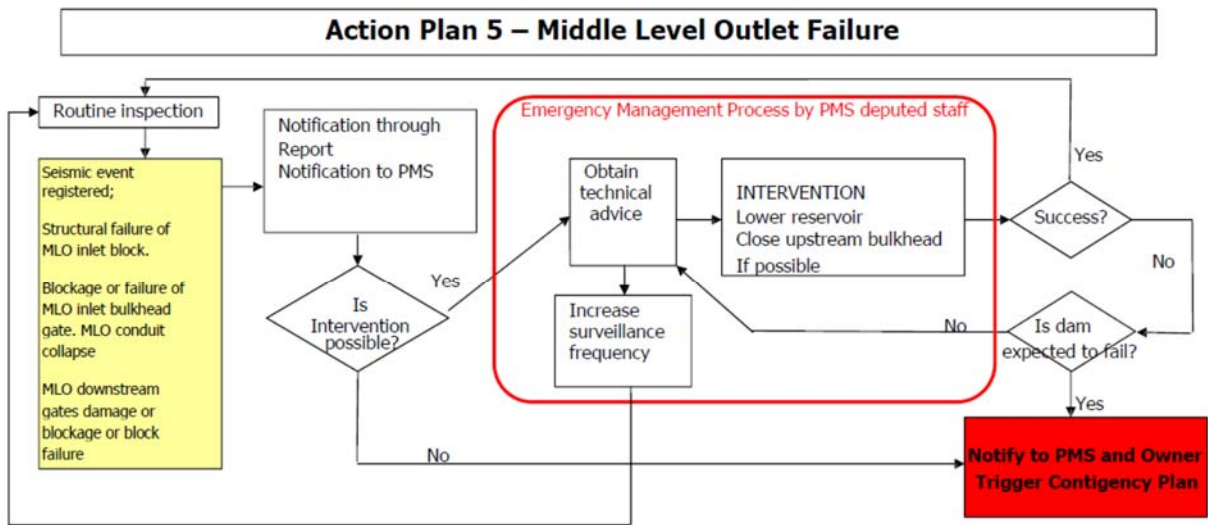

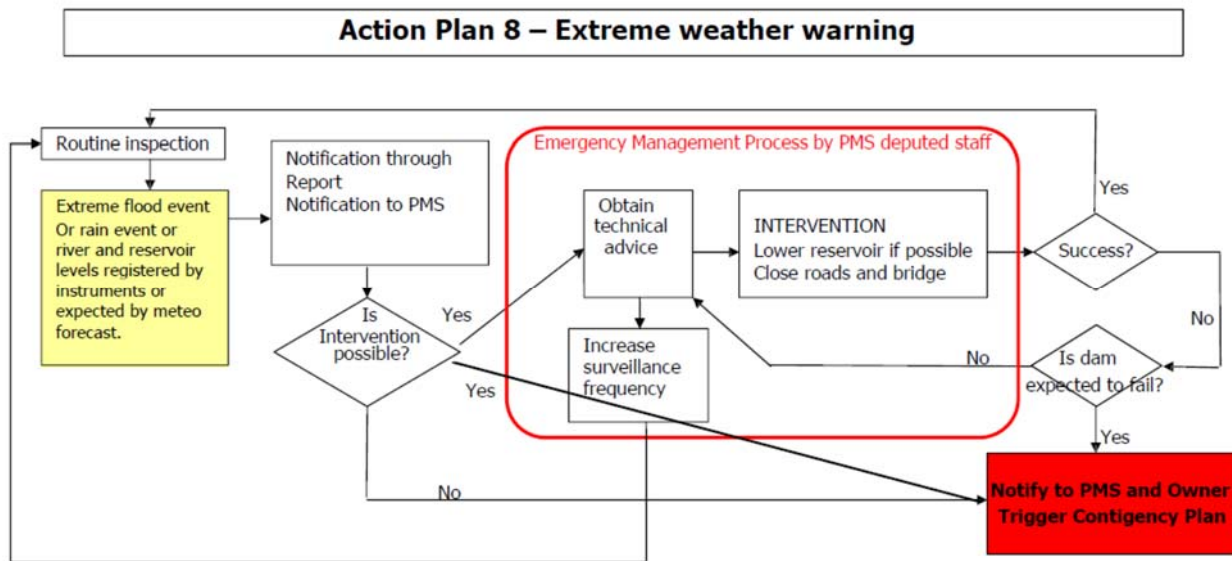
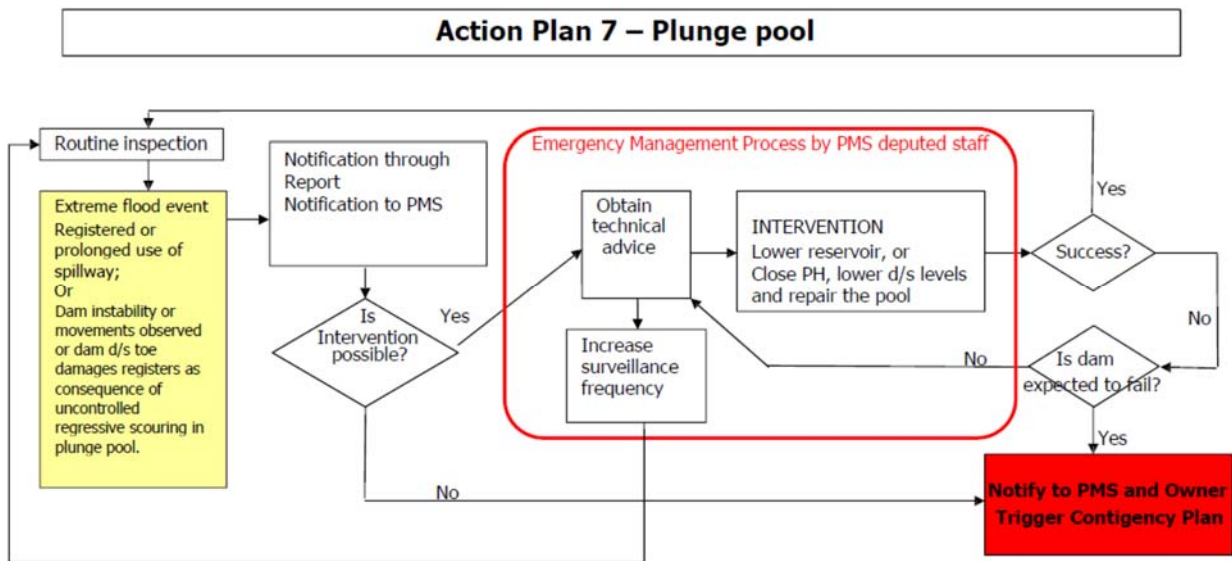

E.6 PREPAREDNESS PLAN IMPLEMENTATION

E.6.1 ACCESS ROUTES – PRIMARY AND SECONDARY

Direct access roads to the Batoka dam and power houses are designed, at feasibility design level, coming from the nearest available roads and villages, as indicated in relevant drawings of the Feasibility Design (from which the next figure is extracted).

They are assumed to be developed and finalized at further detailed design stage.

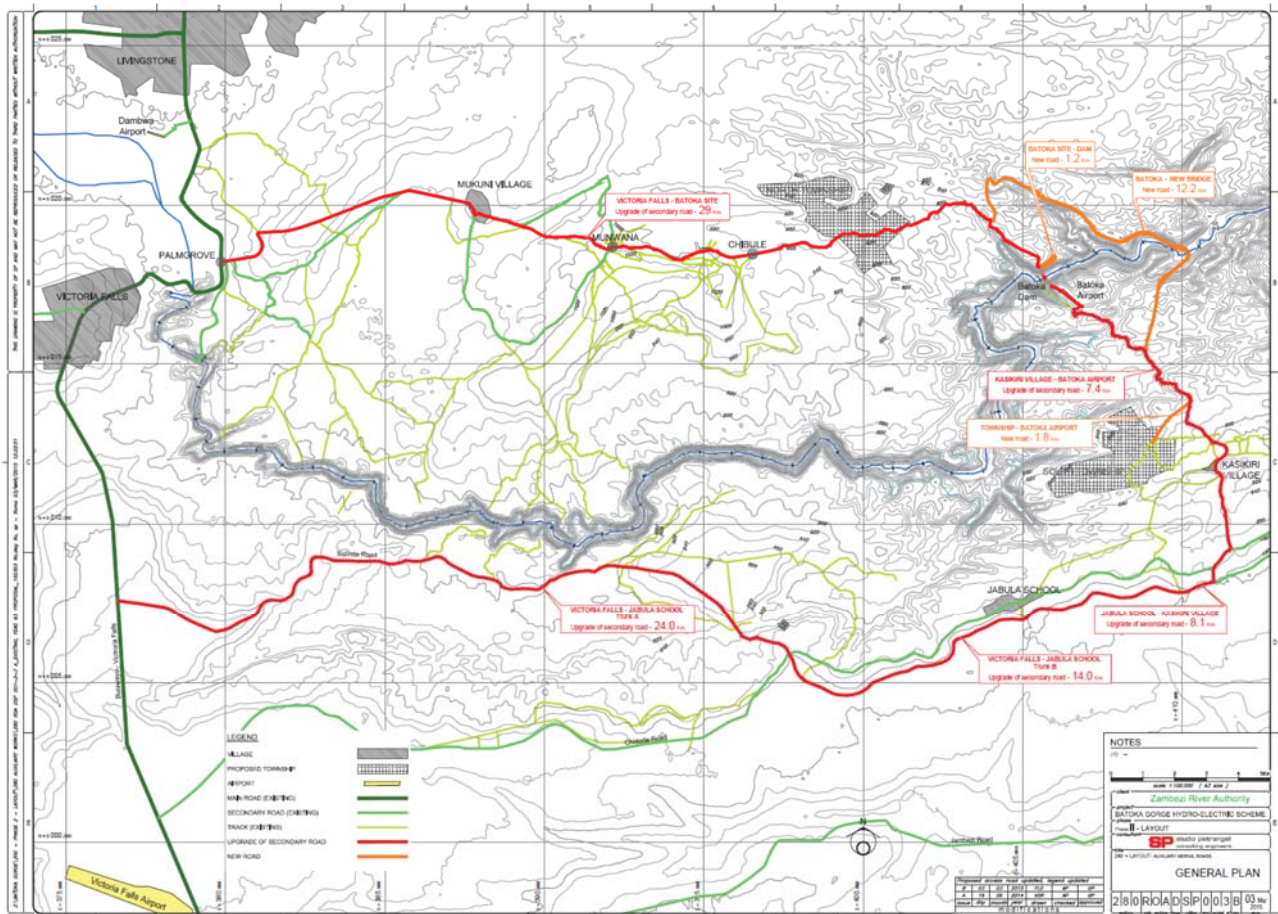

A site map showing the location and main access routes to the dam, control buildings, Power House and other site structures shall be kept updated and attached to this RPP.

Access using bike or motorbike, or on foot, may be required under emergency circumstances if roads are impassable in usual vehicles. Access difficulties are likely if roads are damaged by earthquake or flood.

E.6.2 PUBLIC SAFETY

Public access to Batoka site (dam, power houses, switchyards) is assumed will be restricted using gates and fences as appropriate.

Access to the dam crest, intake tower and outlet areas will be restricted using gates and fences as appropriate.

E.6.3 SITE SECURITY

A security plan for the dam should be prepared and implemented by the PMS, considering the following aspects: dam size, location, hazard classification, importance to the economy, national defence and local public order.

In this regard, for the case of Batoka Plant, it shall be considered that:

- the dam size is very big,
- the location is impervious, but not extremely remote in respect to the main towns and roads of the country,
- the region downstream Batoka Plant is not uninhabited, but along the river it is not occupied by major townships,
- the plant is of great importance for the economy of the country.
- the plant has an international interest, being of transboundary nature and inserted in the network of neighbour countries.
- The plant is not far from Victoria Cascades, that is an international site attracting international visitors every year.

The plan shall identify the roles and responsibilities for site security and management of the reservoir area.

The following site areas should be in principle restricted and fenced off:

- Dam
- Dam abutments yard (in a zone of at least 100m beyond the abutments)
- Gate shafts intakes and relevant accesses
- Plunge Pool and relevant abutments, for a stretch of the river of at least 1km downstream.
- Surge shafts and relevant yards
- Accesses to access tunnels along the Power Waterways
- Power Houses (double fence shall be foreseen in the energized area of the HV transformers)
- Switchyards
- Control buildings and diesel generator buildings,
- River diversion (as far as applicable in consideration of the temporary nature of such work).

E.6.4 ON SITE RESOURCES

A security plan for the dam should be prepared and implemented by the PMS, considering the following aspects.

It is important to maintain sufficient resources on the site in order to swiftly handle emergencies if access to the dam is restricted. It is assumed that Batoka dam is continuously manned and that there are sufficient numbers of people living near the site to assist in carrying out emergency repairs.

Every incident is different and it is not possible to provide resources for every eventuality. The items listed in Table here below (that is indicative and can be integrated by PMS according to the need) are the basic resources that should be available to allow repairs to be carried out for the most likely incidents.

Early detection of emergencies can often restrict the emergency to an Internal Emergency and prevent it progressing to a Developing or Imminent Emergency. Therefore it is important to carry out routine dam safety surveillance by Batoka Project inspectors based at the dam.

<i>Resources</i>	<i>Location</i>
IMPORTANT EMERGENCY TOOLS	
Emergency communication system (such portable phones or radio)	
equipment Back-up power supplies	
Earthmoving equipment	
Drilling device for emergency small drain holes need	
Mobile crane	
Boat with engine	
BASIC EMERGENCY TOOLS	
Mobile floodlights and Torches	
First aid kit	
Welding Equipment	
Products for concrete crack sealing	

This list does not include ordinary spare parts assumed to be already available in the plant according to the project design.

Table 36 – Available emergency tools

E.6.5 CONTROLLED DRAWDOWN PROCEDURE

If deemed necessary, according to the analysis of the results of observations carried out during the surveillance inspections (as described in Operation and Maintenance Manual), the Controlled Drawdown Procedure or the Emergency Drawdown Procedure will be activated.

The Controlled Drawdown Procedure (CDP) is finalized to lowering the reservoir level without causing damages to the outlet structures such as Spillway, Power Waterways and Middle Outlets.

If according to the results of observations carried out during the Alert Procedure, an emergency state is triggered but any impending failure is excluded, the Controlled Drawdown Procedure will be activated to perform inspections and repair works on the submerged structures as necessary and as possible (no dewatering is physically possible below the operating range of the MLOs once reservoir is impounded).

This is of course valid only for impounding reservoir water levels above the operating range of the MLOs, and with the limits depending on the capacity of the available discharging devices versus the incoming flows (therefore also depending on the season and on the duration of the emergency state).

The reservoir drawdown is foreseen to inspect lower portions of dam upstream face, or the first portion of Power Tunnels upstream of the gate shafts.

The reservoir drawdown operations shall be carried out according to specific procedures that will be defined during the frame of the detailed design of the hydraulic structures.

The reservoir will be lowered, according to the water levels available in the reservoir within the minimum and maximum operating levels and to the Plant Operator choice, by means of:

- the Powerhouses units in operation (if at least one is maintained in operation 24 hours per day),
- the Ecological Discharge Device.
- the Spillway,
- the Middle Outlets.

E.6.6 EMERGENCY DRAWDOWN PROCEDURE

If the results of observations highlight an impending hazard for the dam safety, the Emergency Drawdown Procedure will be carried out in accordance to the instructions of the Contingency Plan described in the next chapter.

E.6.7 INFORMATION TO THE PEOPLE LIVING IN THE RESERVOIR AREA

- The population living in the zone of the impounding and downstream of the dam shall be informed about the reservoir regulation procedure, and in particular about the expected reservoir levels during normal and exceptional scenarios of operation (not only during the impounding period).
- Reservoir shore line will be marked on the ground in correspondence of roads, villages and other significant accessible points, with clear benchmarks or other evident signals on the shore line corresponding to the Maximum Operating Level, in order to give to the Owner(s) of the Plants and local Authorities a clear reference along the shoreline of the reservoir, for the operations of information and management of the ground that the Owner(s) will conduct.
- A program shall be implemented and provided by the PMS defining time and procedures required to inform the populations downstream of the Batoka dam of the artificial floods release whenever they are released from Middle Outlets and or from Spillway gates. This program will remain valid to be used during the current operation of the Plant, and updated in case it will be changed.
Downstream areas shall be informed also in case of any sudden release of water is decided through the operation of the Batoka Hydraulic devices (Middle Outlets, Spillway, Power Waterways), and they shall be coordinated with the downstream plant of Kariba.

E.7 CONTINGENCY PLAN

E.7.1 INTRODUCTION

For the RCC dam the risk of failure is extremely unlikely. At the same time, sudden release of stored water is a risk that can occur for exceptional flood events or accidental manoeuvre of hydraulic devices (Spillway, Power Tunnels and MLOs gates).

E.7.2 IMPENDING FAILURE OR FAILURE

IMPENDING FAILURE

If, during the period of the impounding or during the operation of the plant, there is a suspect of impending failure, or phenomena that can compromise the safety of the main structures (Dam, Power Waterways and relevant Shafts, Power Houses or other main structures) or adjacent natural or excavated slopes, the following procedures must immediately be initiated:

- 1 Contact and inform the Project Head Offices.
Contacts are reported in the forms at the end of this Part. They shall be filled and maintained updated by the PMS.
- 2 Inspect and monitor the dam (or other interested) structure and hydraulic steel structures.
- 3 Determine additional immediate actions in accordance with the Project Management Structure offices to be taken to reduce the risk of failure and any other necessary further actions.
- 4 In case it is decided to proceed with the partial drawdown of the reservoir, and if and if there are not the conditions to implement a controlled drawdown procedure described in this report at par. E.6.5 CONTROLLED DRAWDOWN PROCEDURE, coordinate efforts with the Owner and the Local Authorities in alerting all downstream areas of the rapid increase of releases (procedures for Large or sudden releases downstream of the dam).

FAILURE

If the Dam, or part of it, is failing, notice shall be immediately given by radio or by phone to the Owner(s) Head Office (see contacts at the end of this report), and simultaneously to Local Authorities (local police and municipalities, emergency evacuation units or mobile alarm team to be sent on the critical zones) that will take actions to trigger alarm and evacuation plans on the downstream areas, considering the areas susceptible of inundations as individuated in Dam Break Analysis document (see following chapter), whose final version is

assumed will be prepared in detailed design stage and relevant maps included in this volume for easy of consultation.

The detailed procedure for implementation of this notice shall be developed by the PMS. It shall be developed considering the transboundary nature of the Project, the structure of Ownership and Operation that will have this plant, as well as the need to coordinate any important decision about water management with the downstream plant of Kariba.

E.7.3 LARGE OR SUDDEN RELEASE DOWNSTREAM OF THE DAM

EMERGENCY DRAWDOWN

In case a large water release downstream of the dam is imminent due to the actuation of the Emergency Drawdown of the reservoir the following procedure shall be followed:

- 1 the people working on site (if any) shall be immediately informed, and the working areas downstream of the dam close to the river evacuated;
- 2 trigger the "Large water release" alarm;
- 3 Employer and Local Authorities that control the critical zones shall be immediately contacted (see contacts at the end of this report) and informed.

ACCIDENTAL MANOEUVRE OF THE OUTLET GATES

In case of large and sudden water releases due to an accidental manoeuvre of the radial gates of the spillway, which cannot be closed within 15 minutes, the "Large water release" alarm shall be triggered and the Operator and Owner's Head Office informed (see contacts in the last paragraph of this report).

"LARGE WATER RELEASE" ALARM

The alarm is used in case of:

- Opening of the radial outlet gate during exceptional flooding.
- Opening of the Spillway and Middle Outlet gates for Reservoir Emergency Drawdown.
- Accidental opening of the spillway gates (according to procedure in previous paragraph).
- Impending danger of overtopping: the alarm is risen on the basis of the water elevation in the reservoir. Such event is extremely unlikely..

The alarm shall be triggered in order to assure at least 6 hour for the evacuation of the people working on site.

The alarm is given through notice the PMS and Owner Head Offices (see contacts reported in last paragraph of this report), that in turn will contact the Local Authorities (local police and municipalities, emergency evacuation units or mobile alarm team to be sent on the critical zones) to take immediate action in alerting populations and managing the emergency in the critical zones.

E.7.4 CONTACTS FOR EMERGENCY or ALARM CASES

In case of need to trigger an ALARM condition, or in case of need to implement an exceptional operation described in this part of the report, the addresses reported here below shall be immediately contacted:

Plant Management Structure				
Name	Position	Telephone	E-mail	Mail address

Local/Governmental Authorities				
Name	Position	Telephone	E-mail	Mail address

Table 37 – Contacts for Emergency or Alarm cases

E.8 DAM BREAK ANALYSIS

E.8.1 INTRODUCTION

The present chapter describes the results of the hydraulic calculations carried out to identify the flooded areas in case of emergency.

The Terms of Reference of the assignment at paragraph A.3.3.2 states that:

The Consultant shall carry out one-dimensional dam-break analysis and assess the downstream impact of such failure. The results of the dambreak analysis will be used to prepare inundation maps ...".

Purpose of this chapter is to provide the inundation maps as a result of the hydraulic calculation carried out for the dam break analysis.

In detail, the evaluation of the flooded areas located downstream of the Batoka dam has been carried out accordingly to the following scenario:

- DAM BREAK - Incoming of an extreme climate event meteorological event, which causes dam overtopping. This scenario has been evaluated on the base of the following foresees assumptions:
 - incoming of the PMF hydrograph while the reservoir is at full supply level (w.l. = 757 m asl);
 - flap gates blocked in the closed position (i.e. raised and retaining the upstream reservoir at OL max);
 - raising of the reservoir up to overtopping of the dam crest (crest level = 762 m asl);
 - almost instantaneous breach formation with consequent break of the entire dam.

This scenario assumes catastrophic characteristics and, as it will be further explained, capable of producing a flood event with peak discharge equal to approximately 803'870 m³/s.

Hydraulic analysis, which has been carried out using the HEC-RAS program, allowed to identify areas subject to flooding and to determine the hydraulic levels reached in the downstream areas of the project, the average speed of the water as well as the travel time of flood peak.

The study of the flood propagation has been analyzed for a river stretch of approximately 120 km length, along the Zambezi river, from the Batoka dam to the Lake Kariba.

The inundation maps that show the results of the dam break analysis are illustrated in the following annexed drawings:

- 346 DBK D SP 001 Inundation area, General, 300k
- 346 DBK D SP 002 Inundation area, Key map, 300k

- 346 DBK D SP 003 Inundation area, plan 100k , sheet 1 of 4
- 346 DBK D SP 004 Inundation area, plan 100k , sheet 2 of 4
- 346 DBK D SP 005 Inundation area, plan 100k , sheet 3 of 4
- 346 DBK D SP 006 Inundation area, plan 100k , sheet 4 of 4

E.8.2 TOPOGRAPHIC DATA

Modeling of water propagation over complex topographical surfaces for floodway delineation requires an accurate and reliable topographical database; for this report's aim, the following digital elevation models of the terrain were used:

- LIDAR (LASER SCANNING) with an resolution of 0.3 m;
- SRTM (Shuttle Radar Topography Mission) with an resolution of 30 m;

The LIDAR DTM is the most accurate among the two adopted digital models, and covers the main Zambezi river channel and close surroundings. In order to allow a complete floodplain delineation the LIDAR has been joined with the SRTM DEM, following the FEMA guidelines.

The following figure show the topographic database used for the hydraulic calculations:

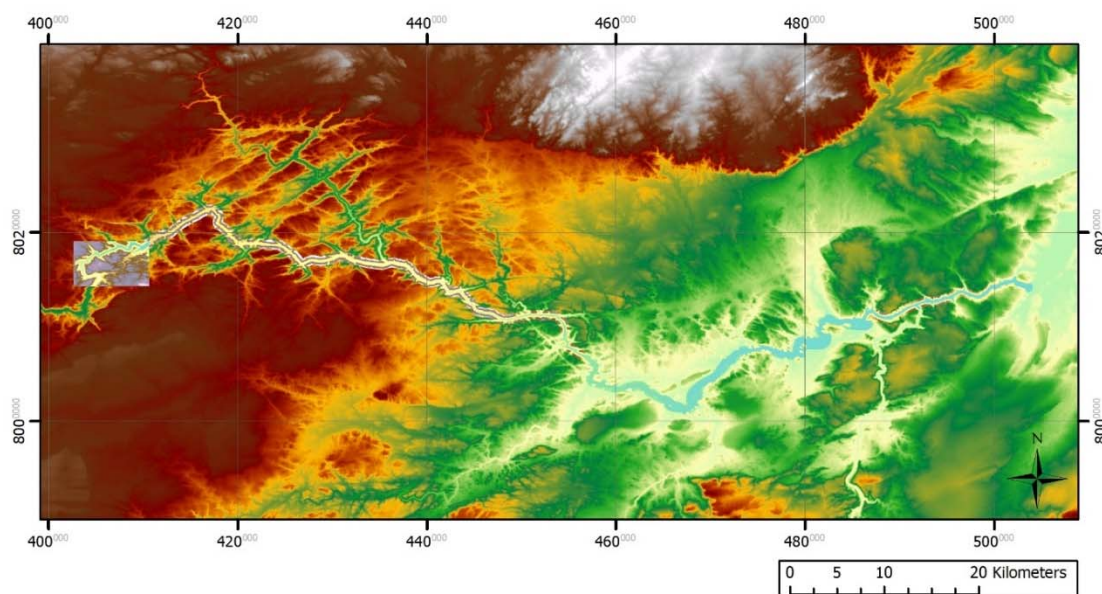

DIGITAL ELEVATION MODEL (WGS 84/UTM zone 35S)

E.8.3 VALLEY MORPHOLOGY AND HYDRAULIC CHARACTERISTICS OF STREAMFLOW

The study of the flood propagation has been analyzed for a river stretch of approximately 120 km length, along the Zambezi river, from the Batoka dam to the Lake Kariba

Downstream of the dam, the river valley is particularly engraved, with both side of the valley very steep. The entire river presents a pronounced slope, in particular the river longitudinal slope can be summarized as follows:

- 0.35 % from 0 to about 8.2 km ds of the dam;
- 0.17 % from 8.2 km to about 35 km ds of the dam;
- 0.1 % from 35 km to about 76 km ds of the dam;
- 0.006 % from 76 km to about 120 km ds of the dam.

E.8.4 FLOOD ROUTING MODEL - HEC RAS version 5.05 (2D)

Dam Break modelling consists in:

- Prediction of the outflow hydrograph at the dam due dam breach;
- Routing of hydrograph through downstream valley in order to obtain the maximum water level and discharge, along with the time of travel at different locations of the river downstream of the dam.

The HEC-RAS program, developed by the US Army Corps of Engineers (USACE) was used for dynamic flood routing and dam safety analysis. The HECRAS software is based upon a highly optimized version of the National Weather Service (NWS) 1988 dam-break flood forecasting program DAMBREAK.

HEC-RAS is used to hydraulically route the flood through the river and downstream valley.

The two dimensional (2D) model is considered more suitable than the one dimensional or quasi two dimensional model to analyze the routing of the flood wave generates due to dam failure.

Indeed, when a flood wave enters an unconfined floodplain, a two dimensional model is appropriate to simulate the behavior of the flow and to simulate the propagation of the wave since floodwater generally presents frequent divergence of flow in the plain.

The governing equation of the model is the two-dimensional flow de Saint Venant's equations, referred also as Shallow Water equations.

The Swallow Water Equations are adopted when:

- The horizontal scale lengths are much larger than the vertical scale lengths ; and
- Vertical pressure gradient is almost hydrostatic.

In case of propagation of the wave in an unconfined floodplain, the flow is shallow enough and since the vertical accelerations can be neglected, then it can be shown that a good approximation to the flow is to

replace all flow variables by their averages in vertical direction. The resulting, depth-averaged, three-dimensional equations of motion then become a two-dimensional representation in the horizontal plane.

In particular, the unsteady differential form of the Mass Conservation (continuity) and Momentum Conservation, considering the hypothesis of the shallow water, recalled above, are shown below:

$$\frac{\partial H}{\partial t} + \frac{\partial(uh)}{\partial x} + \frac{\partial(vh)}{\partial y} + q = 0$$

$$\frac{\partial u}{\partial t} + u \frac{\partial u}{\partial x} + v \frac{\partial u}{\partial y} = -g \frac{\partial H}{\partial x} + v_t \left(\frac{\partial^2 u}{\partial x^2} + \frac{\partial^2 u}{\partial y^2} \right) - c_f u + f v$$

$$\frac{\partial v}{\partial t} + v \frac{\partial v}{\partial x} + u \frac{\partial v}{\partial y} = -g \frac{\partial H}{\partial y} + v_t \left(\frac{\partial^2 v}{\partial x^2} + \frac{\partial^2 v}{\partial y^2} \right) - c_f v + f u$$

Where t is time, H is a water surface elevation, h is the water depth, q is a source or sink term, u and v are the velocity components in the X and Y direction, g is the gravitational acceleration, v_t is the horizontal eddy viscosity coefficient, c_f is the bottom friction coefficient and f is the Coriolis parameter. (Chaudhry, 2008, Brunner, 2016).

The first term in the moment equation represents the local acceleration, the second term is the convective acceleration, and the further terms describe the forcing from gravity, eddy viscosity, bed friction, and Coriolis force. Using the Manning's formula, the friction coefficient c_f can be expressed as following (in the x -direction):

$$c_f = \frac{n^2 g |u|}{R^{4/3}}$$

Where n is Manning's coefficient, g the gravitational constant, u the velocity in the x -direction and R the hydraulic radius.

The HEC RAS solver uses, for the 2D unsteady flow equation, an Implicit Finite Volume algorithm which provides an increment of improved stability and robustness over traditional finite difference and finite element techniques. With this kind of algorithm, Hec-Ras can handle a completely dry 2D element during a sudden rush of water, which is typical in a dam break analysis; furthermore the algorithm can perform subcritical, supercritical and mixed flow regimes.

In order to implement the numerical model the following steps were to:

- develop the geometry and therefore the computational mesh.;
- define the roughness coefficient based on the land cover map;
- evaluate boundary and initial condition.

E.8.5 MODEL GEOMETRY – COMPUTATION MESH

A georeferenced HEC-RAS computation model was prepared, by taking advantage of the HEC-RAS mapper utility.

The model consists in an unstructured computational mesh spreading from the dam toe to the Kariba Lake.

The main river and creek paths were used as break lines in order to align the mesh faces to water courses. In the same way, any kind of barriers to the flow were highlighted and introduced in the construction of the computational mesh by use of break lines.

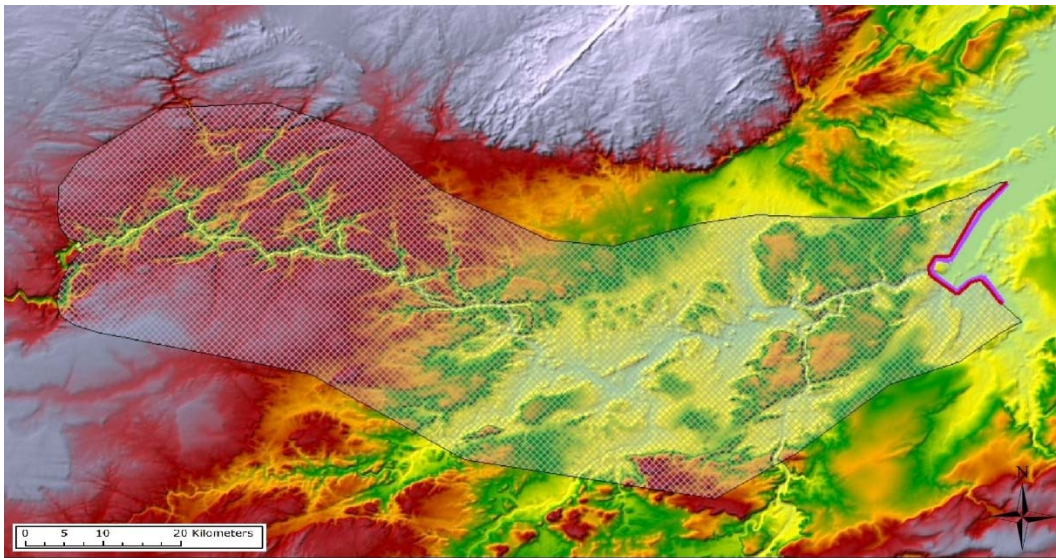

EXTENSION OF THE COMPUTATION DOMAIN

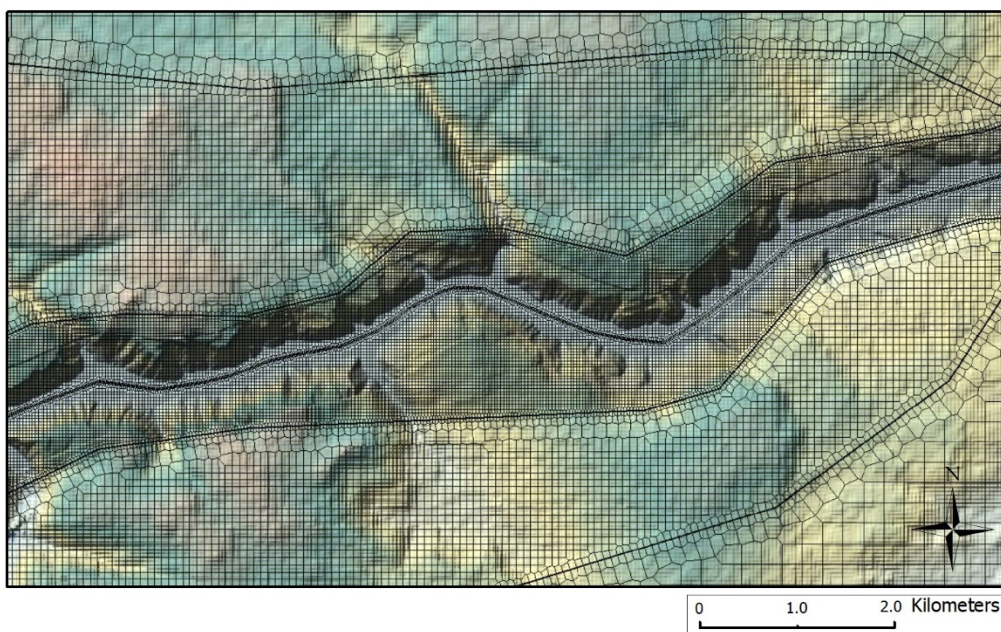

DETAIL OF COMPUTATIONAL MESH

Considering a square geometry of the cells, the main characteristics of the domain geometry for this analysis are listed below:

- Minimum cell size 10x30 m (in correspondence of the river bed)

- Maximum cell size 200x200 m (external of the inundation area)
- Total cell numbers 634'000

The cells' dimensions are smaller where needed, for example along the path of the watercourses, in order to correctly describe the thalweg, or where the slope of the terrain is higher.

The size of the grid cells defines the resolution of the model and model results. For this reason, a sensitivity analysis was carried out in order to define the optimum mesh size to be used for these preliminary simulations. Identifying the optimal mesh size is an important activity for a successful numerical modelling. This is a key parameter since a smaller mesh requires a higher computational running time, on the other hand, a larger mesh might reduce the accuracy and/or the stability of the model

E.8.6 LAND COVER and MANNING'S COEFFICIENTS

The Manning n flow resistance figures for the riverbed and banks, have been determined using the VEN TE CHOW method, as quoted in OPEN CHANNEL HYDRAULICS (1959). In applying the above method, a morphological/vegetation observed on the site survey, has been correlated to the reference table.

Considering that the n value of the flood plain is generally larger than that of the channel, SP has assumed two different value for Manning's coefficient, in particular:

- Major stream (regular section with no boulders or brush) $n = 0.025$;
- Flood plain (scattered brush, heavy weeds) $n = 0.05$

E.8.7 BREACH HYDROGRAPH PREDICTION AND BOUNDARY CONDITIONS

Two boundary conditions were applied, geographically defined by 2 ESRI shape files;

- Upstream condition;
 - Breach hydrograph with a flow peak equal to 803'870 m³/s
- Downstream condition
 - full supply level at Kariba Lake, equal to 488.5 m asl

The inflow condition was applied at the upstream limit of the mesh (in correspondence of the dam toe) and the downstream boundary condition was applied in correspondence of the Kariba Lake.

The upstream condition is a critical point in the dam break analysis. Predicting the outflow hydrograph is strongly related to the prediction the breach characteristics, which include the parameters needed to physically describe the breach (breach depth, breach width, and side slope angles) as well as parameters that define the time required for breach initiation and development.

According the FEMA guideline, for concrete arch dam, the breach widths range from 80 percentage of the entire length of the dam to the entire length of the dam and the breach side slope is assumed to range from

vertical to the slope of the valley wall. The breach formation time for modelling purposes ranges from instantaneous to 0.1 hours (USACE, 1980 and 2007; FERC, 1988; Fread, 2006).

The following imagine illustrates the schematic breach of the concrete arch dam

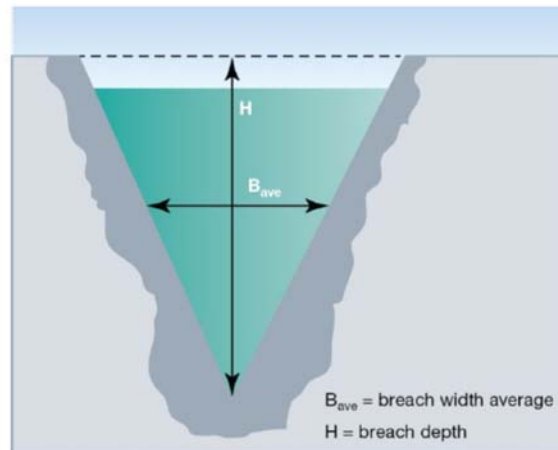

Schematic breach geometry progression of a concrete arch dam

Following the FEMA guidelines, for sake safety, SP has assumed an almost instantaneous removal of entire dam (0.1 h time is the time of fully breach formation).

In this case, the peak breach hydrograph has been computed used the Ritter's formula which represent a simplified of the De Saint Venant equation (USACE, 97)

$$Q_p = B_{ave} * \frac{8}{27} h_0 \sqrt{gh_0}$$

Where:

- Q_p is the peak breach flood;
- B_{ave} is the average width of the breach, which correspond with the average length of the entire dam;
- h_0 is the initial water depth at the dam, which is assumed equal to the dam height;
- g is the acceleration of gravity

The following data has been considered:

- Dam height = 160 m
- B_{ave} = 428 m
- Peak flow = 803'870 m³/s

The beach hydrograph, illustrated in the graph below, has been obtained considering the fully emptying of the reservoir after the failure of the entire dam due the overtopping.

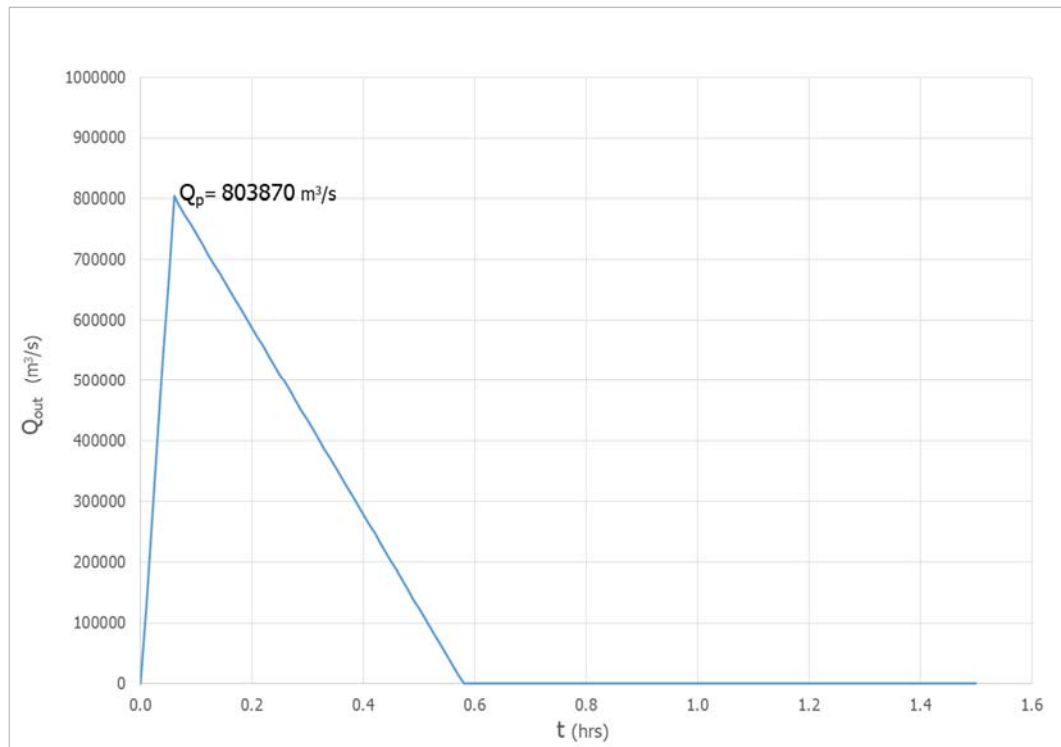

Dam Break hydrograph – Upstream boundary condition

The downstream boundary condition has been set as a constant stage hydrograph equal to 488.5 m asl, corresponded at the Full supply level of the Kariba Lake.

E.8.8 RESULTS

The main results of the hydraulic model for the dam break of the Batoka dam due overtopping re detailed in the following enclosed drawings:

- 346 DBK D SP 001 Inundation Area, General Plan, 300 k
- 346 DBK D SP 002 Inundation Area, Key Map, 300 k
- 346 DBK D SP 003 Inundation area, plan, 100 k, sheet 1 of 4
- 346 DBK D SP 004 Inundation area, plan, 100 k, sheet 2 of 4
- 346 DBK D SP 005 Inundation area, plan, 100 k, sheet 3 of 4
- 346 DBK D SP 006 Inundation area, plan, 100 k, sheet 4 of 4

The graphs below illustrate:

- The discharge's trend in the time for different section downstream of the Batoka dam;
- Inflow to the Kariba Lake;
- The maximum flow at each section with relative arrival time.

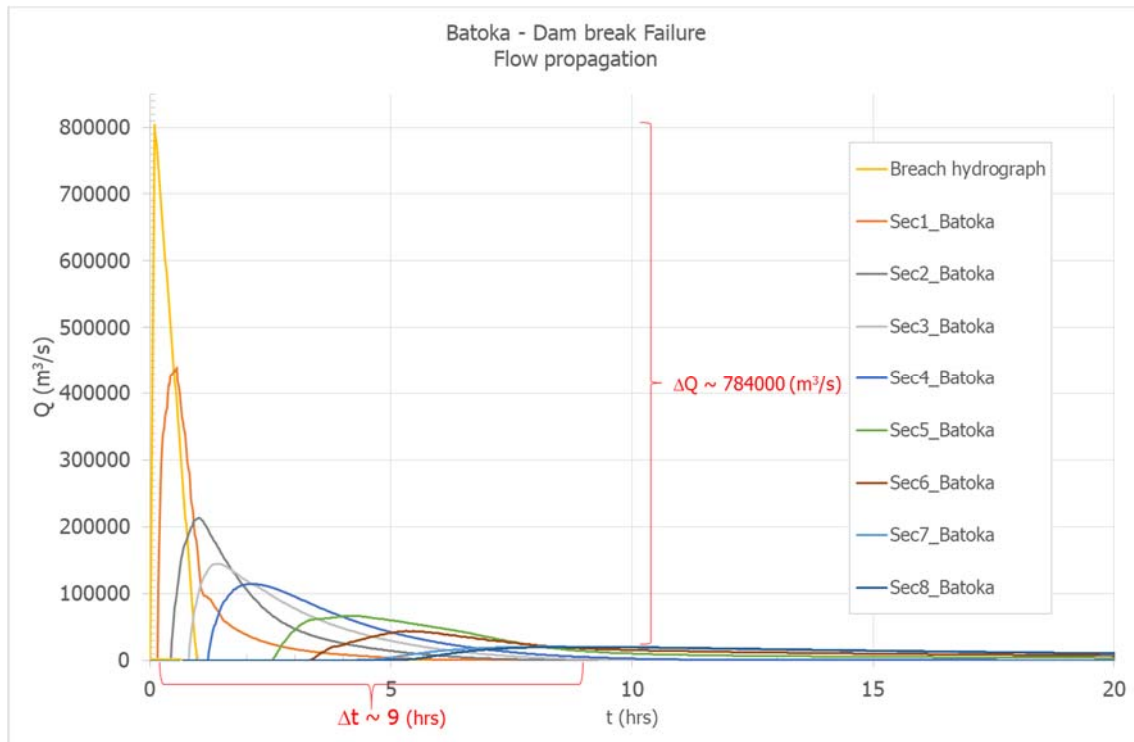

Dam Break hydrograph propagation

As far as the flow propagation is concerned, the peak of flow goes from 803'870 m³/s at the dam toe, to 20'000 m³/s at the last cross section before Kariba reservoir (sec 8), with a total reduction of 784'000 m³/s.

Downstream of Batoka Reservoir, along the Zambezi River, the flow reaches Kariba reservoir, whose capacity is way larger than the one of Batoka reservoir, which is approximately equal to 1'400 Mm³ at dam crest. Indeed, according the data recalled in the Main Report of Sinohydro (2005), the volume of the Kariba reservoir is approximately:

- 54 Mm³ at 475.5 m asl (corresponding with the minimum reservoir level);
- 64'798 Mm³ at 488.5 m asl (corresponding with the maximum reservoir level);

Being very large than upstream reservoir, Kariba reservoir allows the full attenuation the incoming flood.

The arrival time of the peak, which is the difference in time of the peak at the dam toe and the peak of the flow hydrograph simulated in the last downstream cross section, is about 9 hours.

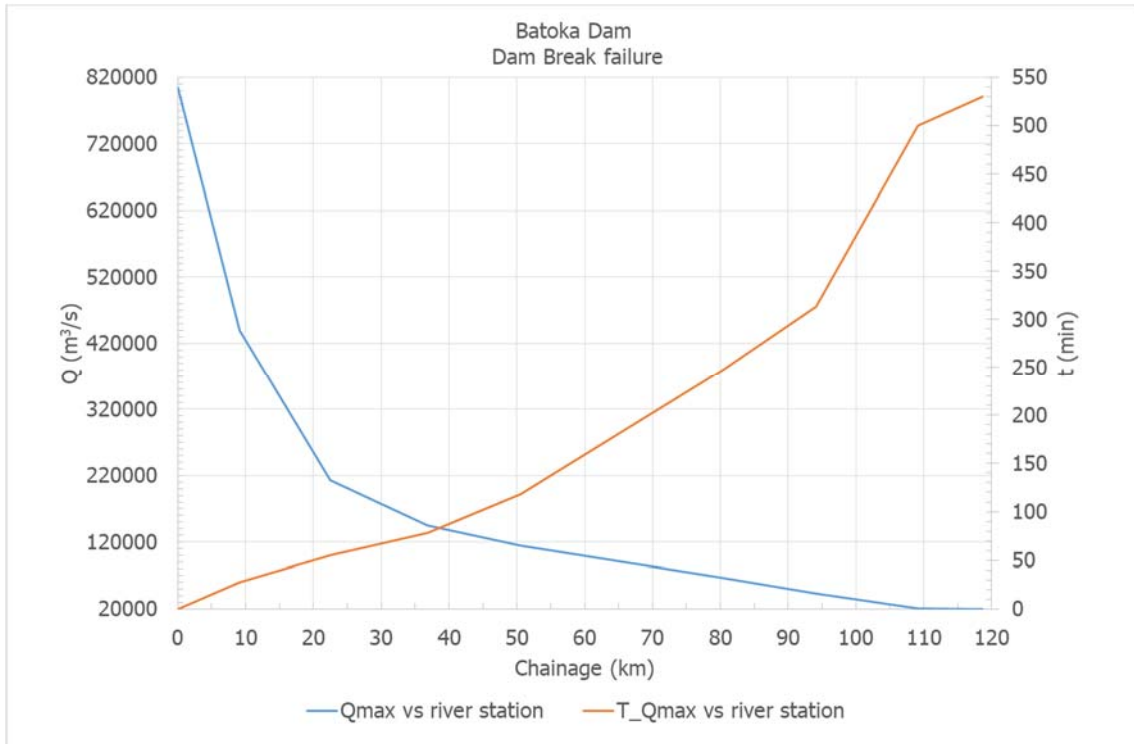

Propagation of the peak flow

Annex D

Water Quality Monitoring Plan

Table1

Water Quality Monitoring Plan

Reservoir and downstream Zambezi River (Figure 1 attached)	Receiving waters downstream of major work sites	
Laboratory (monthly)	Laboratory (monthly)	In-situ (weekly)
<ul style="list-style-type: none"> • pH, • Temperature (in-situ) • Dissolved oxygen • Total Suspended Solids • Electrical conductivity (EC) • Biological Oxygen Demand (BOD) • Chemical Oxygen Demand (COD) • Oil and Grease • Total coliform bacteria • Total dissolved gas (TDG) • Secchi depth and chlorophyll (for lake samples) • Total P, Ammonia-N, nitrate-N, nitrite-N • Total P, orthophosphate • Alkalinity, calcium, magnesium, sodium, potassium, chloride, sulphate • Non volatile metals*** (aluminium, cadmium, chromium, cobalt, copper, iron, lead, manganese, nickel, titanium, zinc, vanadium) • Volatile metals*** (arsenic, mercury) • Pesticides (glyphosate, 2,4-D, aldrin, dieldrin, endrin, heptachlor, PCB, DDT, metoxychlor, endosulfan) 	<ul style="list-style-type: none"> • pH • Biological Oxygen Demand (BOD) • Chemical Oxygen Demand (COD) • Total nitrogen • Total phosphorus • Oil and grease • Total suspended solids • Total coliform bacteria 	<ul style="list-style-type: none"> • pH • Temperature • Dissolved oxygen • ORP • Turbidity • Electrical conductivity
<p>Key: * Based upon ZRA Water Quality Guidelines (1st Edition, 2003) plus additional parameters from ESIA baseline, existing ZRA sampling programmes, etc; ** Based upon IFC wastewater discharge standards (2007); *** Preferably also sample in suspended and bed sediment load (particularly in lake samples).</p>		